

CAMPAIGN BULLETIN

Subject: **Safety Recall 08C4**
Sterling 360 Turbocharger Bracket

Defect Involved

Detroit Diesel Corporation (DDC) has determined that certain Sterling 360 engines, manufactured between April 13, 2007 and February 2, 2008, will require the turbocharger brackets be replaced and in some cases where the turbocharger housing has been affected, the turbocharger will need to be replaced. Certain turbocharger brackets were manufactured with bolt holes improperly aligned with the turbocharger housing mounting boss. This condition may potentially cause thermal fatigue by expansion of the thermal housing mounting boss and cause the turbocharger housing to develop cracks during normal operation.

Replacing the turbocharger brackets will prevent thermal fatigue and eliminate cracking of the turbocharger housing and bring them into compliance with U.S. EPA emissions regulations and prevent customer dissatisfaction.

Engines Involved

A list of engines located in your area of responsibility that require this correction is attached.

The table below gives descriptive information to help identify the affected units:

Model Series	Model Number	Inclusive Mfg. Date (From) (To)
Sterling 360	FE83 D FE84 D FE85 D FG84 D	April 13, 2007 to February 2, 2008

Owner Notification

Detroit Diesel will notify owners of equipment incorporating engines identified with this Recall. A copy of the owner letter that will be used by Detroit Diesel is enclosed.

Safety Recall Bulletin 08C4

Page Two

Owner Notification

Detroit Diesel will notify owners of equipment incorporating engines identified with this Recall. A copy of the owner letter that will be used by Detroit Diesel is enclosed.

Sterling Dealer Modification Responsibility

Authorized Sterling Repair Facilities are to service all engines subject to Recall 08C4. Recall 08C4 is to be performed at no charge to owners on all affected engines under the engine warranty or under the provisions of Recall 08C4.

Please use the appropriate steps, noted below, for indicating that Safety Recall 08C4 has been completed.

Sterling Trucks

- Check the base label (**Form WAR259**) to see if **Safety Recall 08C4** has been completed. The base label is usually located on the passenger-side door about 12 inches (30 cm) below the door latch. If **Safety Recall 08C4** has been completed, no further work is needed. If base label is not located on the passenger-side door, please affix label (**Form WAR259**) 12 inches or 30 cm from the door latch.
- Upon completion of **Safety Recall 08C4**, clean a spot on the base label (**Form WAR259**), write the Safety Recall Number (**08C4**) on a blank, red completion sticker (**Form WAR260**), and attach it to the base label.

Parts Information

NOTE: Parts are available from Freightliner PDC's through Paragon

Part Description	Part Number
Turbocharger Bracket	MBF EX 39

The replacement parts will be available in a kit form. The content of the kit is as below table.

Kit #: EX39

No.	Kit No.	Parts Name	Parts Number	pcs./kit =pcs./unit	Remarks
1	EX39	BRKT, TURBOCHARGER	ME228139	1	
2		SPACER (8 x 20)	MS456738	2	
3		BOLT, FLANGE (8 x 50)	MS146805	2	

Safety Recall Bulletin 08C4

Page Three

In case of crack on VGT housing is found by penetrant inspection:

Part Description	Part Number
Turbocharger Assembly	MBF EX 39A

Kit #: EX39A

#	Parts Name	Parts Number	pcs. /unit	Remarks
1	ME227579	TURBOCHARGER ASSY	1	
2	ME192412	GASKET,AIR OUTLET FITTING	1	Between C/H and coupler
3	ME226787	GASKET,T/C	1	Between T/C and Exh. manifold
4	MH035282	GASKET	2	For by-pass air pipe (Turbine)
5	MF660066	GASKET(16)	1	For by-pass air pipe (Inlet manifold)
6	ME220220	GASKET,COUPLER	1	Between T/C and Exh. coupler
7	ME411885	GASKET,EXH	1	Between Exh. coupler and Fr pipe
8	MH000392	BOLT,WASHER ASSEMBLED (8X12)	13	For insulator of T/C and Exh. manifold
9	MH002331	STUD	8	Between T/C and Exh. manifold Between Exh. manifold and EGR cooler
10	MD050073	NUT(10)	14	For T/C and Exh. coupler installing
11	MH002325	STUD	3	Between T/C and Exh. coupler
12	MH001766	BOLT,FLANGE	1	For Exh. coupler stay installing
13	MH002330	STUD	2	Between Exh. coupler and Fr pipe
14	MH002335	STUD	1	Between Exh. coupler and Fr pipe
15	MH004054	NUT,SELF LOCK FLANGE	7	For Fr pipe and EGR cooler installing
16	MF660063	GASKET(10)	8	For water pipe of electric actuator For oil pipe of T/C
17	MF660064	GASKET(12)	6	For water pipe of T/C
18	ME012494	GASKET,TURBO OIL PIPE	1	For oil return pipe (T/C)
19	MH035015	O-RING(17)	1	For oil return pipe (Crankcase)
20	MF650102	BOLT,EYE(10x20)	1	For oil pipe
21	MF140004	BOLT,FLANGE(6x14)	2	For oil return pipe installing
22	ME221927	GASKET,EGR PIPE	1	Between EGR cooler and EGR pipe (upper)
23	ME225596	GASKET,EGR COOLER	1	Between Exh. manifold and EGR cooler
24	ME226212	GASKET,EGR	1	Between EGR pipe and EGR cooler (lower)
25	MD075165	BOLT,FLANGE	3	For EGR pipe installing (upper)
26	MH001402	BOLT,FLANGE(8X30)	2	For EGR pipe installing (lower)
27	MH063952	JACK	1	Special tool for spreading space between T/C and chassis frame

Corrective Procedure

- Reference the attached **Sterling 360 – Turbocharger Bracket Recall Procedure (Attachment I)**.

Warranty Information

Claim Type:	04
Modification:	08C4
Fault Type:	ZZ
Primary Failed Part:	ME227252
*Labor:	See Table Below for Claimable Labor Hours
Labor Code:	R08C4
Parts Return:	If TURBOCHARGER is REPLACED return to Reman

***Labor Hours**

Order No.	Work Description	Allowable Labor Time	Remark
C10037 10	Replacement of support bracket	0.7 Hr/unit	Standard Cab
C10037 11	Replace a support bracket and Conduct a penetrant inspection	1.7 Hr/unit	
C10037 12	Replace a support bracket and Conduct a penetrant inspection and Replace the VGT assembly	4.5 Hr/unit	

Order No.	Work Description	Allowable Labor Time	Remark
C10037 20	Replacement of support bracket	1.0 Hr/unit	Crew Cab
C10037 21	Replace a support bracket and Conduct a penetrant inspection	2.0 Hr/unit	
C10037 22	Replace a support bracket and Conduct a penetrant inspection and Replace the VGT assembly	6.8 Hr/unit	
C10037 30	Replacement of support bracket	0.5 Hr/unit	Standard Cab In case of concurrent work with C1003310
C10037 40	Replacement of support bracket	0.8 Hr/unit	Crew Cab In case of concurrent work with C1003320

Should you have any additional questions, please contact Detroit Diesel.

DETROIT DIESEL
13400 Outer Drive West
Detroit, Michigan 48239-4001

Replacement procedure

1. Description

Replace VGT Bracket to countermeasure one in order to prevent the crack of turbine housing.

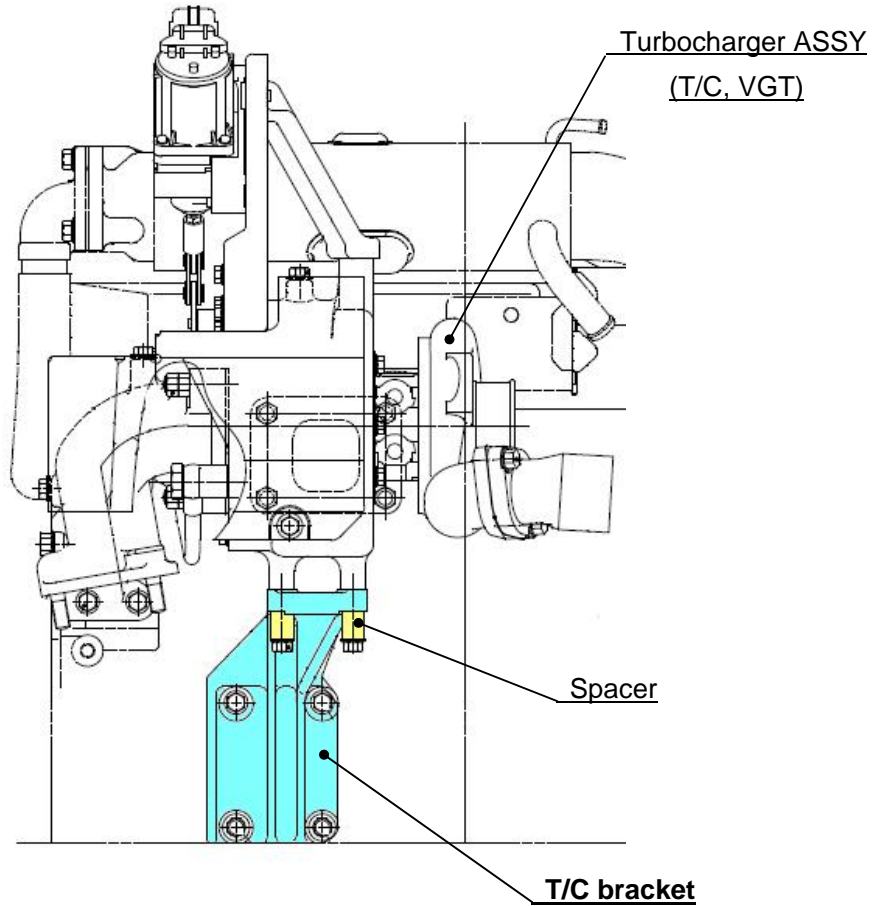

2. Supplied new <Kit No. EX39>

No.	PART NO	PART NAME	Pcs /unit	Remarks
1	ME228139	BRACKET,TURBOCHARGER	1	w/ white identification paint
2	MS456738	SPACER (8x20)	2	
3	MS146805	BOLT,FLANGE (8x50)	2	

3. Replacement procedure for the bracket

* Please refer to Service Manual for detailed procedure and specified tightening torque.

3.1. Preparing for the work

Park a vehicle on flat level place and chock the vehicle to avoid unexpected vehicle roll out.

Note; Don't remove a chock before completing all necessary work.



3.1.a. Standard cab

Tilt up a cab and access to Turbocharger bracket from right side of cab.

3.1.b. Crew cab

Access to the turbocharger bracket from under of cab.

3.2 Remove the turbocharger bracket and spacer

Note Don't break the 4 bolts ( ) which are tighten to crankcase because the bolt is reusable.



3.2.a. *The mileage is less than or equal 18,633 mile (30,000 km) :*

Jump to chapter "3.3"

3.2.b. *The mileage is over 18,633 mile (30,000 km) :*

Conduct a penetrant inspection to confirm existence of crack occurrence around VGT housing boss. If a crack is found, replace VGT with a new one. → Jump to chapter "4".

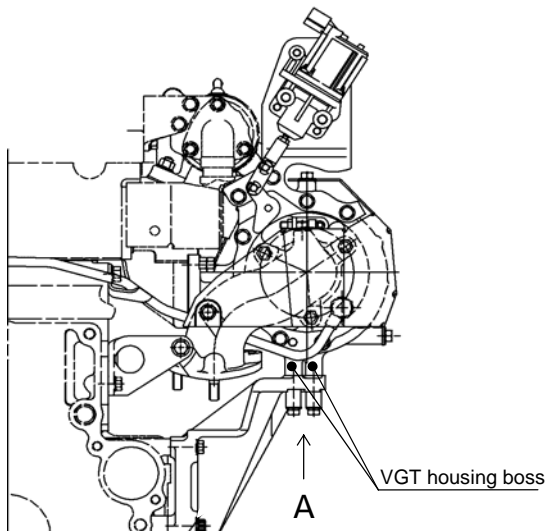

ENG Rear Side View

Confirm existence of crack occurrence around VGT housing (See white

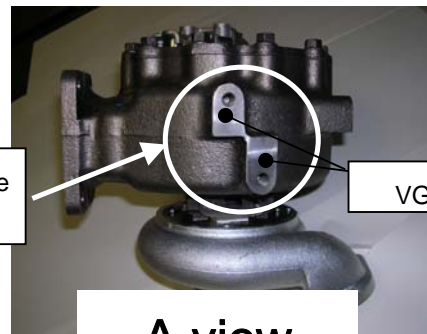

VGT Housing

A view

3.3 Install the countermeasure one.

3.3.1 Tighten the all 6 bolts temporarily and check that there is no space on mounting surface.

3.3.2 Tighten the bolts of crankcase side first (Lower side **1** → Upper side **2**), and then tighten the bolts of the turbocharger side **3** with specified torque.

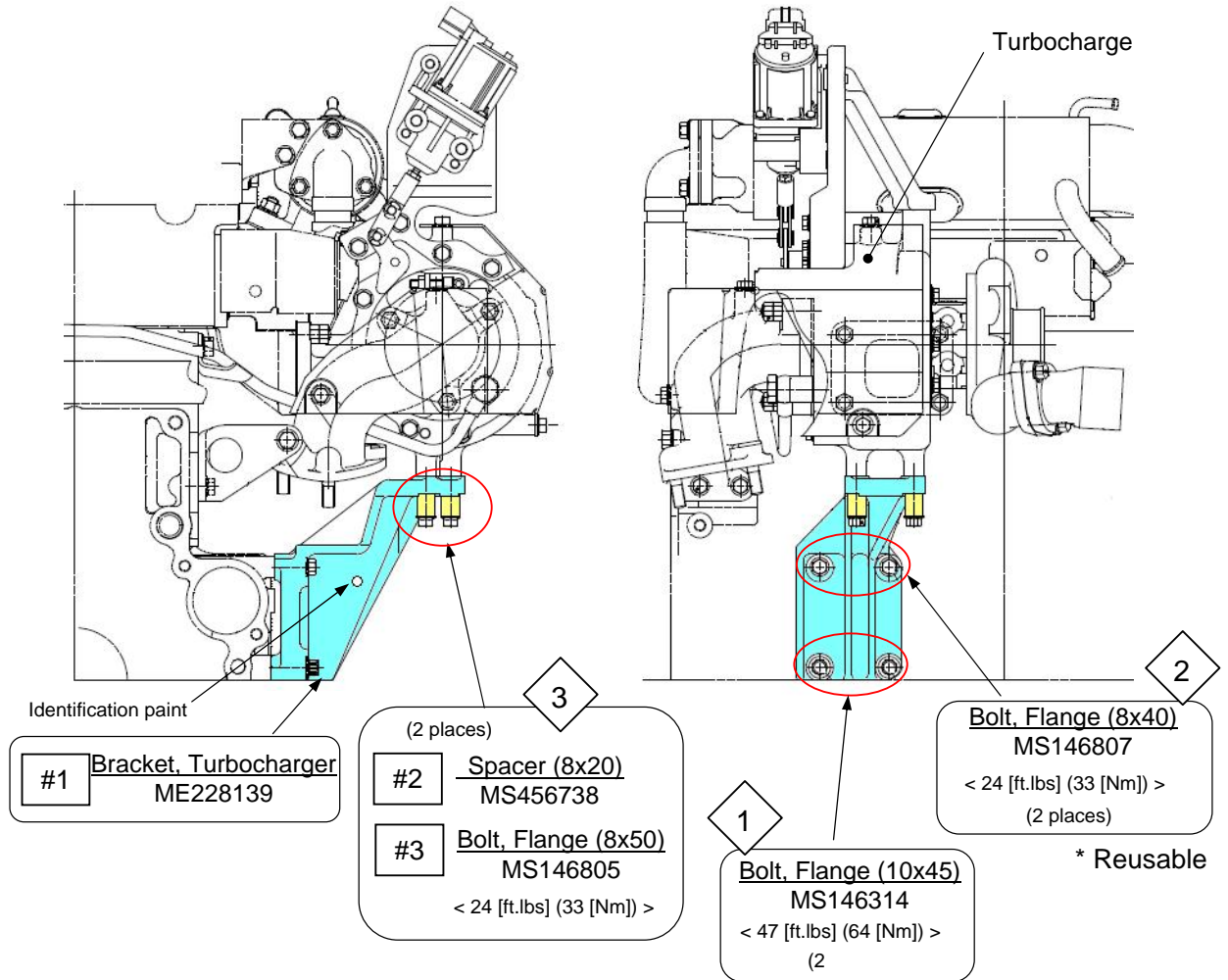

End

A 4. Replacement procedure for turbocharger assembly

4.1 Necessary parts <Kit No. EX39A>

No.	PART NO	PART NAME	Pcs /unit	Remarks
1	ME227579	TURBOCHARGER ASSY	1	
2	ME192412	GASKET,AIR OUTLET FITTING	1	Between C/H and coupler
3	ME226787	GASKET,T/C	1	Between T/C and Exh. manifold
4	MH035282	GASKET	2	For by-pass air pipe (Turbine)
5	MF660066	GASKET(16)	1	For by-pass air pipe (Inlet manifold)
6	ME220220	GASKET,COUPLER	1	Between T/C and Exh. coupler
7	ME411885	GASKET,EXH	1	Between Exh. coupler and Fr pipe
8	MH000392	BOLT,WASHER ASSEMBLED (8X12)	13	For insulator of T/C and Exh. manifold
9	MH002331	STUD	8	Between T/C and Exh. manifold Between Exh. manifold and EGR cooler
10	MD050073	NUT(10)	14	For T/C and Exh. coupler installing
11	MH002325	STUD	3	Between T/C and Exh. coupler
12	MH001766	BOLT,FLANGE	1	For Exh. coupler stay installing
13	MH002330	STUD	2	Between Exh. coupler and Fr pipe
14	MH002335	STUD	1	Between Exh. coupler and Fr pipe
15	MH004054	NUT,SELF LOCK FLANGE	7	For Fr pipe and EGR cooler installing
17	MF660063	GASKET(10)	8	For water pipe of electric actuator For oil pipe of T/C
18	MF660064	GASKET(12)	6	For water pipe of T/C
19	ME012494	GASKET,TURBO OIL PIPE	1	For oil return pipe (T/C)
20	MH035015	O-RING(17)	1	For oil return pipe (Crankcase)
21	MF650102	BOLT,EYE(10x20)	1	For oil pipe
22	MF140004	BOLT,FLANGE(6x14)	2	For oil return pipe installing
23	ME221927	GASKET,EGR PIPE	1	Between EGR cooler and EGR pipe (upper)
24	ME225596	GASKET,EGR COOLER	1	Between Exh. manifold and EGR cooler
25	ME226212	GASKET,EGR	1	Between EGR pipe and EGR cooler (lower)
26	MD075165	BOLT,FLANGE	3	For EGR pipe installing (upper)
27	MH001402	BOLT,FLANGE(8X30)	2	For EGR pipe installing (lower)
28	MH063952	JACK	1	Special tool for spreading space between T/C and chassis frame

4.2 Replacement procedure

* Please refer to Service Manual for detailed procedure and specified tightening torque.

4.2.1. Preparing for the work

Park a vehicle on flat level place and chock the vehicle to avoid unexpected vehicle roll out.

Note; Don't remove a chock before completing all necessary work.

4.2.1.a. Standard cab (Tilt up a cab)

4.2.1.b. Crew cab

4.2.1.b.1. Open the inspection lid under the passenger seat

- 1) Tip the seatback forward
- 2) Fold back the floor mat and release the two clamps.
- 3) Raise the seat cushion and attach the hook to the grip.

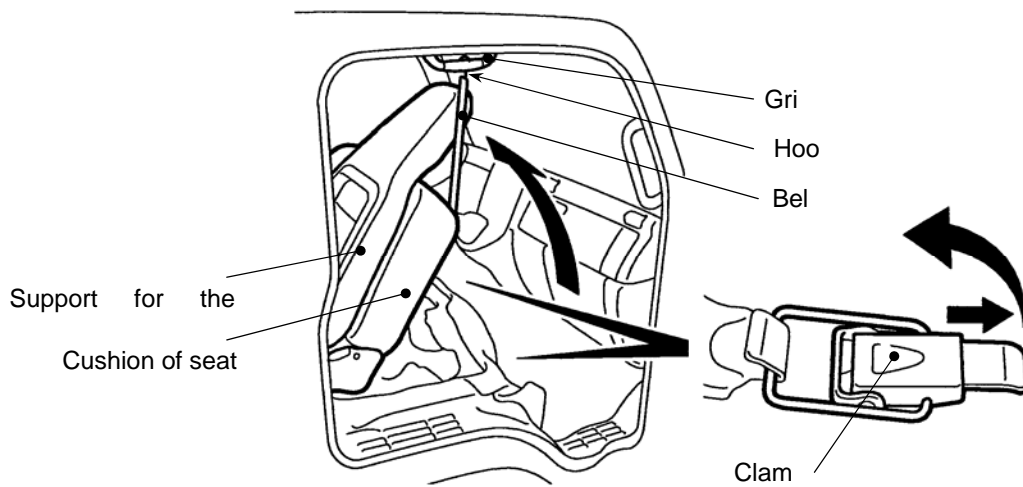

4.2.1.b.2 Open the inspection lid in front of rear seat

- 1) Remove scuff plates on both LH and RH at rear seat.
Note Don't break a clip MC907695 because the clip is reusable.
- 2) Pull a floor mat off floor in order to make an inspection lid available.
- 3) Loosen fixing bolts for inspection lid and open the lid.

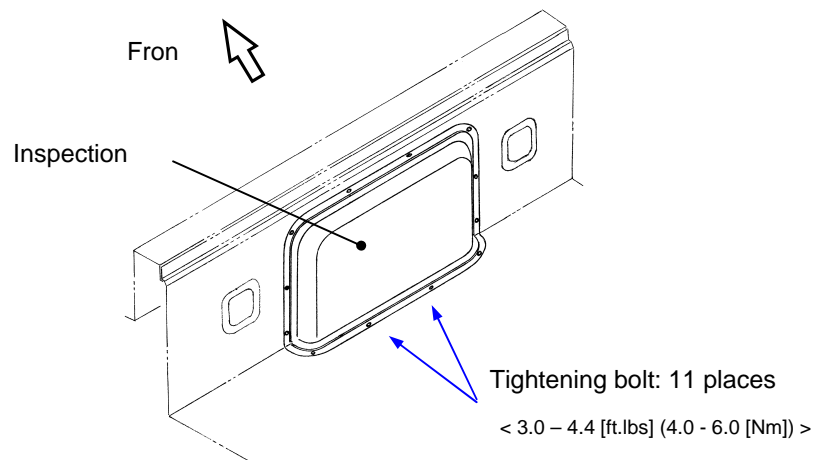

4.2.2 Remove the side cover on right side

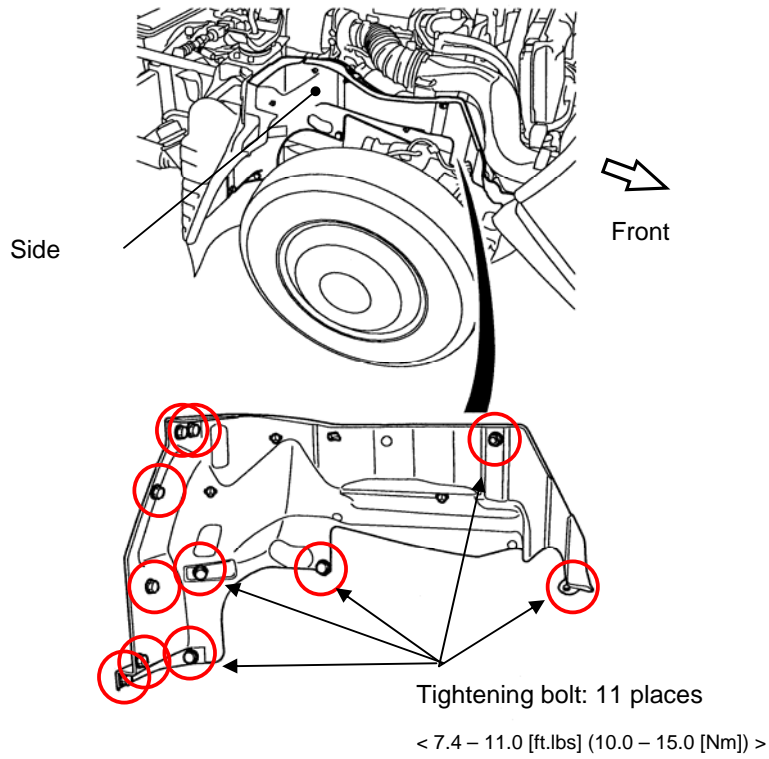

4.2.3 Drain the cooling water

4.2.4 Remove the air duct and air hose

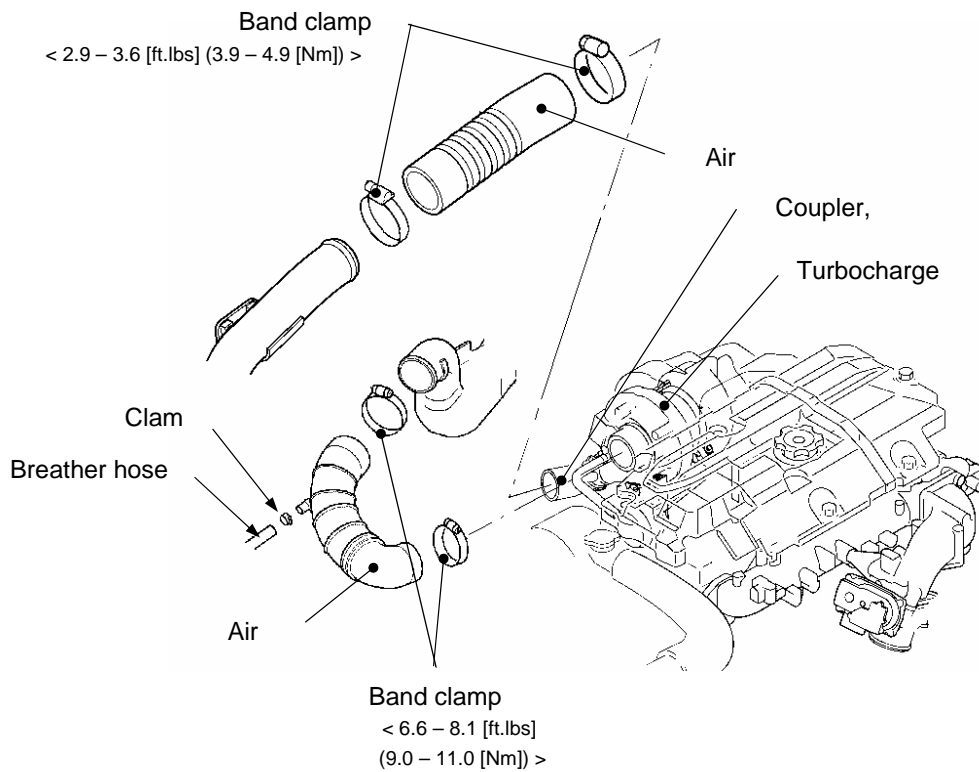

4.3.5 Remove the exhaust coupler

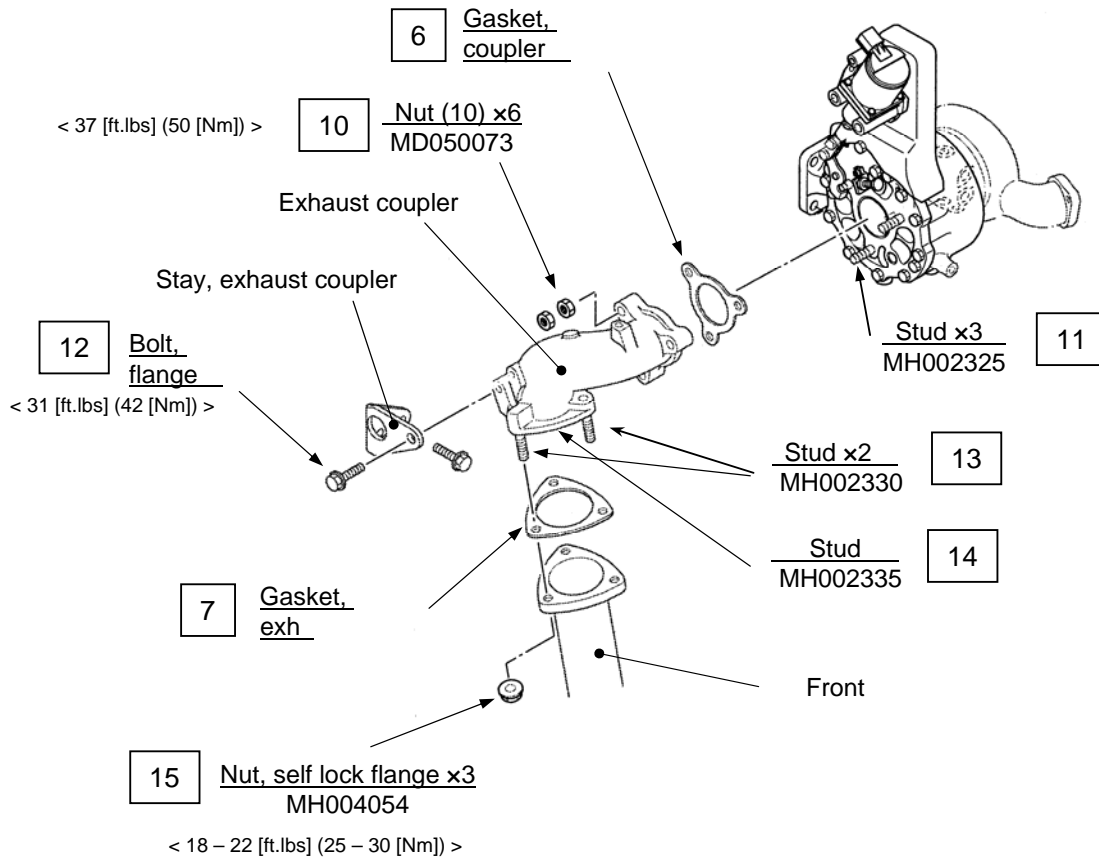

4.2.6 Remove the water pipes and oil pipes connected T/C

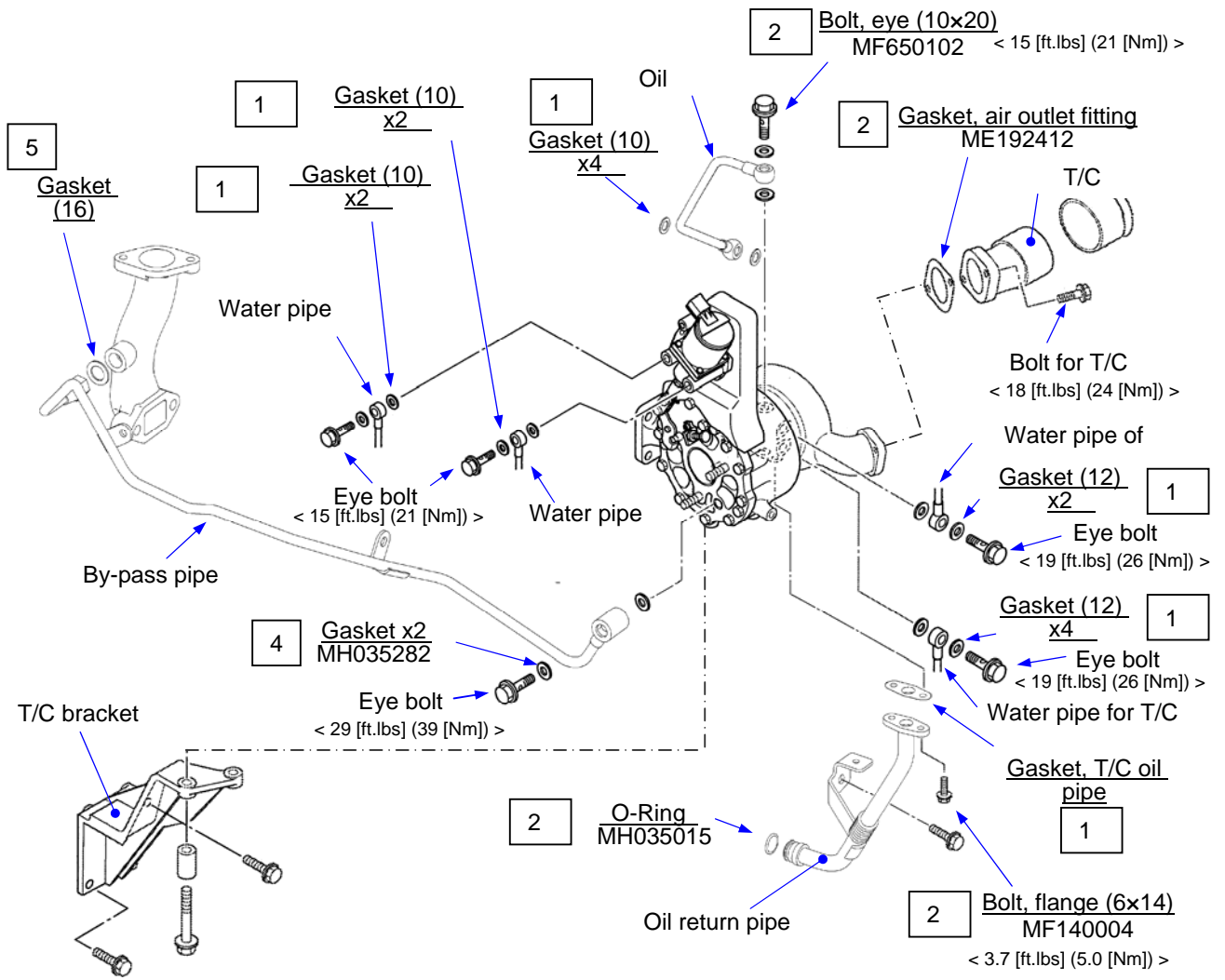

4.2.7 Remove the vacuum pipe and hose

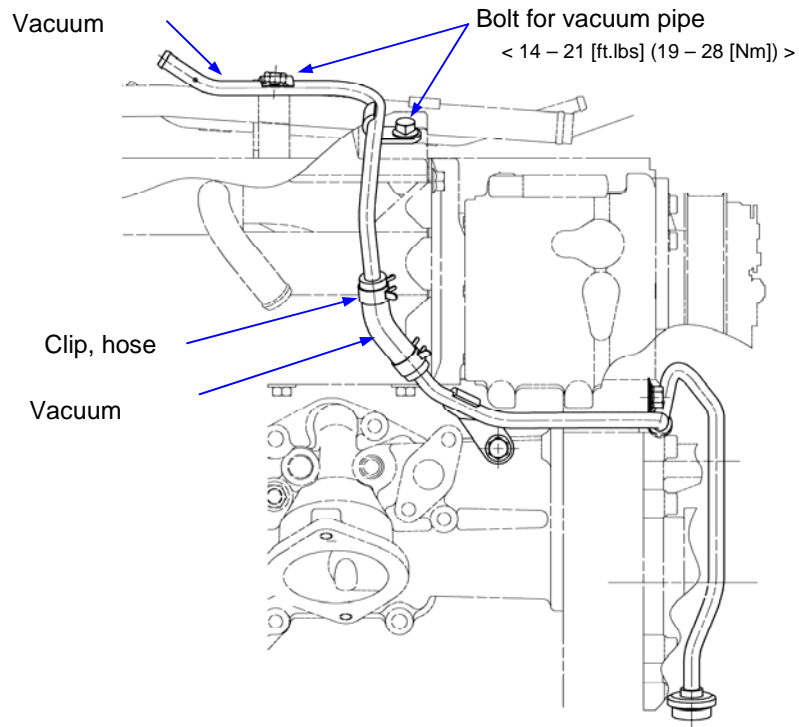

4.2.8 Remove the insulator of T/C and pull out the electric actuator harness

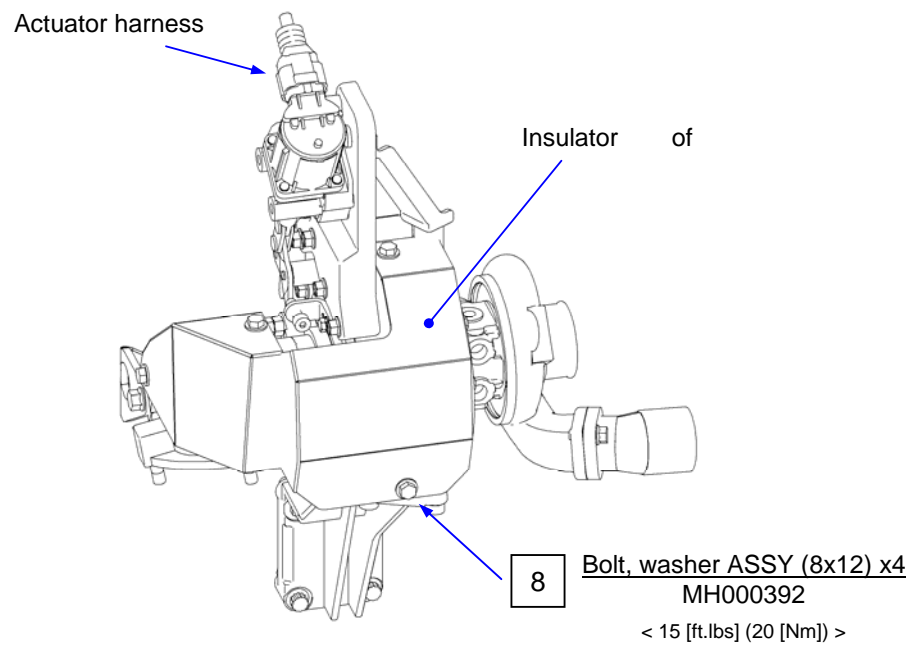

4.2.9 Remove the EGR cooler and the EGR pipe above the T/C

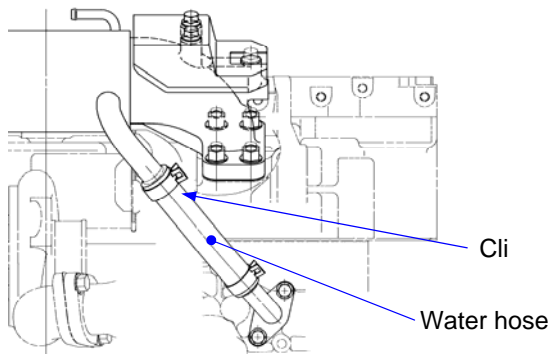
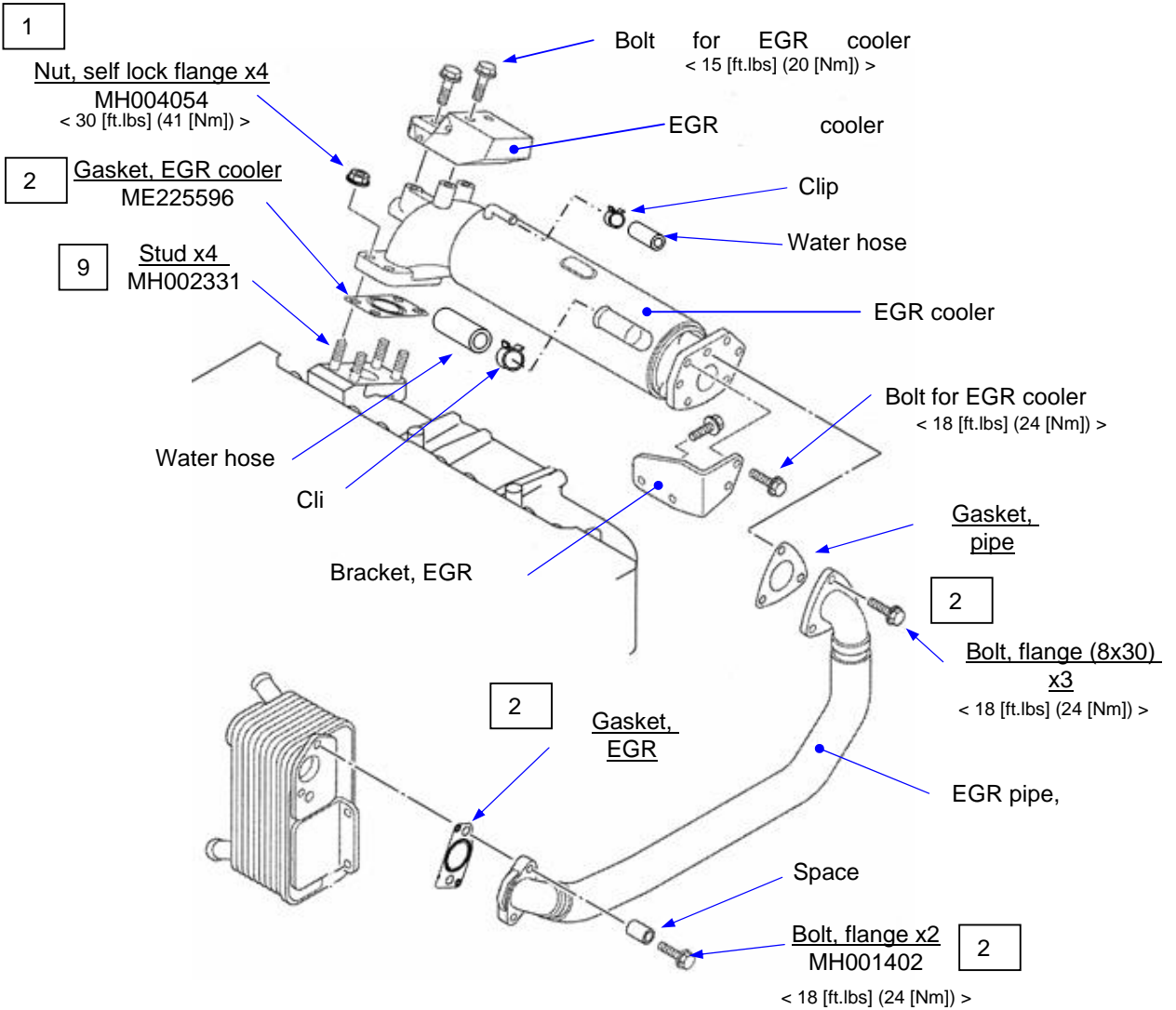

Right side

4.2.10 Remove the exhaust manifold insulator

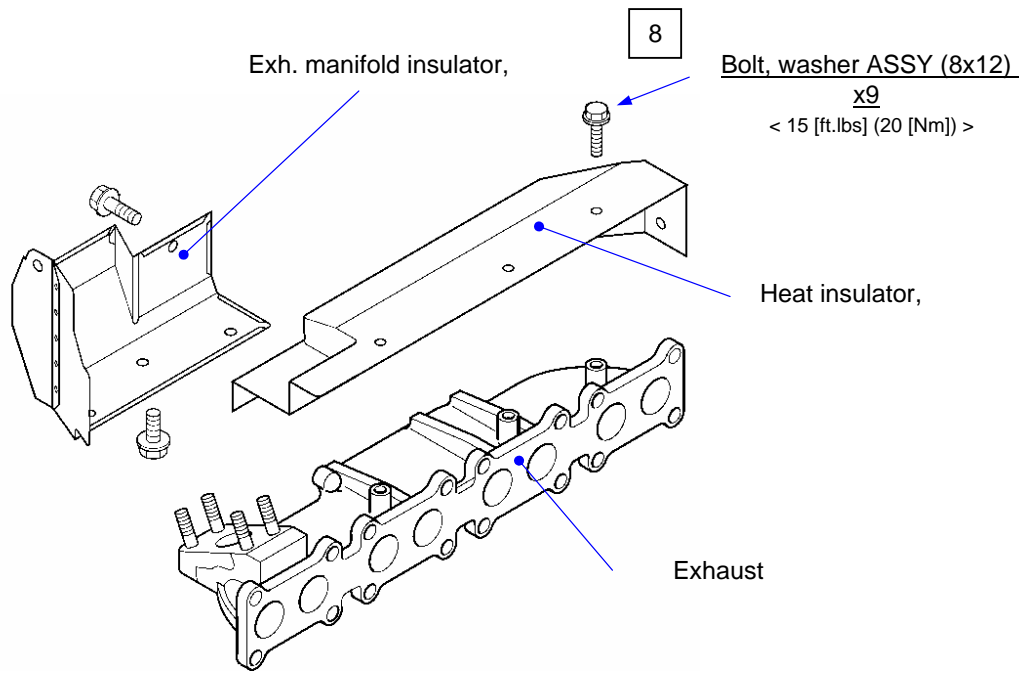

4.2.11 Remove the T/C and replace with countermeasure one

Note; In case that it's difficult to remove the T/C, refer to next page

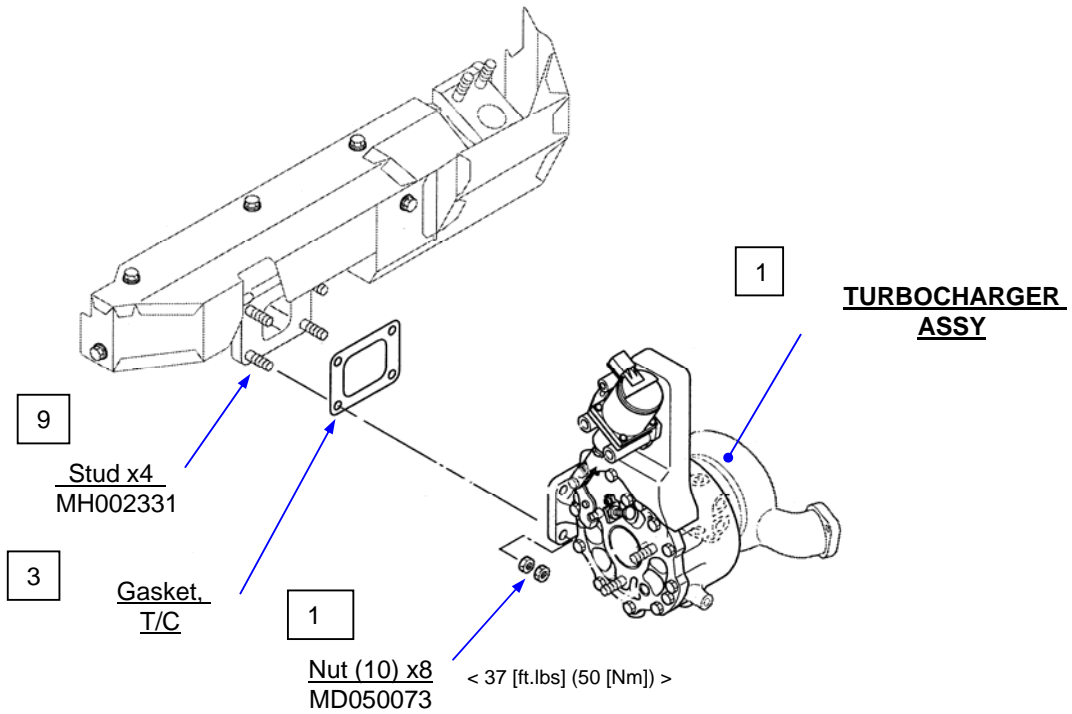

4.3. Install the removed parts in reverse order of above removal procedure

<Epexegeis>

If it is difficult to remove the T/C, use the Jack<MH063952> in order to expand the space between engine and chassis frame

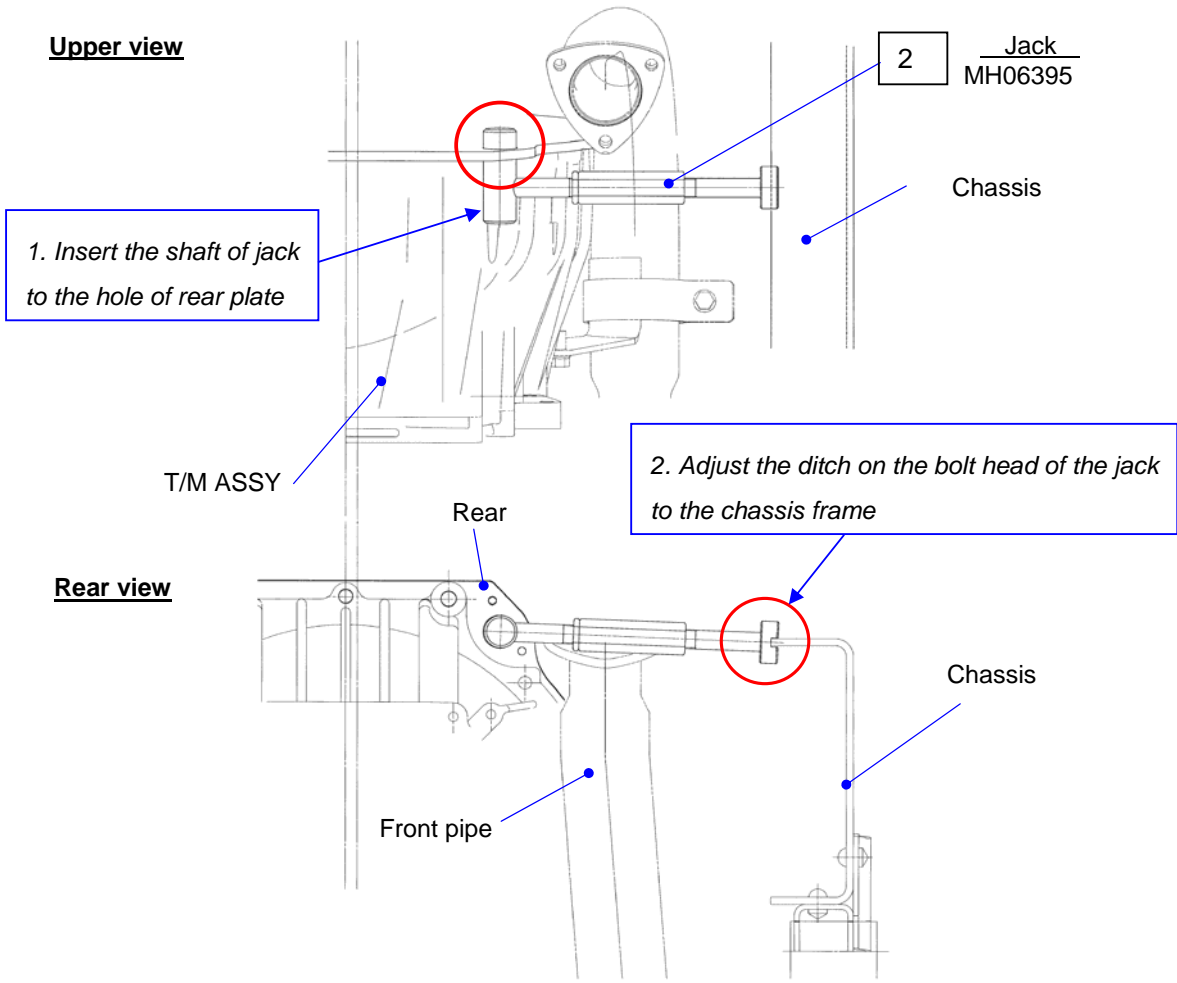

Right side view



3. Rotate the turnbuckle of jack to the direction of the arrow with a spanner