GROUP 01 INDEX

HOW TO READ THE MAINTENANCE SCHEDULE TABLES	01-2
MAINTENANCE SCHEDULE TABLES	01-4
MAINTENANCE OPERATIONS	01-8
LUBRICATION TABLES	01-14
LUBRICATION	01-15

HOW TO READ THE MAINTENANCE SCHEDULE TABLES

Example Table:

Ⓔ: Exhaust emission items.
Ⓖ: Noise control items.

Item (1)	Time of inspection and maintenance (2)								Working procedures (3)	Reference Gr (4)
	Pre-operational checks	New vehicle at 4,000 km/ 2,500 miles	Inspection interval							
			Every 10,000 km/ 6,000 miles	Every 20,000 km/ 12,000 miles	Every 30,000 km/ 18,000 miles	Every 40,000 km/ 24,000 miles	Every 50,000 km/ 30,000 miles	Every 90,000 km/ 54,000 miles		
ENGINE										
Fuel, oil, or coolant leaks from engine	×								Check engine for fuel, oil and coolant leaks.	Gr11, 12 13A, 14
ⒺⒼ Engine conditions	×								Check the engine for smooth starting and quiet running.	Gr11, 13 15, 17, 54
Manifold bolts and nuts torque							×		Check inlet exhaust manifold bolts and nuts for looseness.	Gr15
Ⓔ Check and adjust valve clearance		×					×		Check valve clearance with thickness gauge.	Gr11
Ⓔ Oil filter replacement			Every 10,000 km/6,000 miles or 12 months						Replace oil filters	Gr12

- (1) This column contains the maintenance and inspection items.
- (2) The inspection and service intervals are based on the assumption that the vehicle will be driven approximately 60,000 kilometers (36,000 miles) per year.
Mandatory inspections are indicated by an “x” or by the appropriate period between servicing.
- (3) This column (working procedures) provides a simplified explanation of the operational procedures involved for each inspection or maintenance item.
- (4) This column (Reference group) refers to the “group number” in this manual where detailed procedures can be found.

M E M O

MAINTENANCE SCHEDULE TABLES

Ⓔ: Exhaust emission items.
Ⓖ: Noise control items.

Item	Time of inspection and maintenance								Working procedures	Reference Gr	
	Pre-operational checks	New vehicle at 4,000 km/ 2,500 miles	Inspection interval								
			Every 10,000 km/ 6,000 miles	Every 20,000 km/ 12,000 miles	Every 30,000 km/ 18,000 miles	Every 40,000 km/ 24,000 miles	Every 50,000 km/ 30,000 miles	Every 90,000 km/ 54,000 miles			Every 250,000 km/ 150,000 miles
ENGINE											
Leakage of coolant, fuel and oil	×									Check the underneath of the vehicle for any sign of leakage.	Gr11, 12, 13A, 14
ⒺⒼ Engine conditions	×									Check the engine for smooth starting and quiet running.	Gr11, 13, 15, 17, 54
Manifold bolts and nuts torque								×		Check inlet exhaust manifold bolts and nuts for looseness.	Gr15
Ⓔ Check and adjust valve clearance		×						×		Check valve clearance with feeler gauge.	Gr11
Ⓔ Oil filter replacement			Every 10,000 km/6,000 miles or 12 months							Replace oil filters.	Gr12
Ⓔ Fuel filter replacement			Every 20,000 km/12,000 miles or 12 months							Replace fuel filter.	Gr13A
Ⓔ Fuel line			Every 20,000 km/12,000 miles or 12 months							Inspect the fuel tank, cap and lines for damage causing leakage.	Gr13A
ⒺⒼ Belts tension and damage	×		Every 10,000 km/6,000 miles or 12 months							Inspect belts for crack, wear and tension.	Gr14
Ⓔ Cooling system				×						Check radiator and pressure cap for sealing performance and mounting condition. Inspect hoses for looseness, deterioration, damage causing leakage. Remove dust and foreign matter deposit from radiator and inter-cooler front.	Gr14
Coolant level	×									Check that the coolant level is between the "FULL" and "LOW" marks on the reservoir tank.	Gr14
Coolant replacement			Every 24 months							Replace coolant.	Gr14
Ⓔ Turbocharger rotor play									×	Check turbocharger rotor play.	Gr15
Air cleaner element			Every 5,000 km/3,000 miles							Clean air cleaner element by blowing clean compressed air.	Gr15
ⒺⒼ Air cleaner element replacement						×				Replace air cleaner element.	Gr15
ⒺⒼ Exhaust system				×						Inspect the exhaust system for damage, corrosion and loose connection causing leakage.	Gr15

Item	Time of inspection and maintenance								Working procedures	Reference Gr
	Pre-operational checks	New vehicle at 4,000 km/ 2,500 miles	Inspection interval							
			Every 10,000 km/ 6,000 miles	Every 20,000 km/ 12,000 miles	Every 30,000 km/ 18,000 miles	Every 40,000 km/ 24,000 miles	Every 50,000 km/ 30,000 miles	Every 90,000 km/ 54,000 miles		
⑤ DPF			Every 10,000 km/6,000 miles or 12 months						Check DPF for blocking.	Gr15
			First 185,000 km/110,000 miles thereafter every 105,000 km/65,000 miles						DPF ash cleaning	
POWER TRAIN										
Clutch pedal play	×								Check the clutch pedal for play.	Gr21
Clutch pedal and clutch disc wear			×						Check the pedal for free play. Check clutch disc wear.	Gr21
Range selector lever	×		Every 30,000 km/18,000 miles or 6 months						Check the operate performance of range selector lever	Gr23
Propeller shaft flange torque and universal joint looseness		×	×						Check flange yoke bolts for looseness and universal joint for play.	Gr25
Propeller shaft center bearing							×		Check center bearing if trace of grease flowing out is evident. Check center bearing for wear, damage and play.	Gr25
FRONT AND REAR AXLE										
Wheel hub bearing					×				Check wheel hub bearing for play.	Gr26, 27
Wheel hub bearing hub seals replacement					×				When wheel hub bearing grease is replaced, also replace the wheel hub bearing hub seals.	Gr26, 27
Wheel and tire	×		×						Check disc wheel for corrosion, deformation and cracks. Measure inflation pressure with tire gauge. Check tire tread and side wall for cracks and damage. Measure tire tread groove depth to make sure it is deep enough. Check tire tread for uneven wear, stepped wear and other abnormal wear.	See later section.
			×						Rotate all tires.	
Retightening wheel nuts		×	×						Check wheel nuts for looseness. Check at the first 50 to 100 km/30 to 60 miles after changing a wheel.	See later section.
SUSPENSION SYSTEM										
Suspension springs	×								Check for broken springs and tilt of vehicle body toward either side.	Gr33, 34

MAINTENANCE SCHEDULE TABLES

Item	Time of inspection and maintenance									Working procedures	Reference Gr
	Pre-operational checks	New vehicle at 4,000 km/ 2,500 miles	Inspection interval								
			Every 10,000 km/ 6,000 miles	Every 20,000 km/ 12,000 miles	Every 30,000 km/ 18,000 miles	Every 40,000 km/ 24,000 miles	Every 50,000 km/ 30,000 miles	Every 90,000 km/ 54,000 miles	Every 250,000 km/ 150,000 miles		
Retightening U-bolts		×		×						Check U-bolt nuts for looseness. Check at the first 1,000 km/600 miles after removing and retightening U-bolt nuts. Do not reuse the removed nuts.	Gr33, 34
BRAKING SYSTEM											
Service brake pedal	×									Check brake pedal play and stroke.	Gr35A
Brake performance	×									Press the brake pedal and check that the brakes work effectively and evenly on all wheels.	Gr35A
Disc brake pad and disc			×							Check disc brake pad and disc for damage and wear.	Gr35A
Brake lining			×							Check lining for wear through inspection hole.	Gr35A
Brake drum					×					Disassemble and check drum for wear, crack and damage.	
Parking brake lever stroke	×									Check parking brake lever stroke.	Gr36
Looseness, play and damage of brake system parts			×							Inspect brake lines and hoses looseness, play and damage. Inspect wheel cylinder and brake master cylinder for looseness, play and damage.	Gr35A
STEERING SYSTEM											
Steering wheel play	×									Turn steering wheel right and left to measure play at steering wheel rim. Measure while engine is running.	Gr37
Steering wheel operation	×									Check that the steering wheel does not vibrate or pull to one side and that it is not unduly heavy. Also make sure that the steering wheel returns to its neutral position smoothly.	Gr37
Steering system			×							Check steering system for looseness, steering wheel play and operating condition. Inspect for oil leaks, booster and oil pump function.	Gr37
Drag link ball joint dust cover					×					Check the dust cover for wear, cracks and other damage.	Gr37
CAB											
Defroster	×									Make sure that warm air blows properly onto the windshield.	Gr55

Item	Time of inspection and maintenance									Working procedures	Reference Gr
	Pre-operational checks	Inspection interval									
		New vehicle at 4,000 km/ 2,500 miles	Every 10,000 km/ 6,000 miles	Every 20,000 km/ 12,000 miles	Every 30,000 km/ 18,000 miles	Every 40,000 km/ 24,000 miles	Every 50,000 km/ 30,000 miles	Every 90,000 km/ 54,000 miles	Every 250,000 km/ 150,000 miles		
Rearview mirrors	×									Seated in the driver's seat, adjust the angles for clear views of the sides and rear. Make sure the mirrors are clean.	Gr51
License plate and reflector condition	×									Check the license plate and reflectors for loose installation, damage, and dirt.	–
Door locks	×									Push down the lock knob and verify that the door does not open even when the inner handle is operated.	Gr43
Seat belts	×									Confirm that the seat belt buckles function correctly when fastening and unfastening.	Gr52
ELECTRICAL SYSTEM											
Horn operation	×									Press the horn button to check that the horn is working properly.	Gr54
Windshield washer fluid level	×									Confirm that the windshield washer fluid level is above the bottom of the inspection window.	–
Windshield wiper and washer operation	×									Check the washer for proper fluid spray direction and the wipers for normal action.	Gr51, 54
Lighting system	×									Make sure that each lamp lights up or flashes properly. Check lamp lenses for dirt and damage.	Gr54
Gauge, warning/indicator lamp operation	×									Check that gauges, warning lamps and indicators are working properly.	Gr54

MAINTENANCE OPERATIONS

Tire

Service standards: mm {in}

Location	Maintenance item	Standard value	Limit	Remedy
-	Depth of tire tread grooves	-	1.6 {0.063}	Replace

Torque: N·m {lbf·ft}

Mark	Fastener	Torque value	Remarks
-	Wheel nut	490 ± 49 {360 ± 36}	-

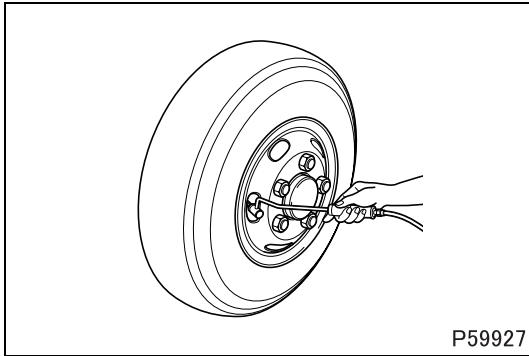

Check inflation pressure

Check air pressure before the vehicle is driven, while the tires are still cool.

Vehicle model	Item	Tire size	Air pressure kPa {psi}
COE 40/45		LT215/85R16-10PR (load range E)	550 {80, 5.5}
COE 50		215/75R17.5 124/123L (load range F)	690 {100, 7.0}

WARNING

Inflate tires to the standard inflation pressure. Tire underinflation or overinflation will damage wheels and tires and could result in a blowout, causing possible personal injury and property damage.

CAUTION

- Always install the valve caps after checking or adjusting air pressure. Unless the valve caps are in place, dirt and dust may stick in the valves and cause a flat tire.

- Make sure the valve cap is securely fitted on each tire.
- It is not necessary to increase tire pressure before high-speed driving.
- On dual wheels, inflate both inner and outer tires to the same pressure.

Check tread depth

- Check all around each tire to make sure the remaining tread is deep enough.
- When the tread wears, slip signs (wear bars) appear across the tire at locations corresponding to the marks.

WARNING

To prevent an injury accident or loss of life, replace worn tires as soon as possible. Worn tires are more susceptible to punctures. They are also more likely to skid and/or hydroplane.

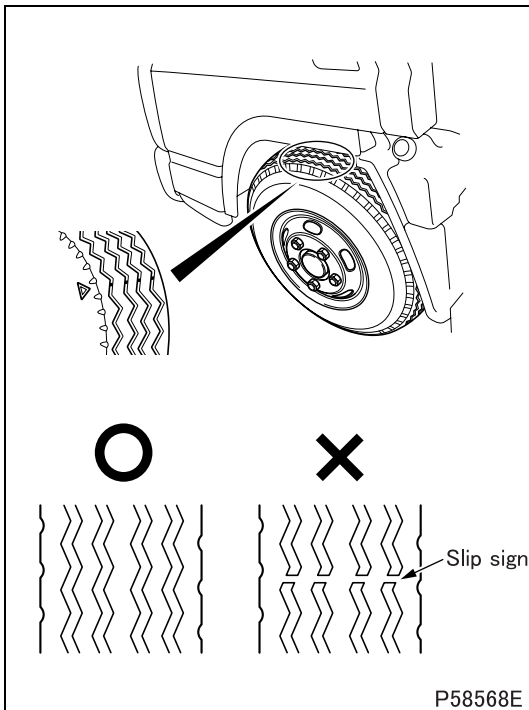

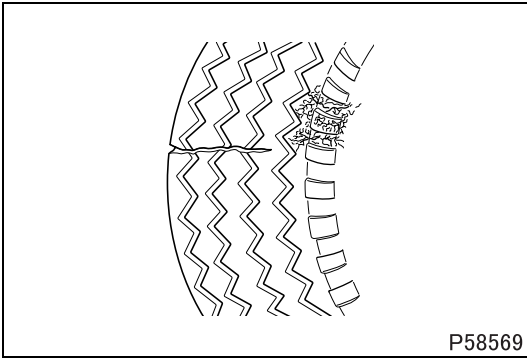

Check for cracks, damage, and objects embedded in the treads

- Check the tread surface and sidewalls of each tire for cracks, damage, and excessive or unusual wear.
- Check for metal pieces, nails, and stones embedded in the tread or caught between the tires (on dual-wheel axles).

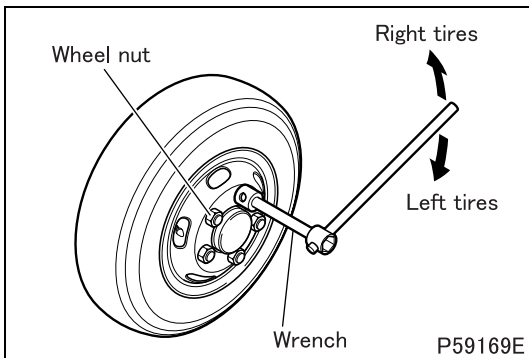

Remove the wheel

- Set the parking brake and chock the front or rear tires, as applicable.
- Position a jack under the front or rear axle jacking point of the vehicle, as applicable. Raise the vehicle high enough to take weight off the wheel, but low enough that the tire still touches the ground.
- Loosen the wheel nuts slightly. The wheel nuts for right tires have right-hand threads “**R**”, and the wheel nuts for left tires have left-hand threads “**L**”.

WARNING

Make certain that the socket is fully seated on the wheel nut. If not, the wrench could slip off the nut and cause a personal injury.

CAUTION

At this time, do not loosen the wheel nuts too much. You could damage the threads.

- Raise the vehicle until the tire is just clear of the ground. Remove the wheel nuts, and then remove the wheel and tire assembly.
- When working on dual-wheel axles, remove the outside wheel and tire assembly first. Then lower the vehicle and loosen the nuts on the inside tire. After doing this, raise the vehicle again and remove the wheel and tire assembly.

MAINTENANCE OPERATIONS

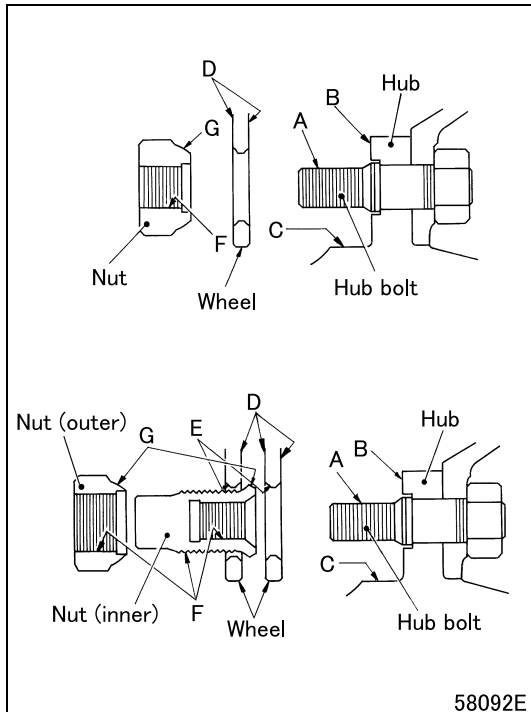

Mounting the wheel

Clean the following areas before mounting the wheel. Dirt or debris in these areas could cause the wheel nuts to become loose during operation.

- A: Hub bolt thread area
- B: Wheel mounting surface of hub
- C: Wheel alignment area of hub
- D: Disc wheel mating surface
- E: Disc wheel nut mounting surface
- F: Wheel nut thread area
- G: Wheel nut spherical area

- Even if only the outside tire is to be changed, do not mount it until the inner wheel nuts have been fastened at the specified torque.
- When installing dual wheels, make sure that the air valve on the inner tire is not lined up with the air valve on the outer tire.

WARNING

If wheel studs or nut threads are damaged, or the disc wheel is cracked or otherwise damaged, replace the wheel. A damaged wheel could work loose and cause an injury accident.

CAUTION

Check hub bolt threads carefully for damage before putting the tire on.

- Mount the wheel on the hub. Install the wheel nuts tight enough to hold the wheel in position.
- If the wheel nut has a spherical end, direct the spherical end toward the wheel. Center the nuts on the wheel studs.
- Lower the vehicle until the tire makes contact with the ground.

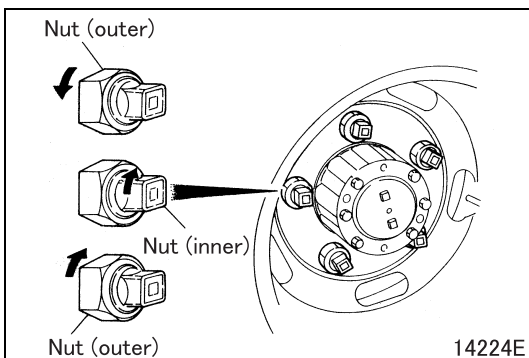
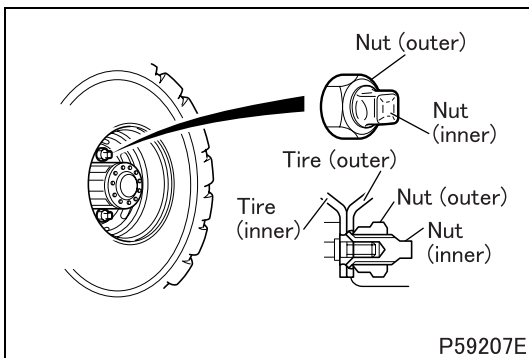
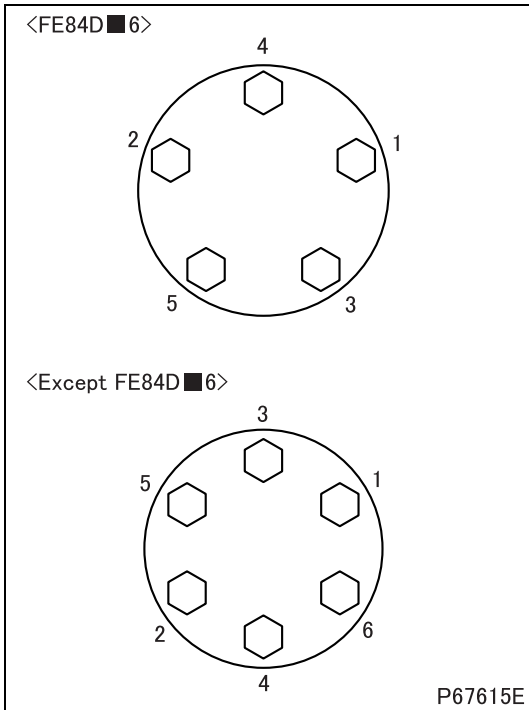

- Tighten the nuts in the order as illustrated, tightening each nut two or three times. To finish, tighten each nut at the specified torque.

WARNING

- Tighten all wheel nuts to the required torque value. When replacing the outer wheel in a dual-wheel set, be sure to tighten the inner wheel nuts before tightening the outer wheel nuts. If the nuts are not tight, the wheel may work loose and cause an injury accident.

CAUTION

- Do not coat the threads of the wheel nuts with grease. If the wheel nuts are over-tightened, they could be damaged.

- On dual rear wheels, mount the outer wheel as described below.
 - When finished mounting the inner wheel and fully tightening the inner wheel nuts, raise the vehicle on the jack again.
 - Mount the outer wheel on the wheel hub, then tighten the wheel nuts to hold the wheel in position.
 - Tighten the wheel nuts in three stages, ending with the final torque shown in the table. Use the tightening sequence shown in the illustration.

Check the wheel nuts

The wheel nuts should be checked for looseness every 10 000 km (6000 miles). All nuts should be tightened to the specified torque value.

- On dual-wheel assemblies, check the wheel nuts as follows:

- (1) Loosen the outer wheel nuts.
- (2) Tighten the inner wheel nuts to the specified torque.
- (3) Tighten the outer wheel nuts to the specified torque.

CAUTION

If the outer wheel nuts are tightened without first being loosened, it might not be possible to tighten them to the specified torque.

MAINTENANCE OPERATIONS

Tire rotation

The amount of wear on a tire depends on its position on the vehicle. To equalize wear and extend life as much as possible, rotate the tires every 10 000 km (6000 miles) in the rotation order shown below:

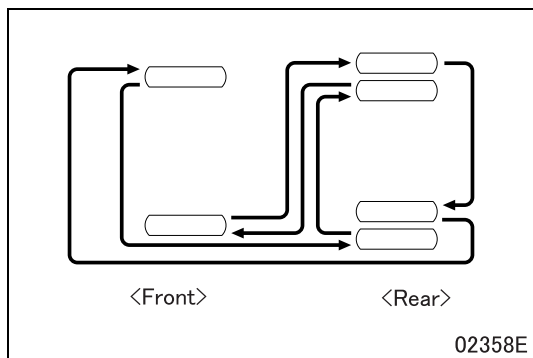

- When the tread pattern for all tires is identical:

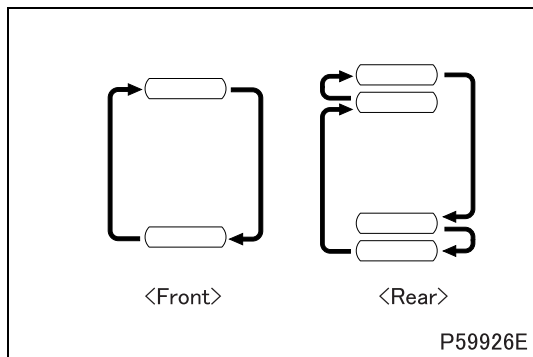

- When the tread patterns are different for the front and rear tires:

NOTE

- *If using different tread patterns on the front and rear wheels, select tires with a ribbed tread for the front wheels and tires with a traction-type tread for the rear wheels.*

WARNING

- **After a wheel has been replaced, the wheel nuts will loosen somewhat as they wear in, creating a potential for an injury accident. Tighten the wheel nuts again after the vehicle has been driven 50 to 100 km (30 to 60 miles).**
 - **Be sure to use tires of the approved type. Mixing bias-ply and radial tires on the same vehicle results in impaired steering and could cause an injury accident or loss of life.**
-

M E M O

LUBRICATION TABLES

Ⓔ: Exhaust emission items.

Items	Time of inspection and maintenance							Lubricant specifications	Reference Gr
	Pre-operational checks	New vehicle at 4 000 km/ 2500 miles	Inspection interval						
			Every 10 000 km/ 6000 miles	Every 20 000 km/ 12,000 miles	Every 30 000 km/ 18,000 miles	Every 40 000 km/ 24,000 miles	Every 50 000 km/ 30,000 miles		
Ⓔ Engine oil level check	×							Engine oil API classification, CD, CD/SF, CE, CE/SF or CF-4 or JASO classification DH-1	Gr12
Ⓔ Engine oil change		×	×					Over 30°C {86°F} SAE 40 40 to -5°C {104 to 23°F} SAE 30 15 to -15°C {59 to 5°F} SAE 20W-20 Over -15°C {5°F} SAE 15W-40 Below 0°C {32°F} SAE 10W-30	
Manual transmission oil level			×					Gear oil API classification GL-3 SAE 80 (temperate climate) GL-3 SAE 90 (warm climate) GL-4 SAE 90 (tropical climate)	Gr22
Manual transmission oil change		×		×				Use engine oil when operating vehicle for long periods at high speeds API classification CC SAE 30 or SAE 40	
Automatic transmission fluid (ATF) level check			×					Mobil ATF3309 manufactured by Exxon Mobil	Gr23
ATF change						×			
Rear axle oil level check			×					Gear oil API classification GL-5 Below 40°C {104°F} SAE 90 Over 40°C {104°F} SAE 140 Use SAE 140 when operating vehicle at high load, such as continuous ascent on slopes and when the outside temperature is 10°C {50°F} or more <Limited-slip differential only> Limited-slip differential oil API classification GL-5 SAE 90	Gr27
Rear axle oil change		×		×					
Hub bearing lubrication					×			Wheel bearing grease [NLGI No. 2 (Li soap)]	Gr26, 27
Brake fluid level check	×							Brake fluid <SAE J1703f or FMVSS No. 116 DOT3>	Gr35A
Brake fluid change							×		
Power steering fluid level check			×					Automatic transmission fluid <DEXRON, DEXRON II or DEXRON III>	Gr37
Power steering fluid change							×		
Lubrication of propeller shaft	Midship bearing						×	Bearing grease [NLGI No. 3 (Li soap)]	Gr25
	Universal joint, slip joint		×					Wheel bearing grease [NLGI No. 2 (Li soap)]	Gr11
Rear suspension spring pin lubrication			×					Chassis grease [NLGI No. 1 (Li soap)]	Gr11.
King pin bearing lubrication			×					Wheel bearing grease [NLGI No. 2 (Li soap)]	Gr11
Door hinge lubrication			×					Chassis grease [NLGI No. 1 (Li soap)]	Gr43
Anchor hook lubrication			×					Chassis grease [NLGI No. 1 (Li soap)]	Gr42

Chassis lubrication

Remove all dust and dirt from the grease fittings. Always use the recommended grease. The areas requiring grease are shown in the following illustration.

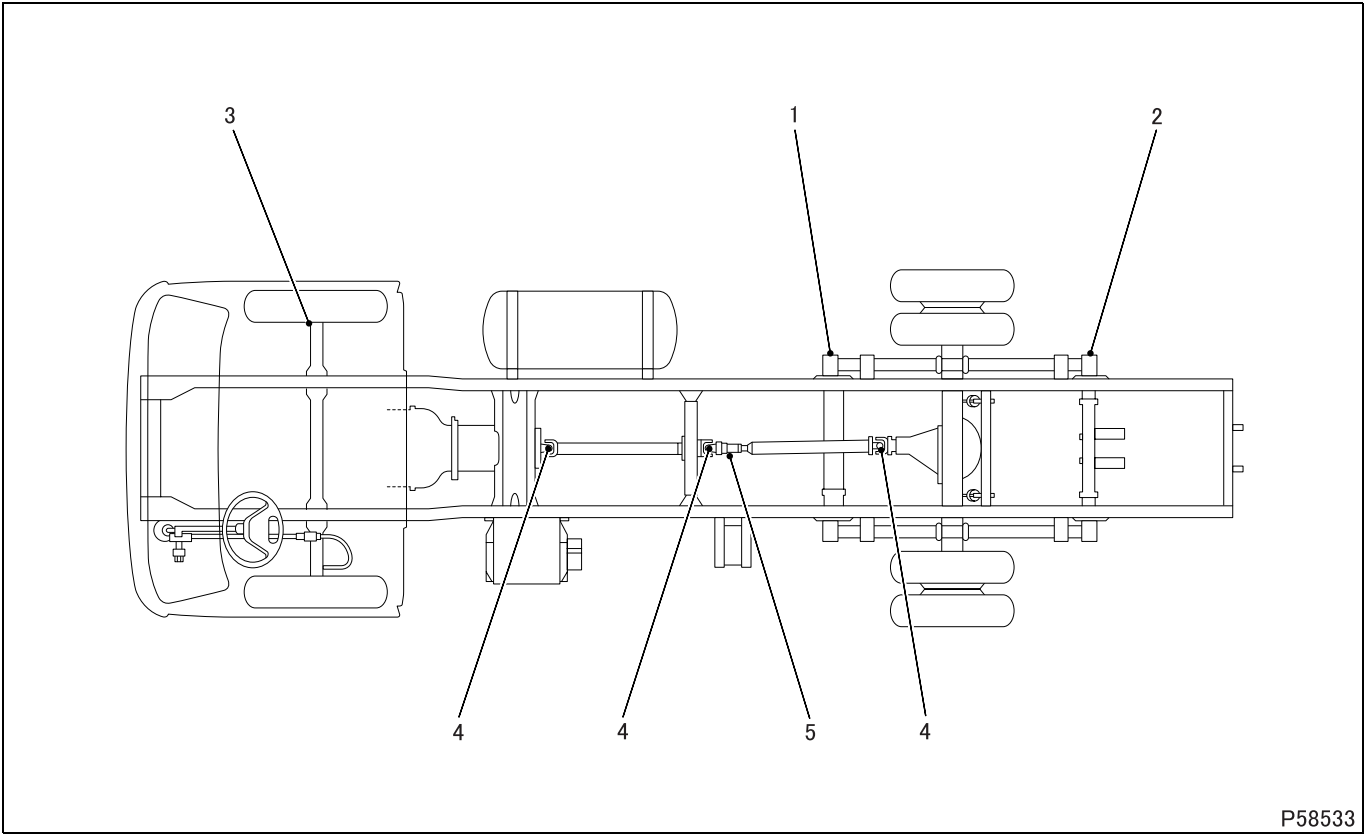

P58533

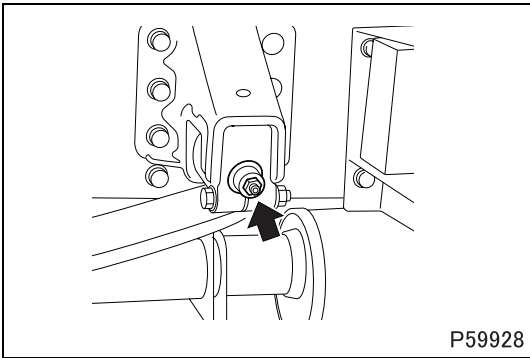

P59928

1. Rear spring pin, forward (2 points total, one on each side)

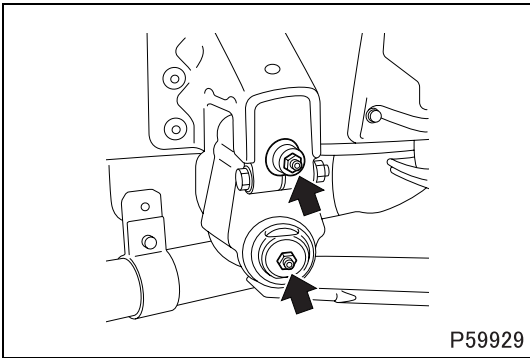

P59929

2. Rear spring pin, aft (4 points total, two on each side)

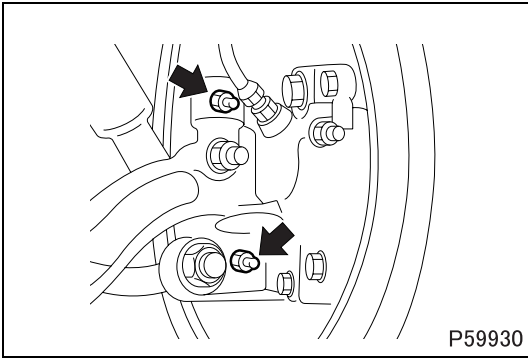

3. King pin bearing (4 points total, two on each side)

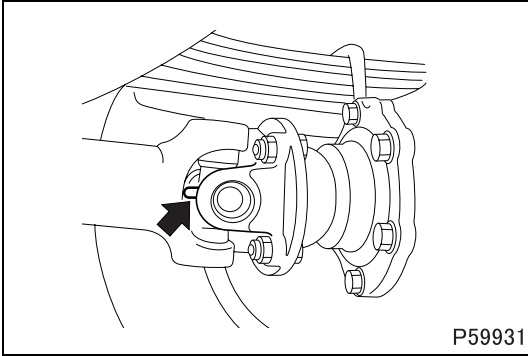

4. Propeller shaft (driveshaft) universal joint

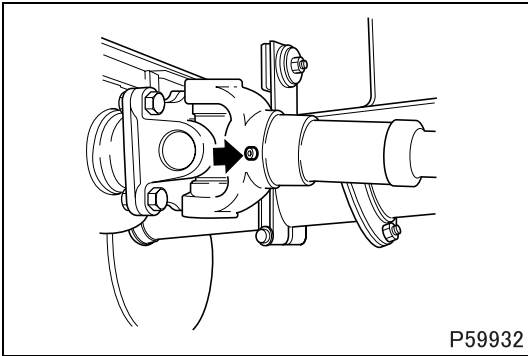

5. Propeller shaft (driveshaft) slip joint