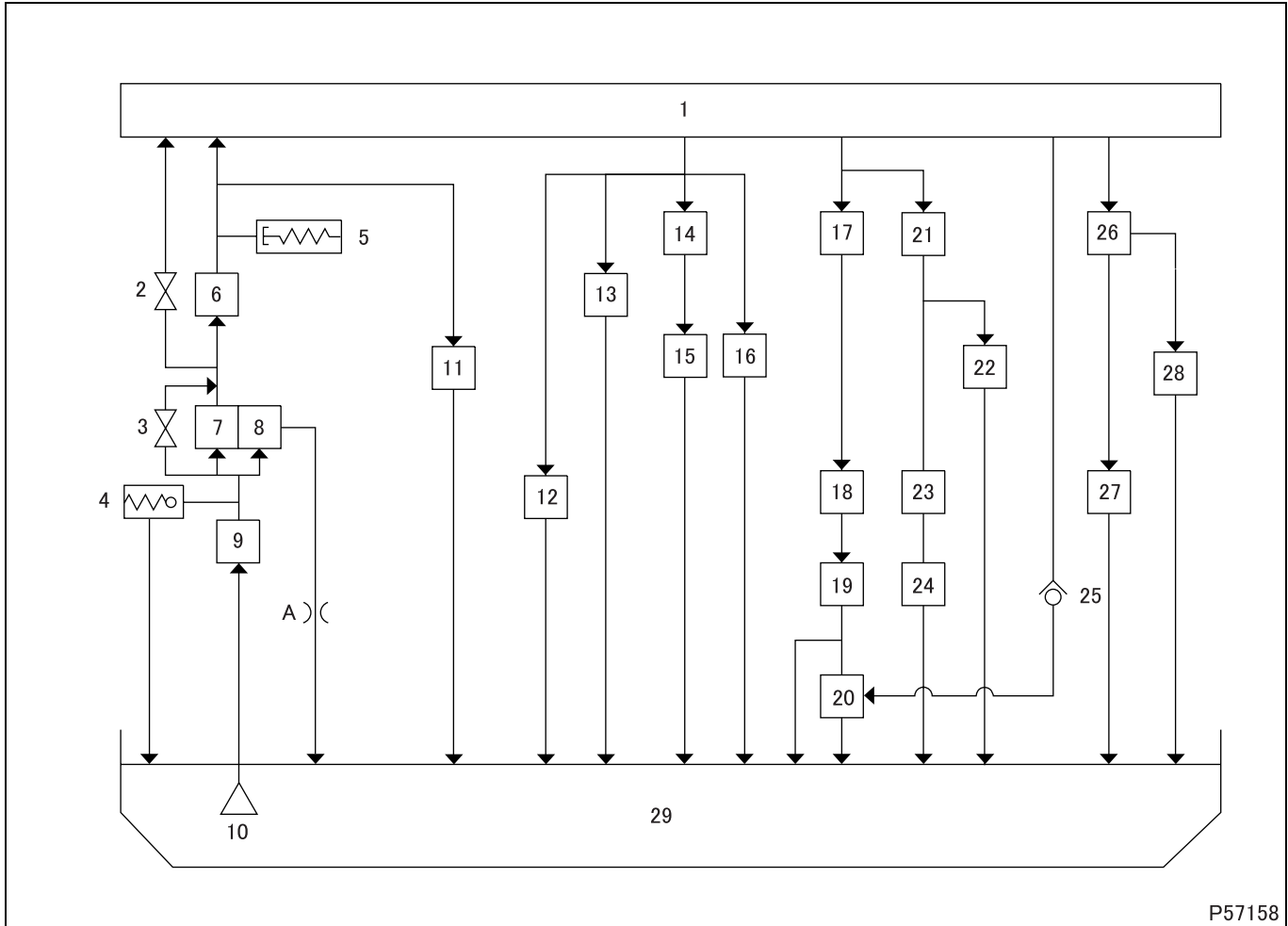

INDEX

SPECIFICATIONS	12-2
STRUCTURE AND OPERATION	
1. Lubrication System	12-3
2. Oil Pump	12-4
3. Oil Cooler.....	12-5
4. Oil Filter	12-6
5. Lubrication of Engine Components	12-7
TROUBLESHOOTING.....	12-10
ON-VEHICLE INSPECTION AND ADJUSTMENT	
1. Oil Filter Replacement.....	12-12
2. Engine Oil Replacement.....	12-14
3. Engine Oil Level Inspection	12-14
4. Oil Pressure Measurement	12-14
OIL PAN, OIL STRAINER AND OIL JETS.....	12-16
OIL PUMP.....	12-18
OIL FILTER.....	12-22
OIL COOLER.....	12-24

SPECIFICATIONS

Item		Specifications	
Method of lubrication		Forced lubrication by oil pump	
Oil filter		Spin-on filter paper type	
Oil cooler		Shell and plate type (multiple-plate type)	
Engine oil	Grade	API classification CD, CD/SF, CE, CE/SF, CF-4 or JASO classification DH-1	
	Quantity L (qts)	Oil pan	Approx. 9
		Oil filter	Approx. 1
Regulator valve opening pressure		kPa {psi, kgf/cm ² } $600 \begin{smallmatrix} +100 \\ 0 \end{smallmatrix} \{87 \begin{smallmatrix} +15 \\ 0 \end{smallmatrix}, 6 \begin{smallmatrix} +1 \\ 0 \end{smallmatrix}\}$	
Bypass valve opening pressure		kPa {psi, kgf/cm ² } $390 \pm 29 \{57 \pm 4.2, 4.0 \pm 0.3\}$	

1. Lubrication System



P57158

- | | |
|------------------------------|-----------------------------------|
| 1 Main oil gallery | 17 Crankshaft main bearing |
| 2 Bypass valve | 18 Connecting rod bearing |
| 3 Bypass valve | 19 Connecting rod bushing |
| 4 Regulator valve | 20 Piston |
| 5 Engine oil pressure switch | 21 Balance shaft bushing RH |
| 6 Oil cooler | 22 Supply pump gear bushing |
| 7 Full-flow filter element | 23 Supply pump idler gear bushing |
| 8 Bypass filter element | 24 Supply pump idler gear shaft |
| 9 Oil pump | 25 Check valve for oil jet |
| 10 Oil strainer | 26 Rocker bushing |
| 11 Turbo charger | 27 Camshaft bushing |
| 12 Oil jet for gear | 28 Rocker roller |
| 13 Vacuum pump | 29 Oil pan |
| 14 Idler bushing | |
| 15 Timing gear | |
| 16 Balance shaft bushing LH | |
- A: Orifice

STRUCTURE AND OPERATION

2. Oil Pump

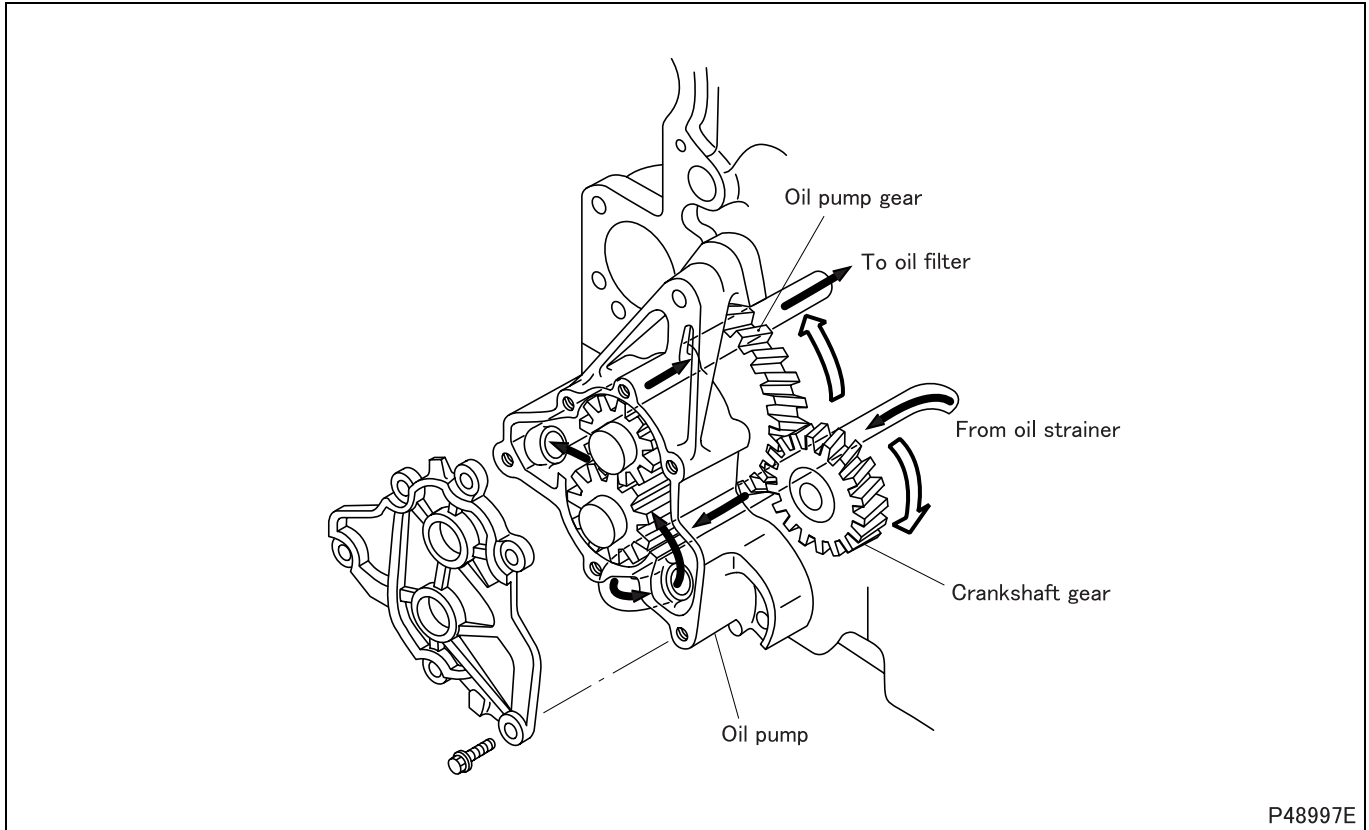

- This engine uses a gear-type oil pump driven by the rotation of the crankshaft transmitted through the engagement of the crankshaft gear and the oil pump gear.

3. Oil Cooler

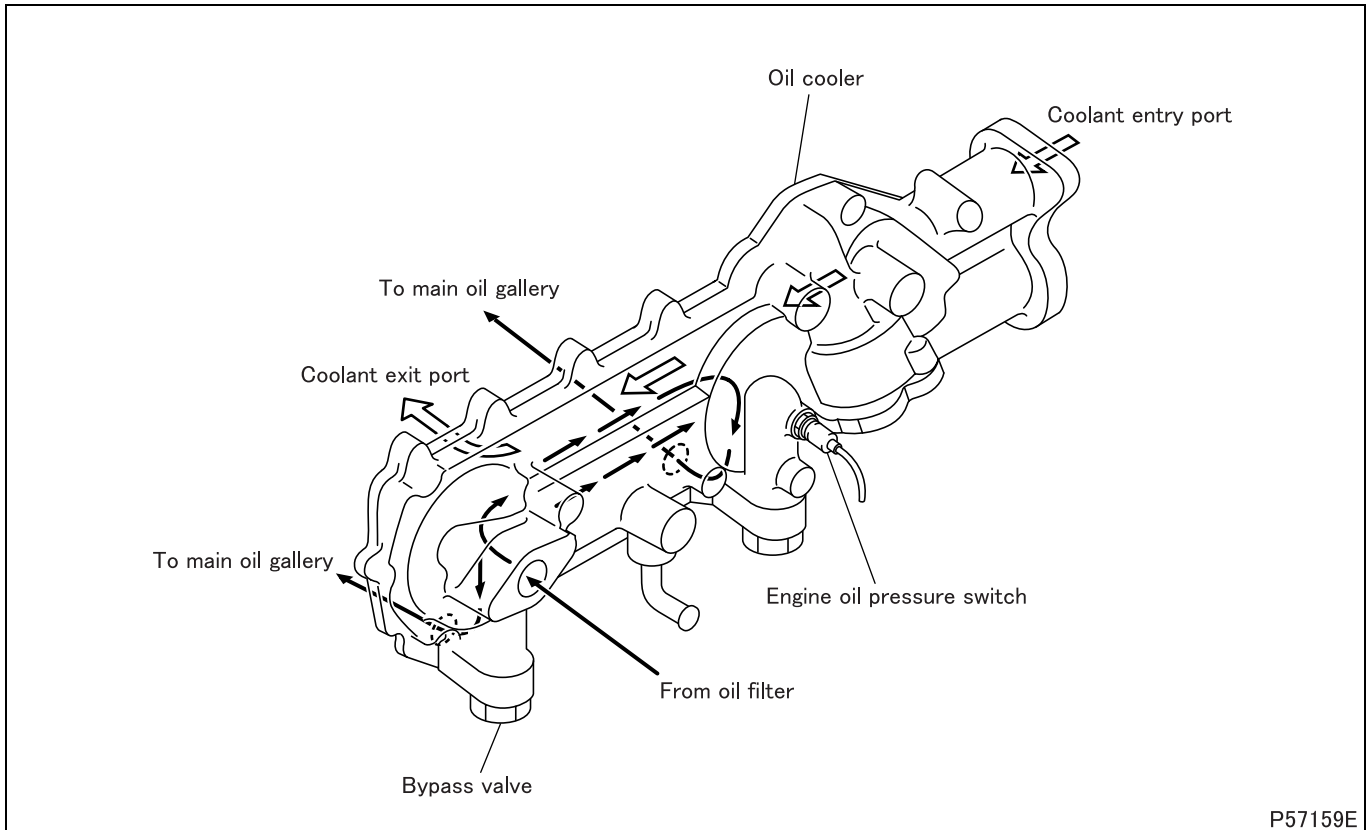

P57159E

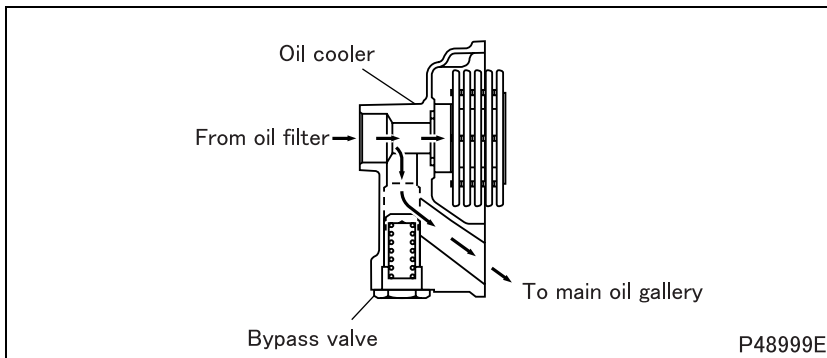

P48999E

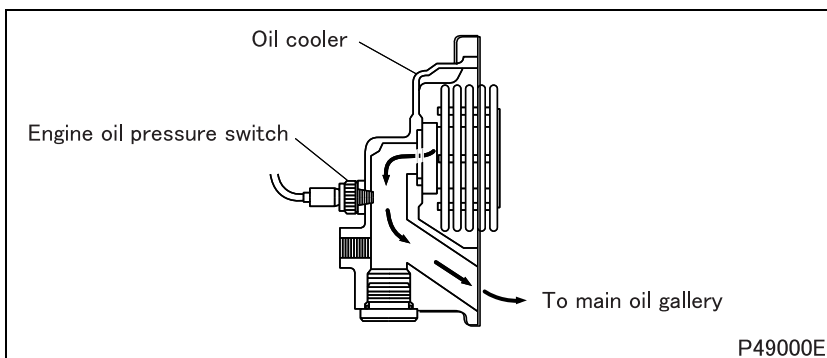

P49000E

3.1 Bypass valve

- When the engine oil is cool and its viscosity is high, or when the oil cooler element becomes clogged and restricts the flow of the engine oil, the bypass valve opens to let the engine oil bypass the oil cooler and flow directly to the main oil gallery.

3.2 Engine oil pressure switch

- When the pressure of the engine oil to the main oil gallery drops below the specified level, an electrical contact inside the engine oil pressure switch closes.
- This causes a warning lamp on the meter cluster to illuminate and notify the operator of the excessive pressure drop.

STRUCTURE AND OPERATION

4. Oil Filter

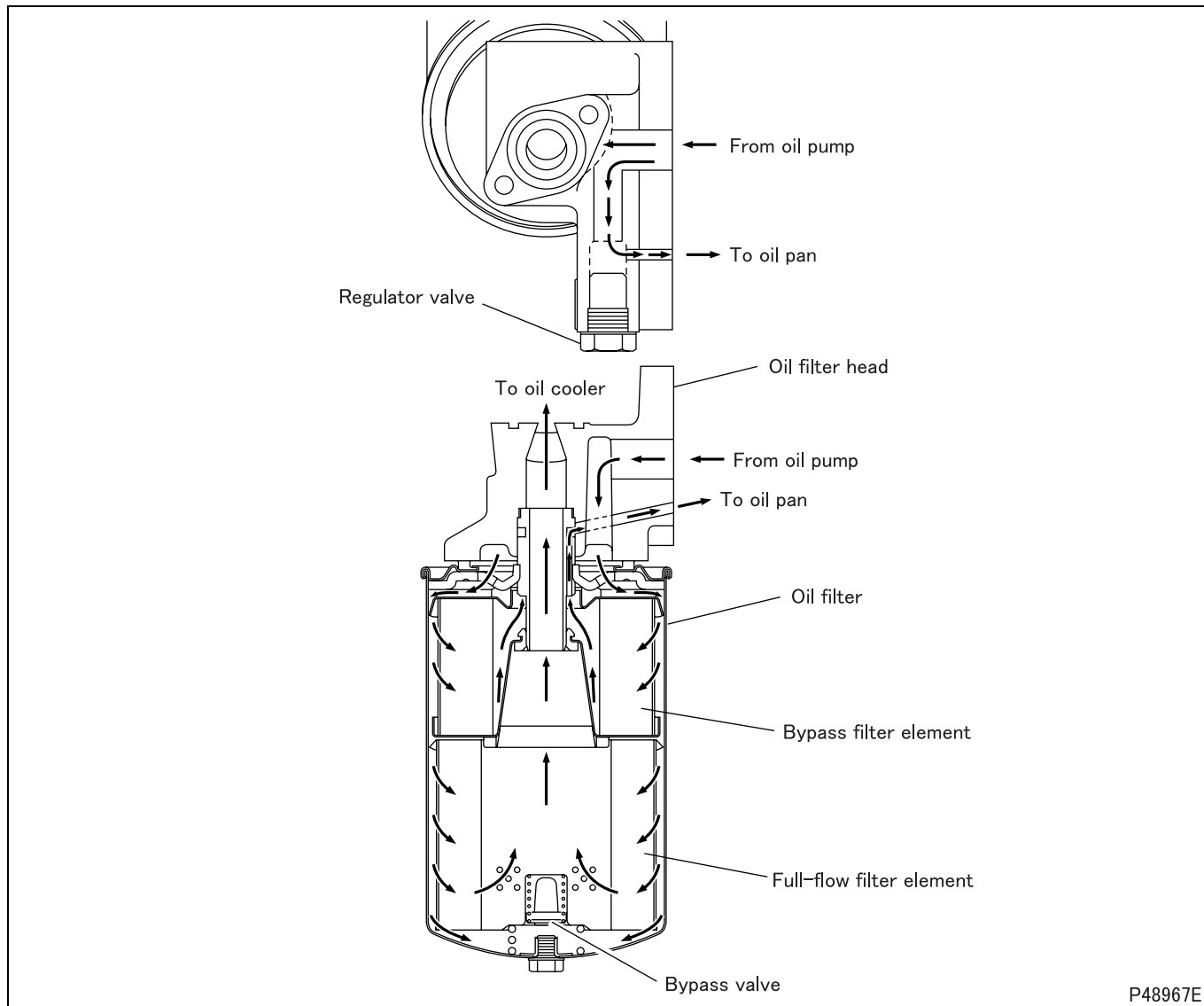

P48967E

- The oil filter used in this engine is a spin-on, paper-filter type that incorporates both a bypass filter and a full-flow filter.
- A bypass valve is installed in the lower part of the oil filter. When the filter elements are clogged, this valve opens to let the engine oil bypass the filter elements and flow directly to the oil cooler, thereby preventing seizures in the engine.
- A regulator valve is installed on the oil filter head. When the oil pressure in the main oil gallery exceeds the specified level, the regulator valve opens to adjust the oil pressure by returning part of the engine oil to the oil pan.

5. Lubrication of Engine Components

- The engine oil in the main oil gallery lubricates the engine components in the following ways.

5.1 Main bearing and connecting rod bearing

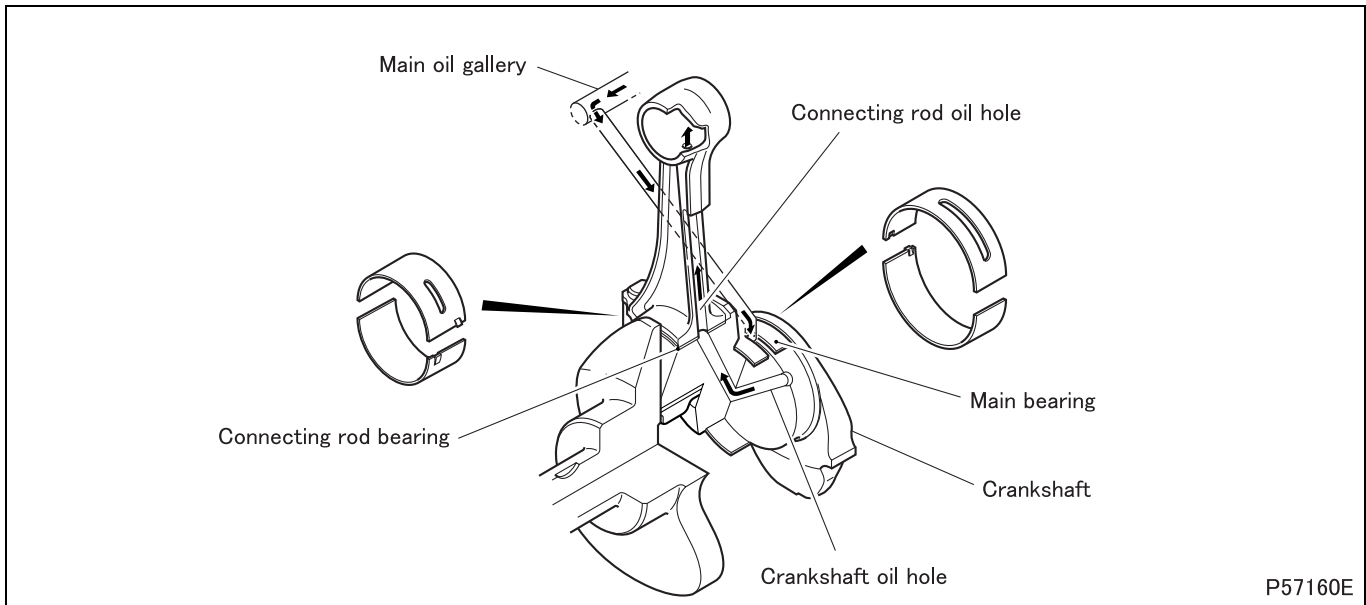

- Engine oil supplied through an oil passage in the crankshaft lubricates the big end (connecting rod bearing) of each connecting rod. Simultaneously, engine oil supplied through an oil passage in the connecting rod lubricates the connecting rod's small end.

5.2 Timing gears

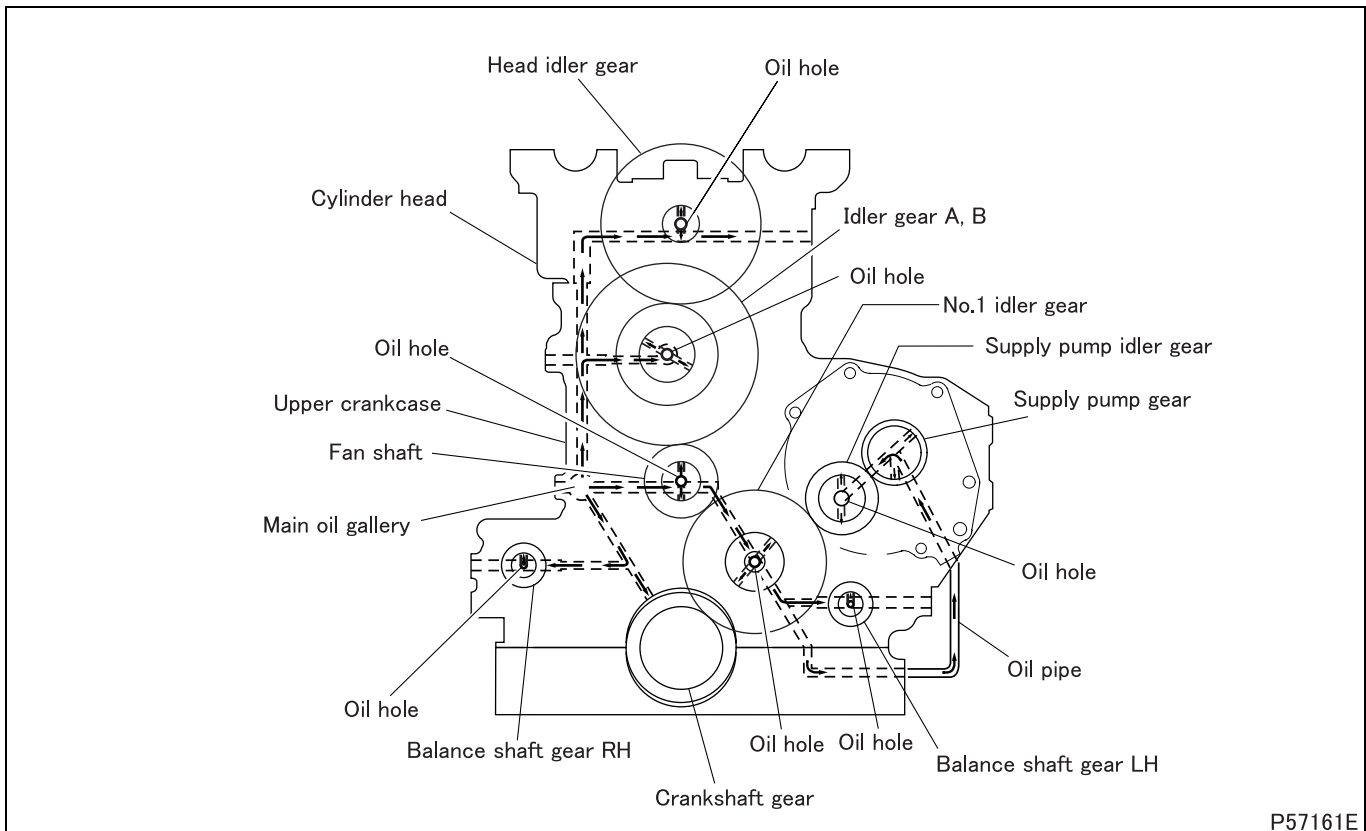

STRUCTURE AND OPERATION

5.3 Valve mechanism

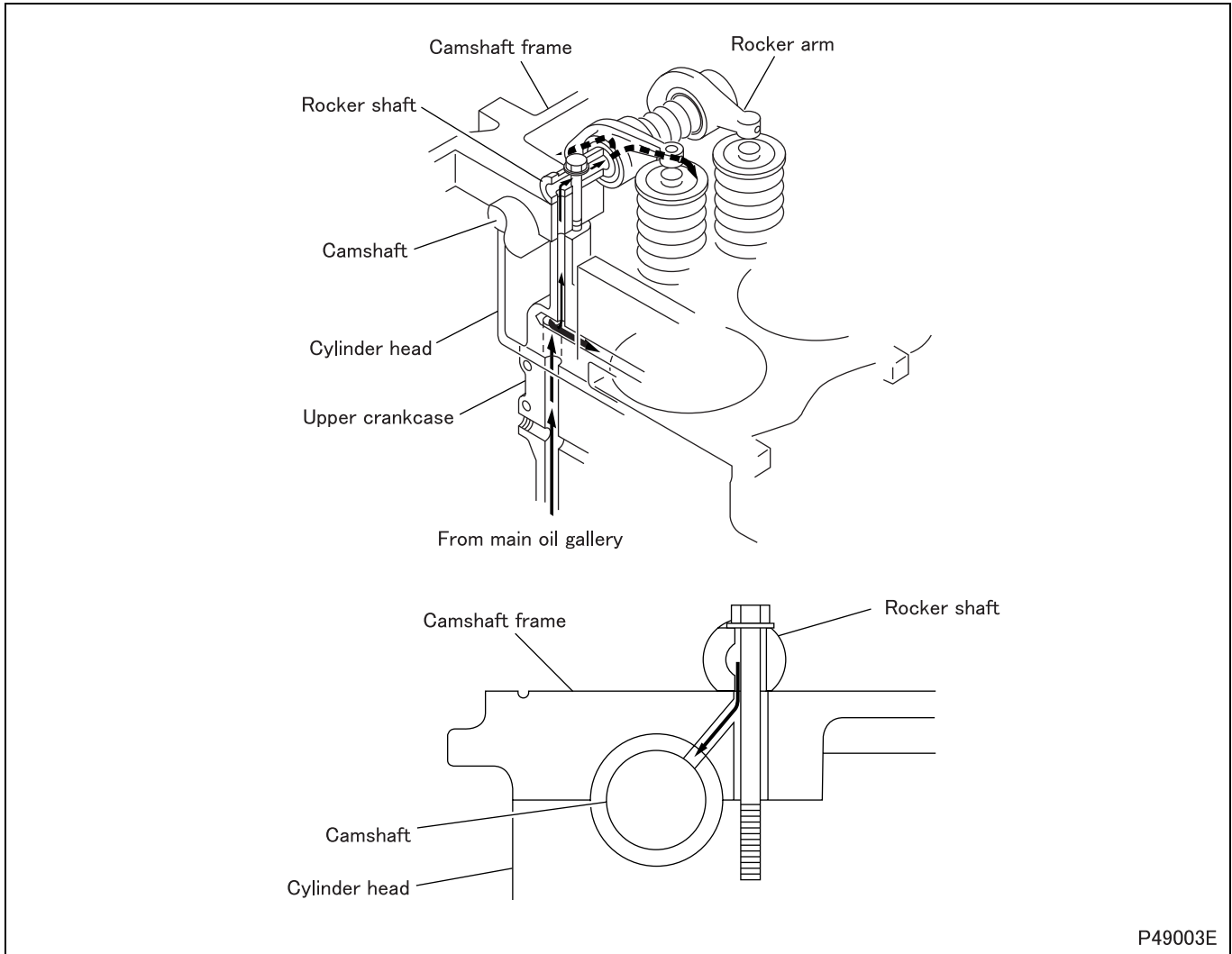

- The engine oil flows from the main oil gallery to the rocker shaft through the oil passages in the upper crankcase, cylinder head, and camshaft frame.
- The engine oil in the rocker shaft lubricates the rocker arms and camshaft, then returns to the oil pan.

5.4 Check valves and oil jets

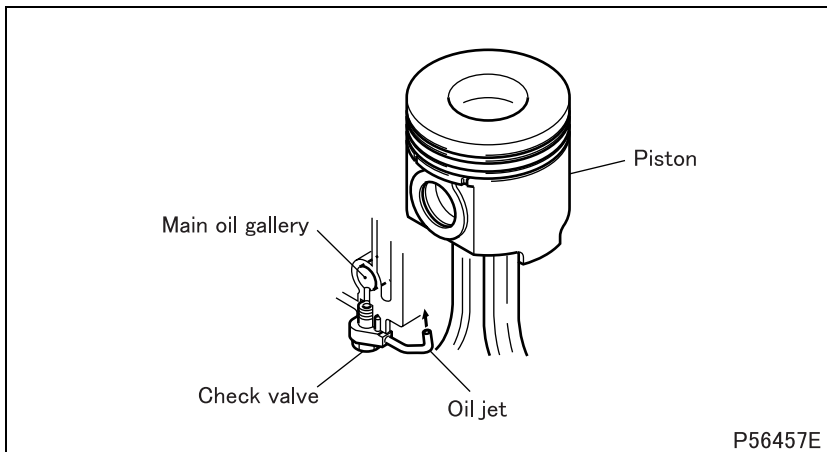

- An oil jet is fitted in the lower part of the main oil gallery for each cylinder.
- Engine oil is sprayed out of the oil jet into the piston to cool the piston.
- Each oil jet is fitted with a check valve that opens and closes at predetermined oil pressure levels. At low engine speeds, the check valve closes to maintain the required volume of oil in the lubrication system and prevent reductions in oil pressure.

5.5 Vacuum pump

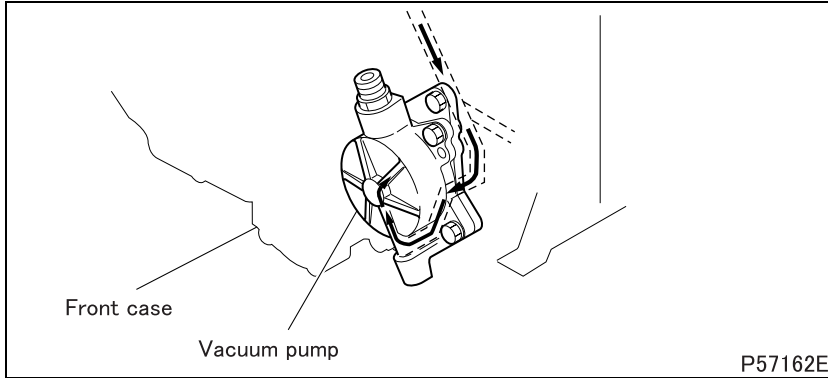

- Engine oil flows through the oil passages in the front case to the vacuum pump.
- The oil in the pump lubricates the vanes, and then is discharged into the front case from the air discharge port of the vacuum pump along with air, and returns to the oil pan.

5.6 Turbocharger

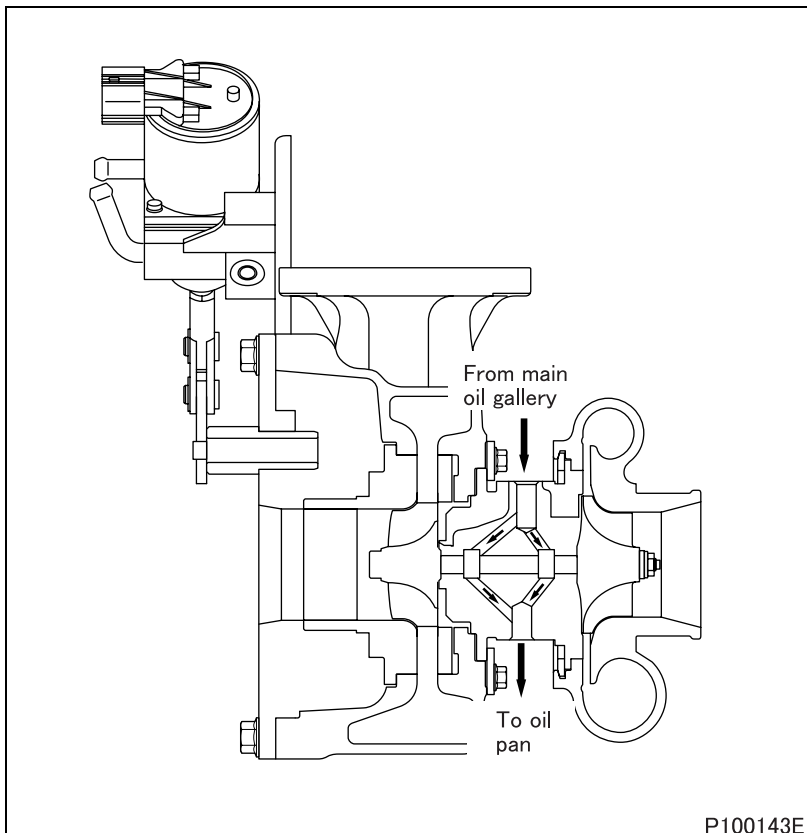

- Engine oil flows from the main oil gallery through the oil pipes to the turbocharger bearing housing and lubricates the inner surfaces of the bearing housing.
- The piston rings mounted on both sides of the turbine wheel shaft act as oil seals.

TROUBLESHOOTING

Symptoms		Engine is difficult to start	Overheating	Low oil pressure	Excessive oil consumption (oil leakage)	Reference Gr
Oil cooler	Incorrectly mounted element		○	○	○	
	Defective gasket		○	○	○	
	Defective O-ring		○	○	○	
	Clogged element		○	○		
	Damaged element		○	○	○	
	Weakened bypass valve spring		○			
Oil pump	Malfunctioning oil pump		○	○		
	Interference between oil pump gear and oil pump case and/or cover	○		○		
Oil filter	Incorrect installation				○	
	Clogged element		○	○		
	Defective gasket			○		
Weakened regulator valve spring				○		
Incorrectly mounted and/or clogged oil strainer			○	○		
Defective fan shaft front oil seal					○	Gr11
Defective crankshaft rear oil seal					○	
Incorrectly mounted front case					○	
Defective piston cooling oil jet(s)			○	○		
Incorrectly mounted gear lubrication oil jet				○		
Oil working its way up into combustion chamber(s) through piston rings					○	
Oil working its way down into combustion chamber(s) through valves					○	
Too high oil viscosity		○				
Poor oil quality			○			
Deterioration of oil			○			
Fuel mixed with oil			○			

M E M O

ON-VEHICLE INSPECTION AND ADJUSTMENT

1. Oil Filter Replacement

Lubricant and/or sealant

Mark	Points of application	Specified lubricant and/or sealant	Quantity
-	Oil filter	Engine oil (CJ-4)	Approx. 1 L {1.1 qts}

Special tools

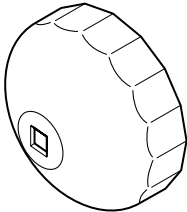
Mark	Tool name and shape	Part No.	Application
Ca	Oil filter element socket  P08550	MH061566	Removal of oil filter

WARNING

- Wipe up any spilled engine oil, as it can cause fires.

CAUTION

- Make sure not to put any engine oil on the V-belt when working on the oil filter. V-belts soiled with oil or grease may easily slip, resulting in deteriorated performance of the cooling system.

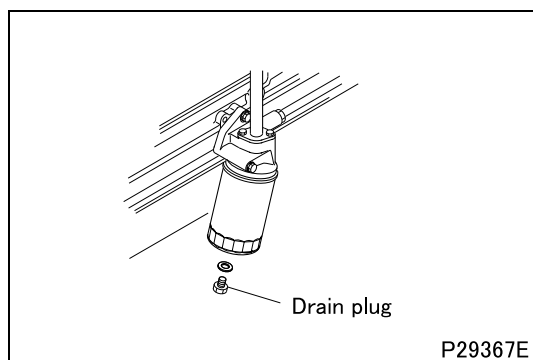

[Removal]

- Remove the drain plug and drain the oil out of the oil filter.

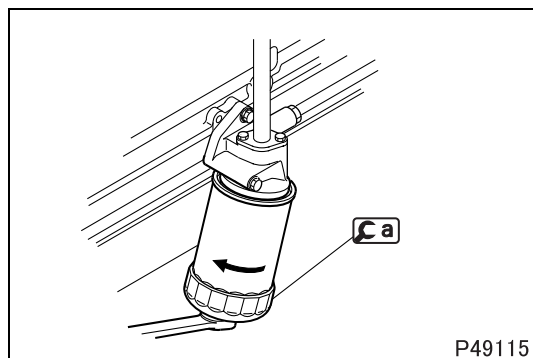

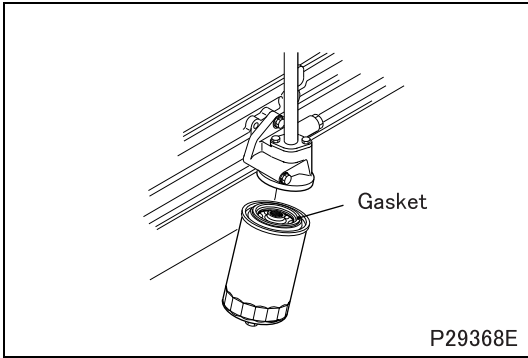

[Installation]

- Clean the oil filter mounting surfaces of the oil filter head.
- Apply a thin coat of engine oil on the oil filter gasket.
- Screw in the oil filter by hand until the gasket touches the oil filter head. Then, tighten the filter by turning it further by three quarters (3/4) of a turn.
- After installing the oil filter, start the engine and check that there are no oil leaks.
- Remove and reinstall the oil filter if it is leaky.
- Stop the engine and check the engine oil level.
- Add engine oil if necessary.

2. Engine Oil Replacement

Tightening torque (Unit: N-m {ft.lbs, kgf-m})

Mark	Parts to be tightened	Tightening torque	Remarks
-	Drain plug (oil filter)	9.8 ± 1.96 {7.2 ± 1.4, 1.0 ± 0.2}	-
-	Drain plug (oil pan)	34.3 to 43.1 {25 to 32, 3.5 to 4.4}	-

Lubricant and/or sealant

Mark	Points of application	Specified lubricant and/or sealant	Quantity
-	Oil filter	Engine oil (CJ-4)	Approx. 1 L {1.1 qts}
	Oil pan		Approx. 9 L {9.5 qts}

WARNING ⚠

- Wipe up any spilled engine oil, as it can cause fires.

CAUTION ⚠

- Make sure not to put any engine oil on the V-belt during engine oil replacement. V-belts soiled with oil or grease may easily slip, resulting in deteriorated performance of the cooling system.

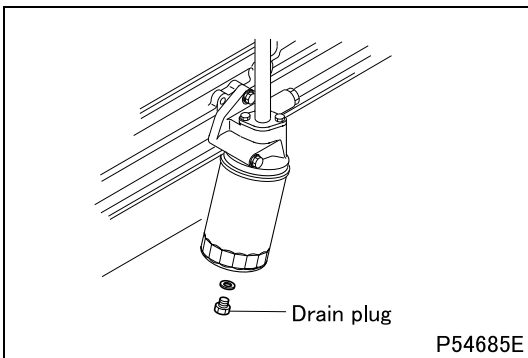

[Draining]

- Remove the filler cap.
- Remove the drain plugs of the oil filter and oil pan to drain out the engine oil.

ON-VEHICLE INSPECTION AND ADJUSTMENT

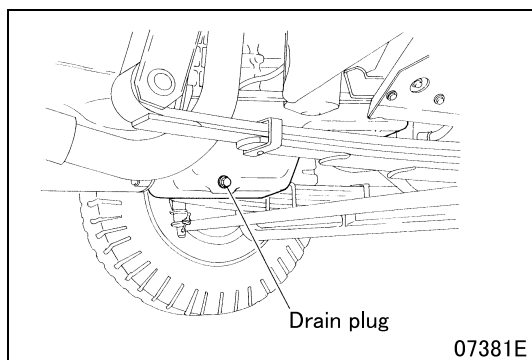

[Refilling]

- Tighten the drain plug to the specified torque, then pour a specified amount of new engine oil into the engine.
- Stop the engine and check the engine oil level.
- Add engine oil if necessary.

3. Engine Oil Level Inspection

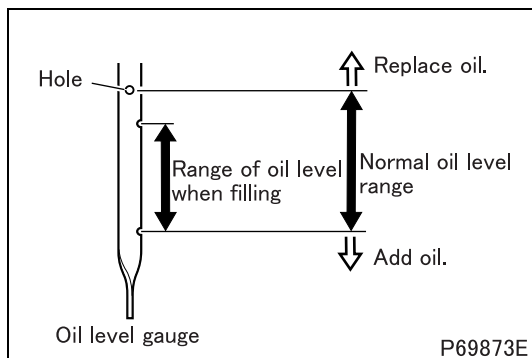

- When regenerating the DPF (diesel particulate filter), a part of the injected fuel may mix into the engine oil and may increase the quantity of oil.
- If the oil level is out of the normal range, add or replace the engine oil.

CAUTION

- **If the engine oil level exceeds the hole on the oil level gauge, replace the engine oil immediately as the oil has deteriorated and may cause seizure.**

- If remarkable increase of the engine oil is observed, check the following even the oil level is within the normal range.
 - Seizure of piston ring and piston
 - Excessive clearance between piston and cylinder liner

4. Oil Pressure Measurement

Service standards

Location	Maintenance item	Standard value	Limit	Remedy	
-	Oil pressure (oil temperature at 70 to 90°C {158 to 195°F})	No-load minimum speed	195 kPa {28 psi, 2.0 kgf/cm ² }	98 kPa {14 psi, 1.0 kgf/cm ² }	Inspect
		No-load maximum speed	295 to 490 kPa {43 to 71 psi, 3 to 5 kgf/cm ² }	195 kPa {28 psi, 2.0 kgf/cm ² }	

Tightening torque (Unit: N·m {ft.lbs, kgf·m})

Mark	Parts to be tightened	Tightening torque	Remarks
-	Engine oil pressure switch	7.8 to 14.7 {5.8 to 11, 0.8 to 1.5}	Sealant With cold engine

Lubricant and/or sealant

Mark	Points of application	Specified lubricant and/or sealant	Quantity
-	Engine oil pressure switch threads	ThreeBond 1215	As required

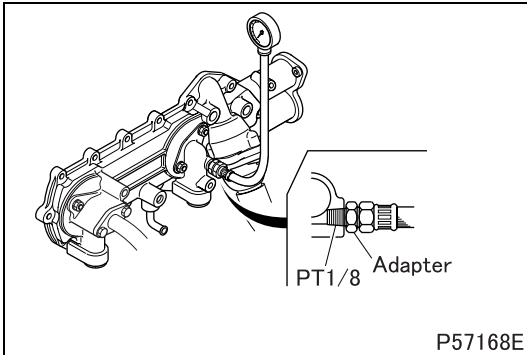
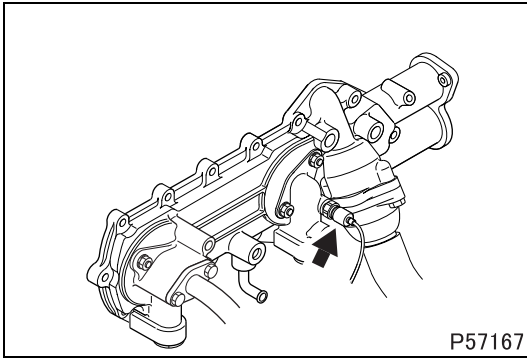

- Remove the engine oil pressure switch.
- Using an adapter, connect an oil pressure gauge to the engine oil pressure switch mounting hole.
- Warm up the engine until the oil temperature reaches 70 to 90°C {158 to 195°F}.
- Measure the oil pressure while running the engine at a minimum speed and then at maximum speed, both under no load.
- If the measurements are below the specified limits, overhaul the lubrication system.
- After taking the measurements, apply sealant to the threads of the oil pressure switch and tighten the switch to the specified torque.

CAUTION ⚠

- Reinstall the oil pressure switch only when the engine is cold.

OIL PAN, OIL STRAINER AND OIL JETS

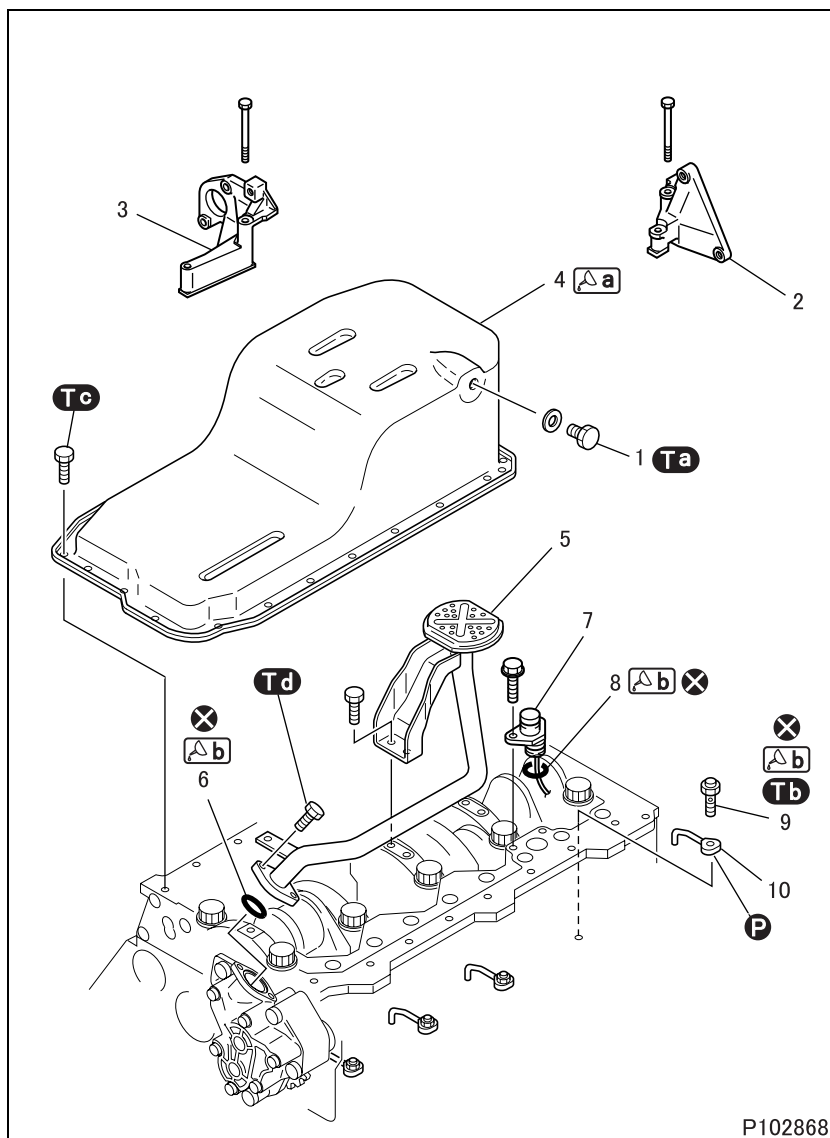

● Disassembly sequence

- 1 Drain plug
- 2 Stiffner RH
- 3 Stiffner LH
- 4 Oil pan
- 5 Oil strainer
- 6 O-ring
- 7 Engine oil level sensor
- 8 O-ring
- 9 Check valve
- 10 Oil jet

P: Locating pin

X: Non-reusable parts

● Assembly sequence

Follow the disassembly sequence in reverse.

CAUTION

- Make sure to tighten the check valve only to the specified torque. Overtightening it can cause defective operation, resulting in engine seizure.

P102868

Tightening torque (Unit: N·m {ft.lbs, kgf·m})

Mark	Parts to be tightened	Tightening torque	Remarks
Ta	Drain plug	34.3 to 43.1 {25 to 32, 3.5 to 4.4}	–
Tb	Check valve	29.4 {22, 3.0}	Wet
Tc	Bolt (oil pan mounting)	23.5 {17, 2.4}	–
Td	Bolt (oil strainer mounting)	23.2 {17, 2.4}	–

Lubricant and/or sealant

Mark	Points of application	Specified lubricant and/or sealant	Quantity
	Crankcase mounting surface of oil pan	ThreeBond 1207C	As required
	O-ring	Engine oil	As required
	Check valve threads		

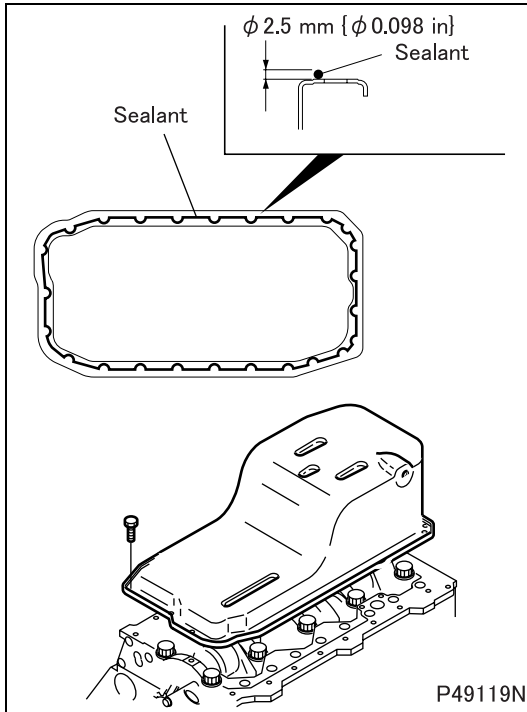
◆ Installation procedure ◆**■ Installation: Oil pan**

- Clean the mating surfaces of each part.
- Apply a bead of sealant to the mating surface of the oil pan evenly and without any breaks as shown in the illustration.
- Mount the oil pan within three minutes of applying the sealant. Make sure that the sealant stays in place.

CAUTION 

- Do not start the engine less than an hour after installation.
- If the oil pan mounting bolts were loosened or removed, be sure to reapply sealant.

OIL PUMP

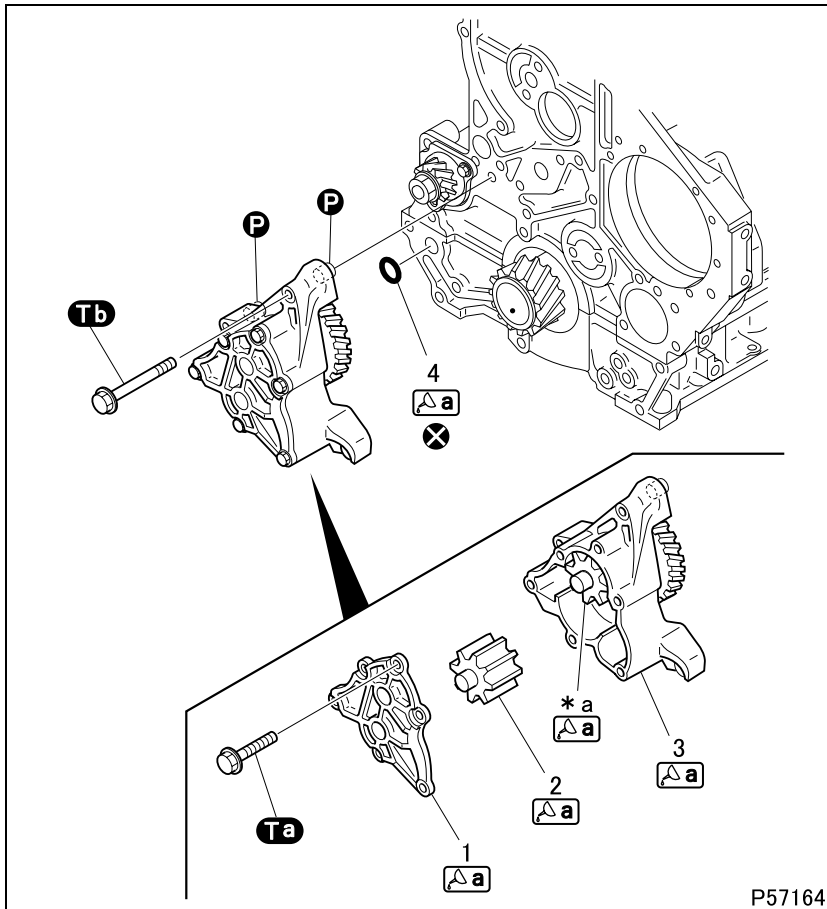

● Disassembly sequence

- 1 Oil pump
- 2 Oil pump cover
- 3 Driven gear
- 4 Gear and case assembly
- 5 O-ring

*a: Drive gear

Ⓟ: Locating pin

ⓧ: Non-reusable parts

● Assembly sequence

Follow the disassembly procedure in reverse.

Service standards (Unit: mm {in.})

Location	Maintenance item	Standard value	Limit	Remedy
1, 2	Oil pump cover-to-driven gear shaft clearance	0.04 to 0.075 {0.0016 to 0.0030}	0.15 {0.0059}	Replace
1, *a	Oil pump cover-to-drive gear shaft clearance	0.04 to 0.075 {0.0016 to 0.0030}	0.15 {0.0059}	Replace
2, 3	Gear and case assembly-to-driven gear shaft clearance	0.04 to 0.075 {0.0016 to 0.0030}	0.15 {0.0059}	Replace
2, 3, *a	Sinkage of each gear from gear and case assembly end surface	0.05 to 0.11 {0.0020 to 0.0043}	0.15 {0.0059}	Replace
	Gear and case assembly-to-tooth tip clearance for each gear	0.13 to 0.22 {0.0051 to 0.0087}	0.23 {0.0091}	Replace

Tightening torque (Unit: N·m {ft.lbs, kgf·m})

Mark	Parts to be tightened	Tightening torque	Remarks
ⓐ	Bolt (oil pump cover mounting)	27.4 {20, 2.8}	—
ⓑ	Bolt (oil pump mounting)	28 {21, 2.9}	—

Lubricant and/or sealant

Mark	Points of application	Specified lubricant and/or sealant	Quantity
ⓐ	Oil pump contact surfaces	Engine oil	As required
	O-ring		

Special tools (Unit: mm {in.})

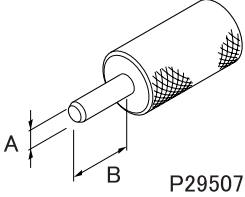
Mark	Tool name and shape	Part No.	Application						
Ca	Pump cover pin <table border="1"> <tr> <td>A</td> <td>B</td> </tr> <tr> <td>$\phi 7 \begin{smallmatrix} 0 \\ -0.14 \end{smallmatrix}$</td> <td>20 {0.79}</td> </tr> <tr> <td>$\{\phi 0.28 \begin{smallmatrix} 0 \\ -0.0055 \end{smallmatrix}\}$</td> <td></td> </tr> </table>	A	B	$\phi 7 \begin{smallmatrix} 0 \\ -0.14 \end{smallmatrix}$	20 {0.79}	$\{\phi 0.28 \begin{smallmatrix} 0 \\ -0.0055 \end{smallmatrix}\}$		MH063431	Installation of oil pump cover
		A	B						
$\phi 7 \begin{smallmatrix} 0 \\ -0.14 \end{smallmatrix}$	20 {0.79}								
$\{\phi 0.28 \begin{smallmatrix} 0 \\ -0.0055 \end{smallmatrix}\}$									
									

◆ Inspection procedure ◆

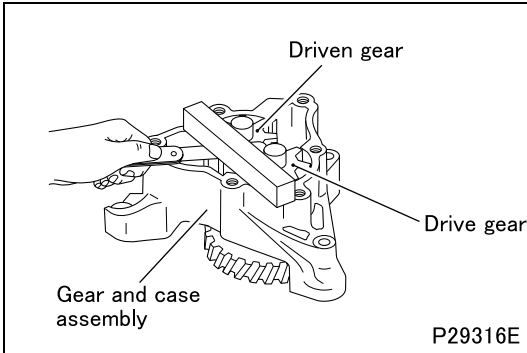

■ Inspection: Driven gear, drive gear and gear and case assembly

- Carry out the following inspection. Replace the oil pump if any defects are found.

(1) Sinkage of each gear from gear and case assembly end surface

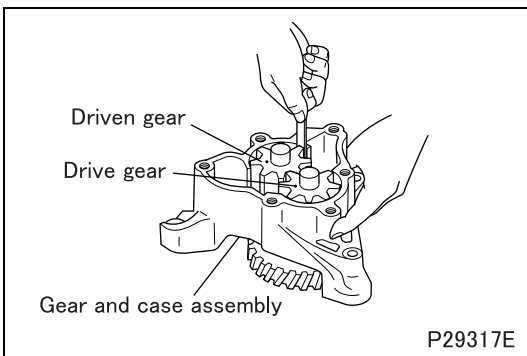

(2) Gear and case assembly-to-tooth tip clearance for each gear

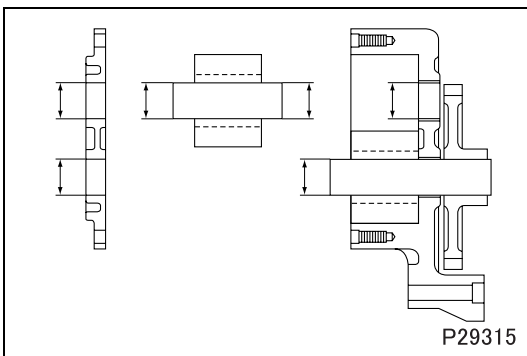

■ Inspection: Oil pump cover, driven gear, and gear and case assembly

- Measure the clearance between each gear's shaft and the oil pump cover, as well as between each gear's shaft and the gear and case assembly.
- If the measurements are not within the standard value range, replace the oil pump.

OIL PUMP

◆ Installation procedure ◆

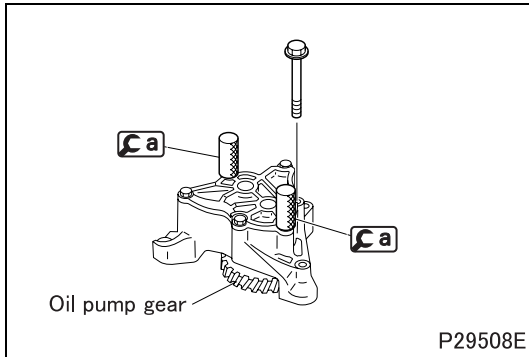

■ Installation: Oil pump cover and gear and case assembly

- Apply engine oil to each component.
- Hold the oil pump cover in place on the gear and case assembly by fitting two **Ca**s in the illustrated locations.
- Install a bolt into an empty bolt hole and tighten it to the specified torque.
- Remove the two **Ca**s. Install the rest of the bolts and tighten them to the specified torque.
- After installing all the bolts, turn the oil pump gear by hand and check that it rotates smoothly.
- Disassemble and reassemble the oil pump cover and gear and case assembly if the oil pump gear does not rotate smoothly.

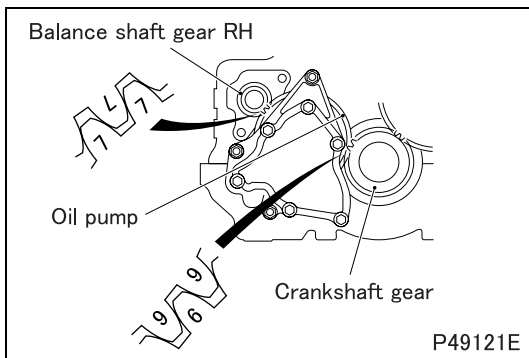

■ Installation: Oil pump

- Place the No.1 cylinder piston at top dead center to bring the crankshaft gear to an appropriate position.
- Inject approximately 5 cm³ {0.3 cu. in.} of engine oil.
- Align the mating mark "6" on the crankshaft gear and the mating mark "7" on the balance shaft gear RH with the corresponding mating marks on the oil pump gear, and then install the oil pump gear.

M E M O

OIL FILTER

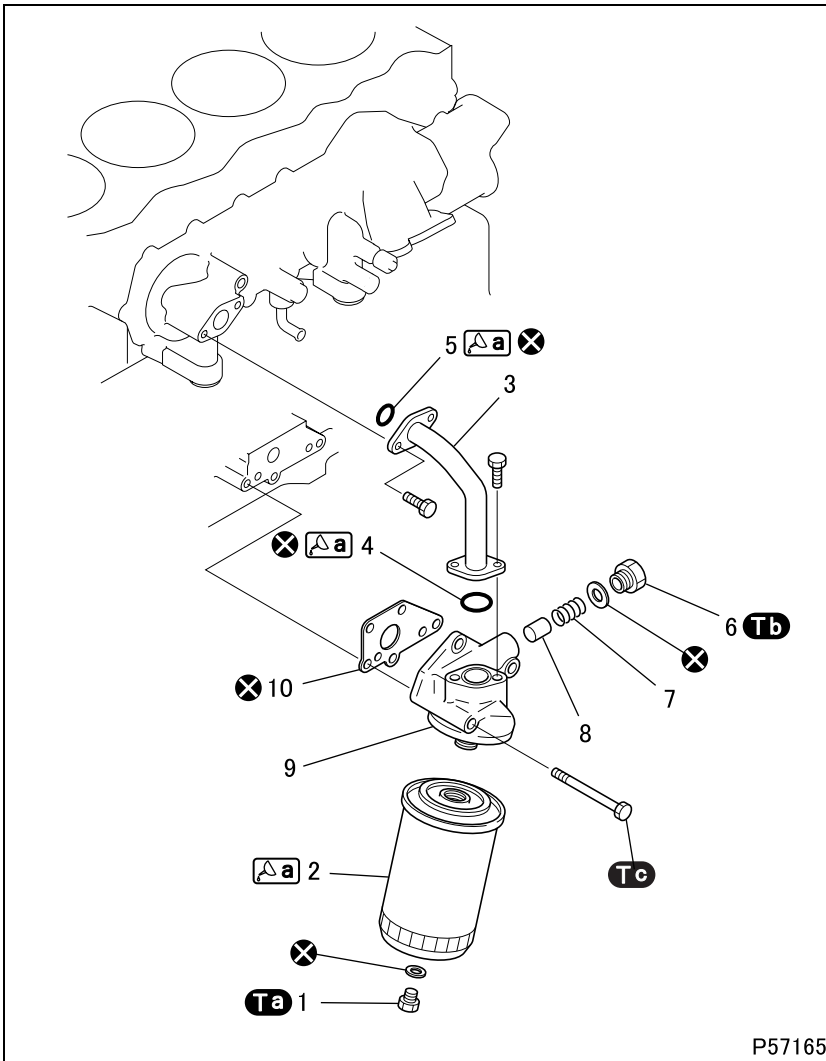

P57165

● Disassembly sequence

- 1 Drain plug
- 2 Oil filter
- 3 Oil pipe
- 4 O-ring
- 5 O-ring
- 6 Plug
- 7 Regulator valve spring
- 8 Regulator valve
- 9 Oil filter head
- 10 Gasket

⊗: Non-reusable parts

● Assembly sequence

Follow the disassembly sequence in reverse.

WARNING ⚠

- Wipe up any spilled engine oil, as it can cause fires.

CAUTION ⚠

- Make sure not to put any engine oil on the V-belt when working on the oil cooler and oil filter. V-belts soiled with oil or grease may easily slip, resulting in deteriorated performance of the cooling system.
- Make sure to install the gasket in the correct position so that it does not cover up the oil hole.

Service standards (Unit: mm {in.})

Location	Maintenance item	Standard value	Limit	Remedy
7	Load of installed regulator valve spring (installed length: $39^{+0.3}_0$ { $1.54^{+0.012}_0$ })	93.5 ± 0.5 N { 21 ± 0.1 lbs, 9.5 ± 0.05 kgf}	–	Replace

Tightening torque (Unit: N-m {ft.lbs, kgf-m})

Mark	Parts to be tightened	Tightening torque	Remarks
Ta	Drain plug	9.8 ± 1.96 { 7.2 ± 1.4 , 1.0 ± 0.2 }	–
Tb	Plug (regulator valve mounting)	60 {44, 6.0}	–

Lubricant and/or sealant

Mark	Points of application	Specified lubricant and/or sealant	Quantity
a	Oil filter gasket	Engine oil	As required
	O-ring		

Special tools

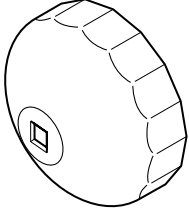
Mark	Tool name and shape	Part No.	Application
	Oil filter element socket  P08550	MH061566	Removal of oil filter

◆ Removal procedure ◆

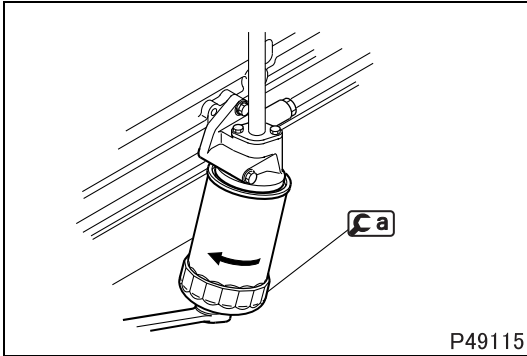

■ Removal: Oil filter

◆ Installation procedure ◆

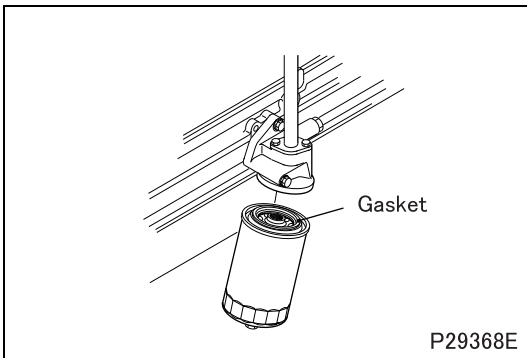

■ Installation: Oil filter

- Clean the oil filter mounting surface of the oil filter head.
- Apply a thin coat of engine oil on the oil filter gasket.
- Screw in the oil filter by hand until the gasket touches the oil filter head. Then, tighten the filter by turning further by three quarters (3/4) of a turn.
- After installing the oil filter, start the engine and check that there are no oil leaks from the gasket.
- Remove and reinstall the oil filter if it is leaky.
- Stop the engine and check the engine oil level.
- Add engine oil if necessary.

OIL COOLER

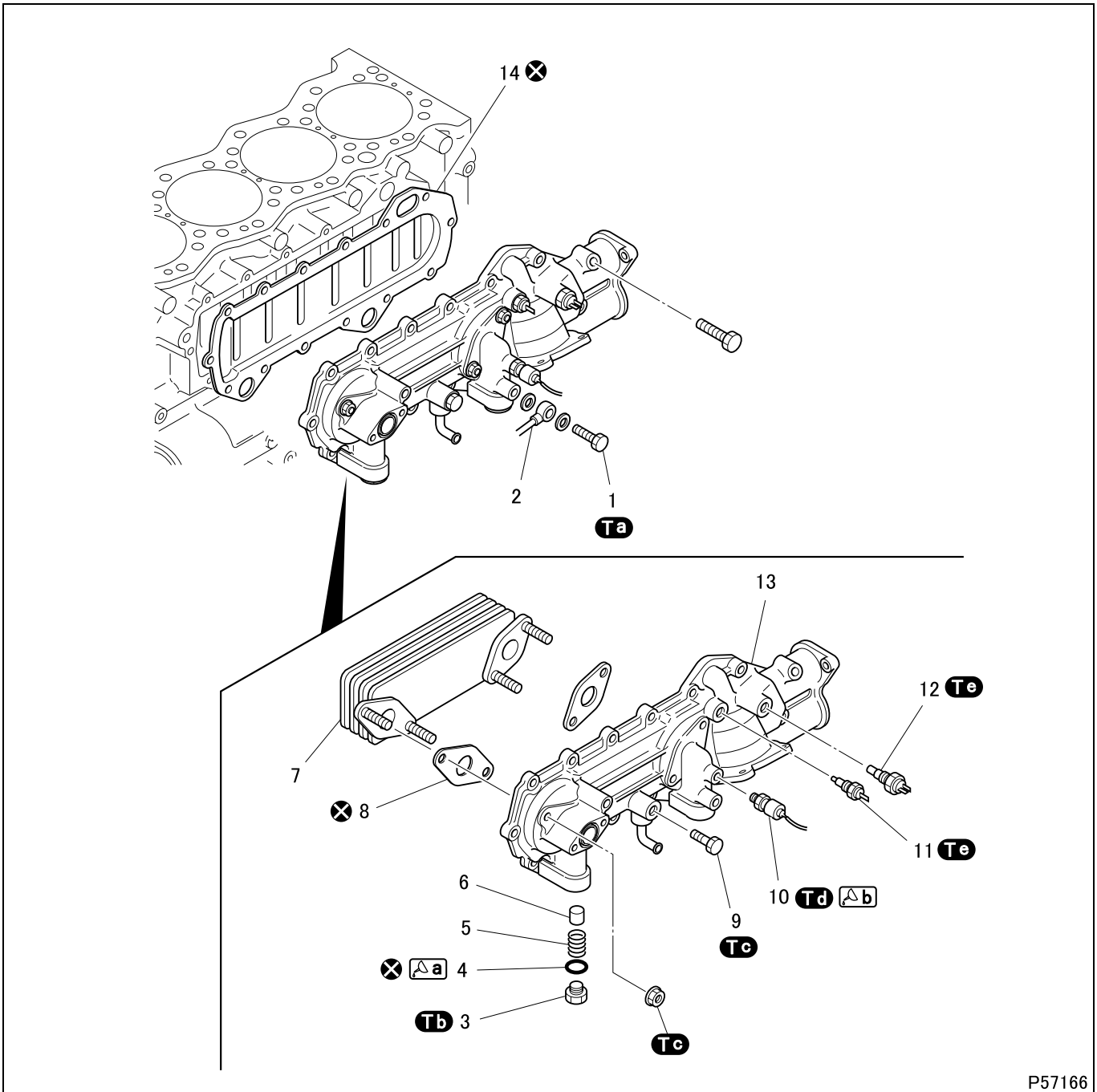

P57166

● Disassembly sequence

- | | | |
|-----------------------|---|---|
| 1 Eyebolt | 7 Oil cooler element | 12 Coolant temperature sensor
(for engine control) |
| 2 Oil pipe | 8 Gasket | 13 Oil cooler body |
| 3 Plug | 9 Water drain valve | 14 Gasket |
| 4 O-ring | 10 Engine oil pressure switch | |
| 5 Bypass valve spring | 11 Coolant temperature sensor
(for water temperature gage) | |
| 6 Bypass valve | | |

⊗: Non-reusable parts

● Assembly sequence

Follow the disassembly sequence in reverse.

Service standards (Unit: mm {in.})

Location	Maintenance item	Standard value	Limit	Remedy
5	Load of bypass valve spring (installed length: $48_{-0.5}^0$ { $1.89_{-0.02}^0$ })	95.3 ± 4.9 N { 21 ± 1.1 lbs, 9.7 ± 0.5 kgf}	–	Replace
7	Air leakage from oil cooler element (air pressure: 980 kPa {140 psi, 10 kgf/cm ² } for 15 seconds)	0 cm ³ {0 cu. in.}	–	Replace

Tightening torque (Unit: N·m {ft.lbs, kgf·m})

Mark	Parts to be tightened	Tightening torque	Remarks
Ta	Eyebolt (oil pipe mounting)	21.6 {16, 2.2}	–
Tb	Plug	30 ± 5 { 22 ± 3.7 , 3.1 ± 0.5 }	–
Tc	Nut (oil cooler element mounting) Water drain valve	25 ± 5 { 1.8 ± 3.7 , 2.5 ± 0.5 }	–
Td	Engine oil pressure switch	12 {8.9, 1.2}	Sealant With cold engine
Te	Coolant temperature sensor (for water temperature gage)	34.3 {25, 3.5}	–
Tf	Coolant temperature sensor (for engine control)	39{29, 4}	

Lubricant and/or sealant

Mark	Points of application	Specified lubricant and/or sealant	Quantity
a	O-ring	Engine oil	As required
b	Engine oil pressure switch threads	ThreeBond 1215	As required

◆ Inspection procedure ◆

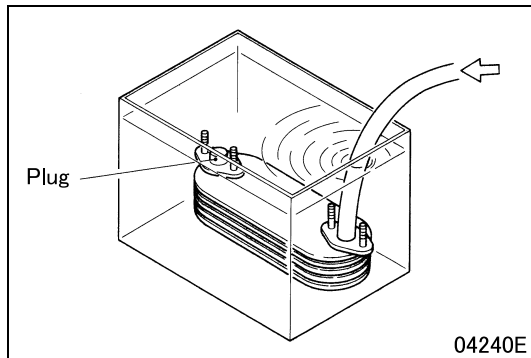

■ Inspection: Oil cooler element

- Plug the outlet of the oil cooler element and connect a hose to the engine oil inlet port. Then, immerse the oil cooler element in a tank of water.
- Apply an air pressure of 980 kPa {140 psi, 10 kgf/cm²} for 15 seconds through the hose, and check for any air leaks.
- Replace the element if it leaks air.