

INDEX

STRUCTURE AND OPERATION

- 1. General Description 13EB-2
- 2. Electronic Control System 13EB-2
- 3. Electronic Control Unit Connection Diagram..... 13EB-6

TROUBLESHOOTING

- 1. Diagnosis Procedure..... 13EB-8
- 2. Diagnostic Precautions 13EB-8
- 3. Inspection Based on Diagnosis Codes..... 13EB-9
- 4. Multi-Use Tester Service Data..... 13EB-13
- 5. Actuator Tests Performed Using Multi-Use Tester 13EB-14
- 6. Works Required When Replacing the Multifunction Vehicle
Control Unit (MVCU)..... 13EB-14
- 7. Inspections Performed at Electronic Control Unit
Connectors 13EB-15

INSPECTION OF ELECTRICAL EQUIPMENT 13EB-16

INSTALLED LOCATIONS OF PARTS 13EB-18

ELECTRIC CIRCUIT DIAGRAM 13EB-22

STRUCTURE AND OPERATION

1. General Description

- The MVCU (Multi function Vehicle Control Unit) is an integrated electronic control unit which has the following functions:
 - Auto cruise function
 - Vehicle speed limiting (SLD) function <Configurable for vehicles with automatic transmission (except Crew-cab models)>
- For these functions, MVCU receives the sensor and switch information from other ECUs via CAN communication system.
- In the auto cruise function, the target vehicle speed is set using the main switch, set switch and resume switch, and the MVCU maintains the set speed by controlling the engine.
- The vehicle speed limiting (SLD) function is designed to send output signals to the engine ECU to restrict the maximum vehicle speed to a preset speed limit regardless of the accelerator pedal operation when the vehicle speed reaches the speed limit on flat or uphill road.
This vehicle speed limiting (SLD) function is inactive in the initial setting of MVCU. To activate this, consult your nearest STERLING TRUCKS dealer or STERLING TRUCKS CORPORATION.
- The MVCU also has the self-diagnosis function to diagnose major components and warns the driver if any abnormality is found.

2. Electronic Control System

2.1 System block diagram

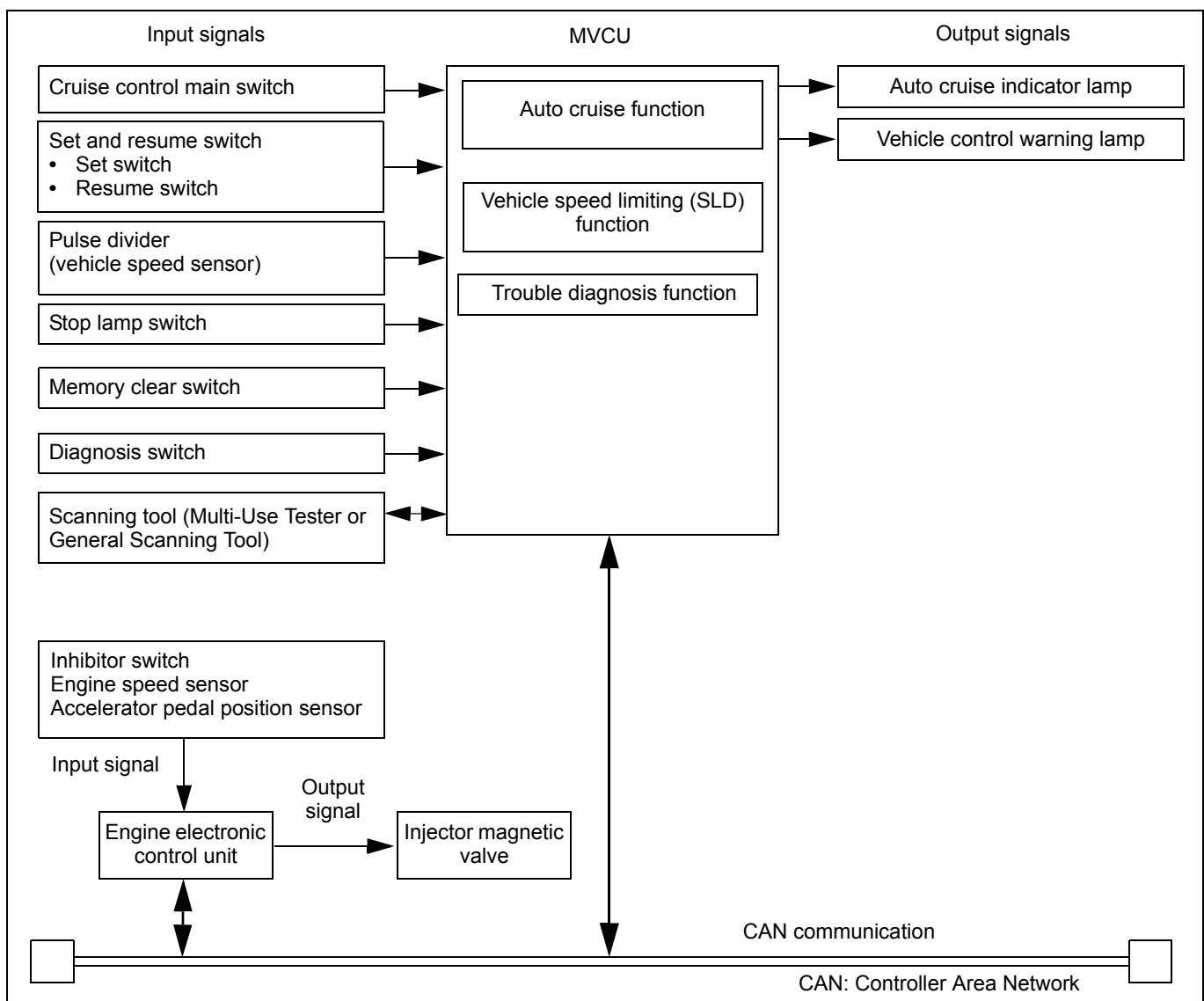

Part name	Function/operation
Cruise control main switch	ON-OFF control of auto cruise system
Set switch	Selection and change of desired cruising speed
Resume switch	Resumption and change of canceled cruising speed
Pulse divider (vehicle speed sensor)	Detection of vehicle speed
Stop lamp switch	Detection of brake pedal depression (lamp lit on pedal being pressed)
Memory clear switch	Clearing of existing diagnosis code, output of earlier diagnosis codes
Diagnosis switch	Output of diagnosis codes
Scanning tool (Multi-Use Tester or General Scanning Tool)	Communication between scanning tool (Multi-Use Tester or General Scanning Tool) and MVCU
Auto cruise indicator lamp	Indication of system in operation
Vehicle control warning lamp	Indication of system failure
CAN communication (engine electronic control unit)	MVCU outputs recognized vehicle data on CAN so that engine electronic control unit receives necessary data for control. Engine electronic control unit outputs necessary signals to MVCU for appropriate control of individual systems.

2.2 Auto cruise function

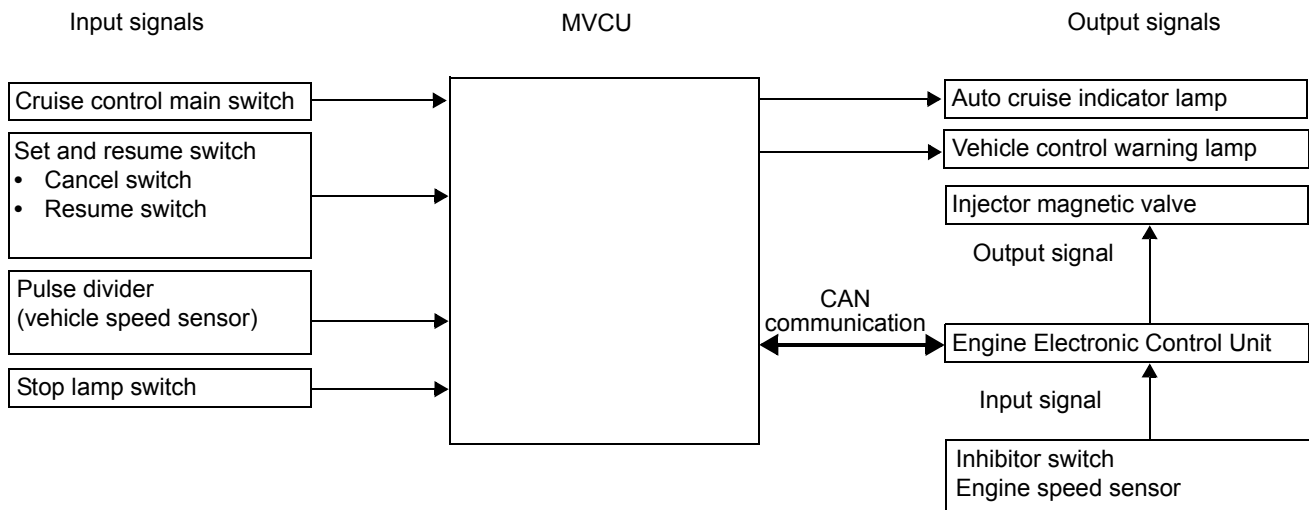

- In the auto cruise function, the target vehicle speed is set using the main switch, set switch and resume switch, and the MVCU maintains the set speed by controlling the engine.

STRUCTURE AND OPERATION

(1) Setting the auto cruise function

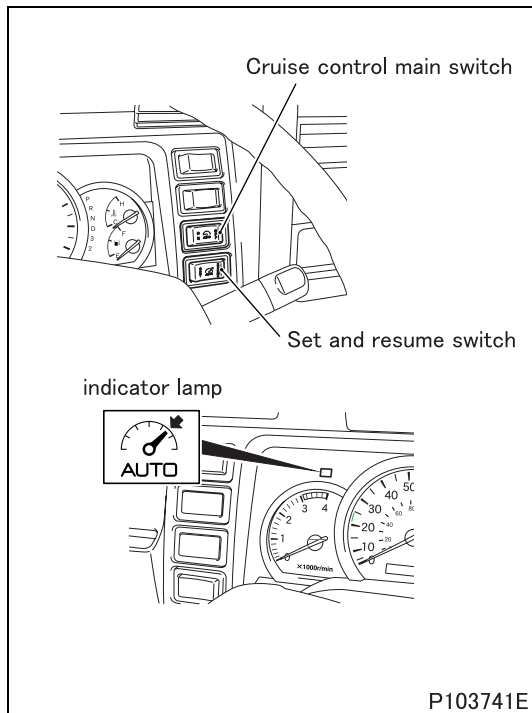

- The operation of the auto cruise function using the set and resume switch is as follows:

(1.1) Setting condition

- To activate the auto cruise function, the following conditions should be met:
 - Shift lever is in 4th or higher gear position.
 - Vehicle speed is increased to approx. 40 km/h {25 MPH} or higher.
 - The cruise control main switch is in ON position.
 - The brake pedals are released.

(1.2) Set switch (“SET” side of the set and resume switch)

- This switch is used to set or change the target vehicle speed.

Setting the vehicle speed

- Accelerate to a desired speed using the accelerator pedal.
- In this condition, press and release the set switch. The target vehicle speed is set when the switch is released and the auto cruise indicator lamp illuminates.

Lowering the set speed

- During auto cruise driving, pressing the set switch decelerates the vehicle speed. Press the set switch to lower the vehicle speed and, when the speed lowers to a desired speed, release the set switch. A new target vehicle speed is set at that moment.

Raising the set speed

- Press the accelerator pedal and raise the vehicle speed. When the desired speed is reached, press and release the set switch. A new target vehicle speed is set at that moment.

(1.3) Resume switch (“RESUME” side of the set and resume switch)

- This switch is used to resume the auto cruise control when the control is temporarily disengaged or to change the target vehicle speed.

Resuming the auto cruise control (target speed)

- During auto cruise driving when the control has temporarily disengaged due to braking or other reason, press and release the resume switch. The auto cruise control is reengaged and it regulates the vehicle speed to a former target speed.

Raising the set speed

- During auto cruise driving, pressing the resume switch accelerates the vehicle speed. Press the resume switch to raise the vehicle speed and, when the speed rises to a desired speed, release the resume switch. A new target vehicle speed is set at that moment.

(2) Disengaging the auto cruise control

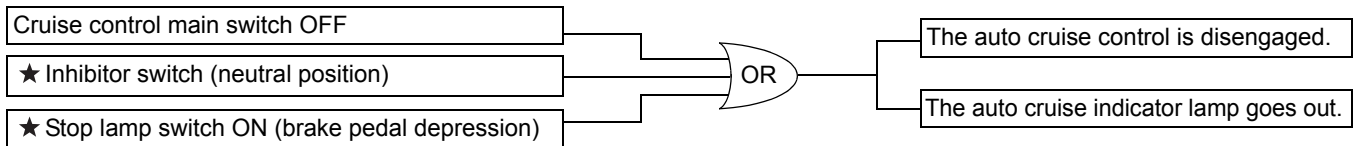

The condition marked ★ disengages the auto cruise control temporarily.

2.3 Vehicle speed limiting (SLD) function

- This vehicle speed limiting (SLD) function is inactive in the initial setting of MVCU.
- To activate this function, ask your nearest STERLING TRUCKS dealer or STERLING TRUCKS CORPORATION.

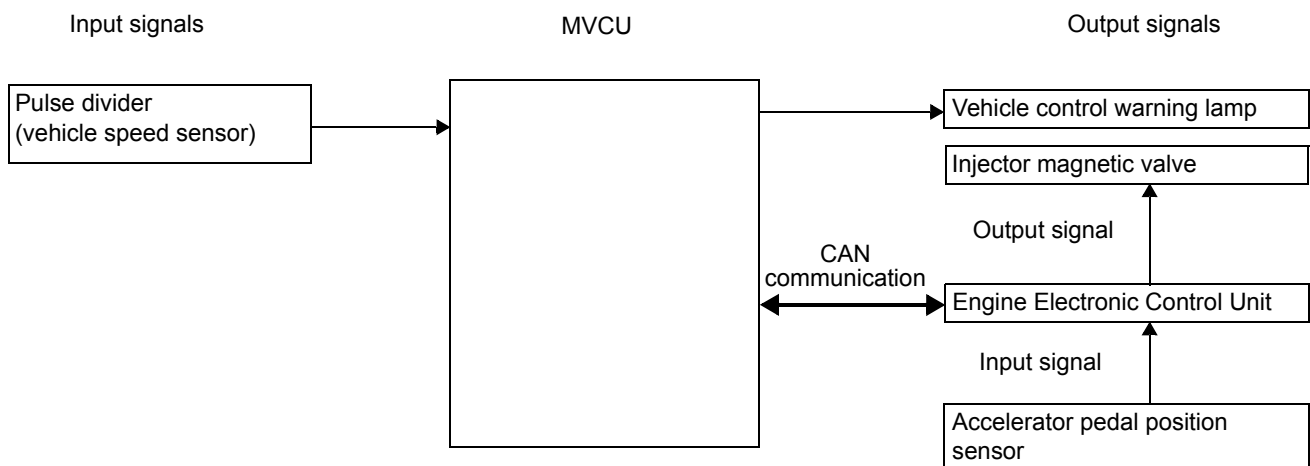

- The vehicle speed limiting (SLD) function is designed to send output signals to the engine ECU to restrict the maximum vehicle speed to a preset speed limit regardless of the accelerator pedal operation when the vehicle speed reaches the speed limit on flat or uphill road.

2.4 Trouble diagnosis function

- The system constantly performs trouble diagnosis to determine if various sensors, etc. malfunction when the starter switch is ON. When a failure is detected, trouble information is indicated on the meter cluster to inform the driver to that effect. At the same time, the location of the trouble is stored in memory as a diagnosis code to start restricted in-trouble control.
- While in trouble, the system's control functions are restricted to ensure safety of the vehicle and its driver. Diagnosis codes stored in memory can be retrieved on the Multi-Use Tester or through blinking warning lamp.
- Diagnosis codes are different in kind between the Multi-Use Tester and blinking warning lamp.

STRUCTURE AND OPERATION

3. Electronic Control Unit Connection Diagram

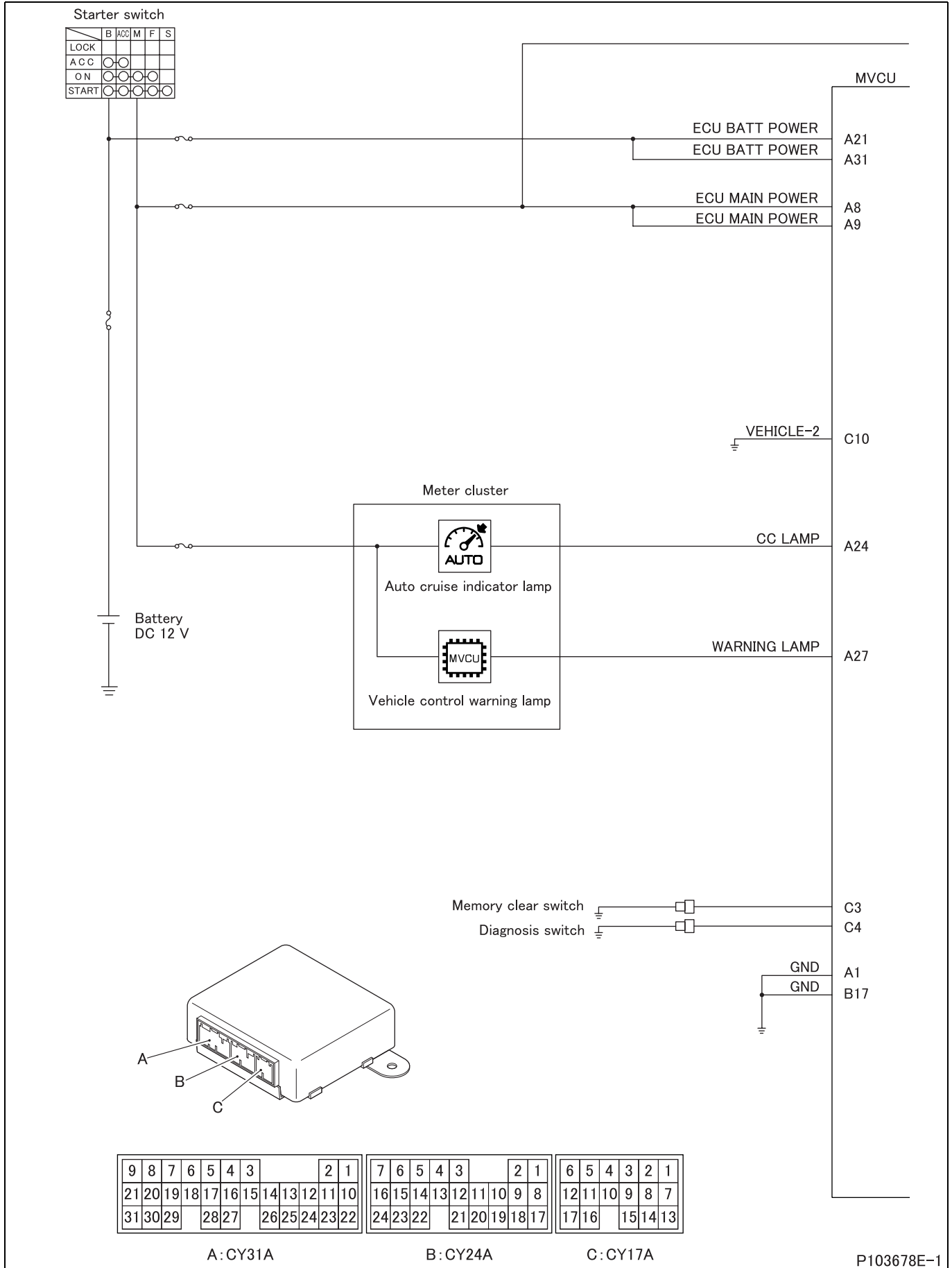

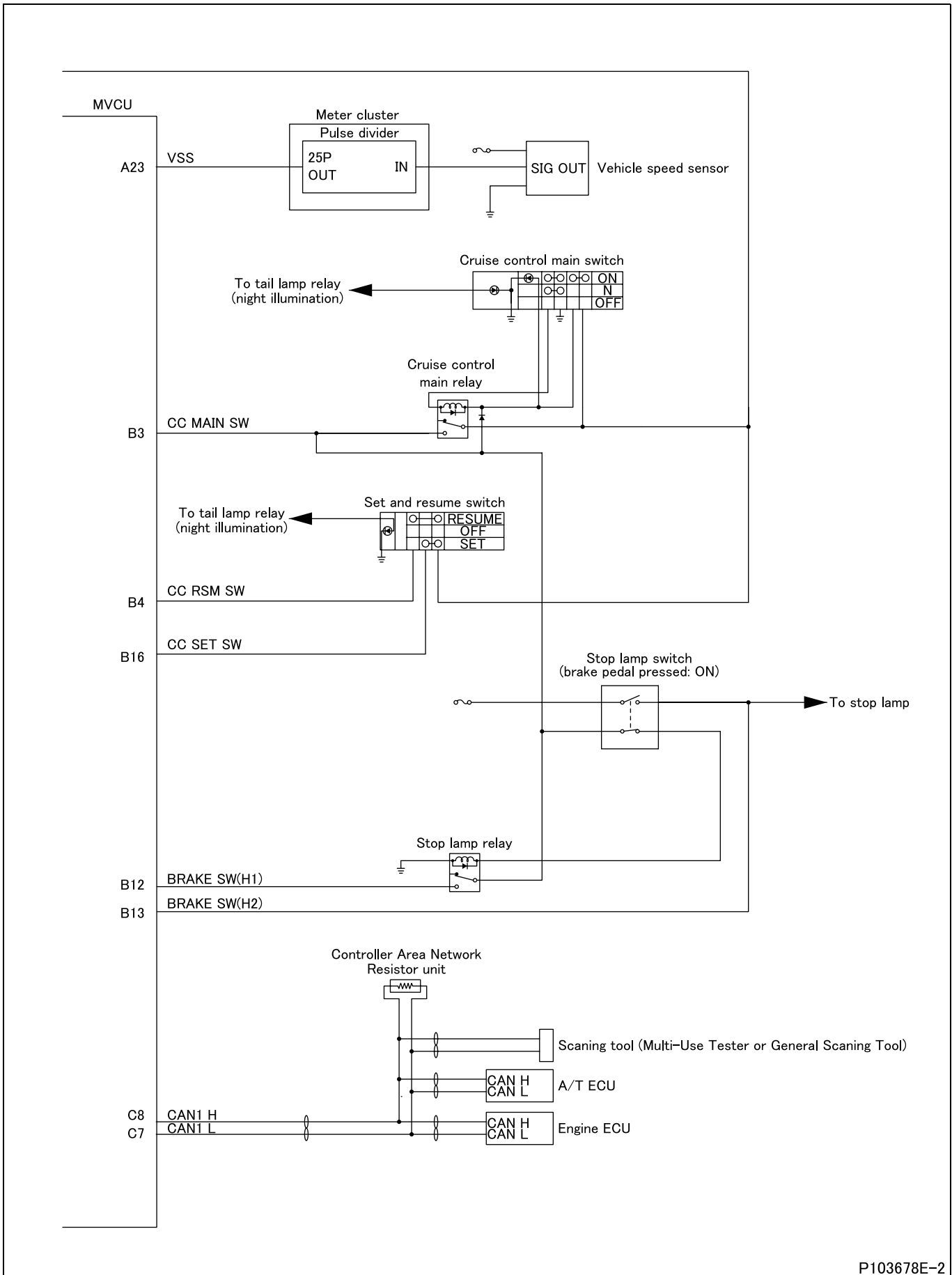

TROUBLESHOOTING

1. Diagnosis Procedure

- The system can be efficiently inspected for faults using a Multi-Use Tester.
System inspection can be accomplished basically in two ways according to trouble symptom and diagnosis code as shown below.
 - Check against each diagnosis code stored in memory by the electronic control unit
 - Response to transient fault

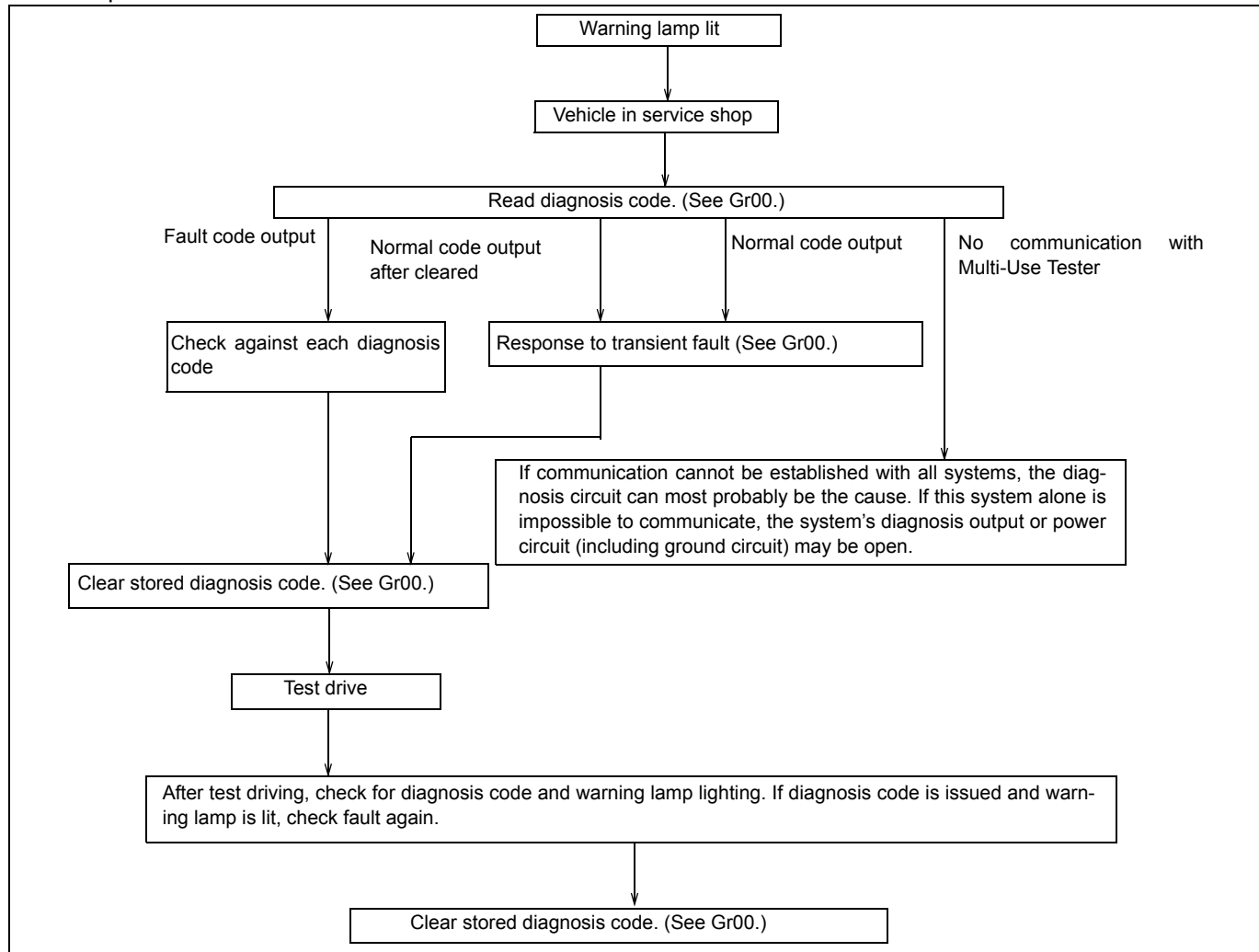

2. Diagnostic Precautions

- Before measuring voltage, check the battery for charged condition and specific gravity. If system inspection is performed with the battery uncharged or reduced in specific gravity, accurate measurements cannot be achieved.
- To avoid having electrical parts damaged, set the starter switch and lighting switch to LOCK or OFF before disconnecting and reconnecting battery cables.
- Before disconnecting connectors, set the starter switch to LOCK or OFF, then allow at least 20 seconds. Voltage may remain in electric parts or connected circuit.
- When performing measurement with the tester, handle the test bar carefully so that it does not damage internal circuit and other electrical parts of the electronic control unit to result in a short-circuit failure between terminals in connector or between connector and car body.
- Resistance is affected by temperature. Determine the necessity of resistance measurement following given temperature specification as a guide. Otherwise, use normal temperature (10 to 35°C {50 to 95°F}) as the measuring condition.

CAUTION

- When replacing the MVCU with a new one, writing of data in the new MVCU is required. (See “Works Required When Replacing the Multifunction Vehicle Control Unit (MVCU)”.)

3. Inspection Based on Diagnosis Codes

3.1 List of diagnosis codes

NOTE

- Diagnosis codes are different in kind between the Multi-Use Tester and blinking warning lamp.
- The Multi-Use Tester issues diagnosis codes that tell more in detail.

Code	Message	Warning lamp blinking
–	OK	01
P0500	Vehicle Speed Sensor	06
P0504	Brake SW	11
P1002	Battery Voltage	02
P1003	Battery Terminal	03
P1004	Main Voltage	04
P1007	MVCU	07
P1008	Vehicle Identification	08
P1009	Non Coding	09
P1016	Cruise Variation Identify	16
U0100	CAN Communication	05
U1013	Engine ECU Cruise Control	13
U1031	Engine ECU Speed Limiting	31

3.2 Diagnosis code generation conditions and inspection items

P0500: Vehicle Speed Sensor (Warning lamp: 06)

Generation condition		Engine speed at 1000 rpm or higher, clutch pedal released, transmission neutral switch in ON position and the vehicle speed at 0.75 km/h {0.47 MPH} or lower.
Recoverability		System recovers (power is re-supplied to electronic control unit) if signal becomes normal when starter switch is turned OFF → ON.
Control effected by electronic control unit		<ul style="list-style-type: none"> • Auto cruise control and vehicle speed limiting (SLD) control is suspended. • Occurrence of trouble with vehicle speed limiting function sent through CAN bus.
Inspection	Service data	03: Vehicle Speed
	Electronic control unit connector	01 : Vehicle speed sensor
	Electrical equipment	#265: Vehicle speed sensor
	Electric circuit diagram	Vehicle sensor system

P0504: Brake SW (warning lamp: 11)

Generation condition		Stop lamp switch (H1, H2) signals are not identical.
Recoverability		System recovers (power is re-supplied to electronic control unit) if signal becomes normal when starter switch is turned OFF → ON.
Control effected by electronic control unit		<ul style="list-style-type: none"> • Auto cruise control is suspended. • Vehicle speed limiting (SLD) control is continued.
Inspection	Service data	24: Brake SW 1, 25: Brake SW 2
	Electronic control unit connector	02 : Stop lamp switch
	Electrical equipment	#042: Stop lamp switch
	Electric circuit diagram	Stop lamp system

TROUBLESHOOTING

P1002: Battery Voltage (Warning lamp: 02)

Generation condition		MVCU power terminal (direct from battery) voltage is lower than 10 V for approx. 10 seconds.
Control effected by electronic control unit		Auto cruise control and vehicle speed limiting (SLD) control is continued.
Inspection	Service data	01: Power Supply Voltage (BATTERY)
	Electric circuit diagram	Power supply system
	Other	<ul style="list-style-type: none"> Battery (See Gr54.) Alternator (See Gr54.)

P1003: Battery Terminal (Warning lamp: 03)

Generation condition		MVCU power terminal (direct from battery) voltage is lower than 4 V for approx. 5 seconds.
Control effected by electronic control unit		Auto cruise control and vehicle speed limiting (SLD) control is continued.
Inspection	Service data	01: Power Supply Voltage (BATTERY)
	Electric circuit diagram	MVCU connector (CY31A) terminal No. 21 and No. 31 system
	Other	Battery (See Gr54.)

P1004: Main Voltage (Warning lamp: 04)

Generation condition		MVCU power terminal (starter switch ON) voltage is lower than 10 V for approx. 10 seconds.
Control effected by electronic control unit		Auto cruise control and vehicle speed limiting (SLD) control is continued.
Inspection	Service data	02: Power Supply Voltage (MAIN)
	Electric circuit diagram	Starter switch (M terminal) system
	Other	<ul style="list-style-type: none"> Battery (See Gr54.) Alternator (See Gr54.)

P1007: MVCU (Warning lamp: 07)

Generation condition		Faulty CPU (processor) in MVCU
Recoverability		System recovers (power is re-supplied to electronic control unit) if signal becomes normal when starter switch is turned OFF → ON.
Control effected by electronic control unit		<ul style="list-style-type: none"> Auto cruise control and vehicle speed limiting (SLD) control is suspended. Occurrence of trouble with vehicle speed limiting function sent through CAN bus.
Inspection	Other	Malfunction vehicle control unit proper

P1008: Vehicle Identification (Warning lamp: 08)

Generation condition		Identification start condition continued for predetermined time after starting the vehicle identification but the vehicle identification remained unidentified.
Recoverability		System recovers (power is re-supplied to electronic control unit) if signal becomes normal when starter switch is turned OFF → ON.
Control effected by electronic control unit		<ul style="list-style-type: none"> Auto cruise control and vehicle speed limiting (SLD) control is suspended. Occurrence of trouble with vehicle speed limiting function sent through CAN bus.
Inspection	Service data	13: Cruise Variation Number
	Electric circuit diagram	Write data in MVCU. (Refer to "Works Required When Replacing the Multifunction Vehicle Control Unit (MVCU)".)

P1009: Non Coding (Warning lamp: 09)

Generation condition		Data has not written in MVCU.
Recoverability		System recovers after writing data in MVCU.
Control effected by electronic control unit		<ul style="list-style-type: none"> • Auto cruise control and vehicle speed limiting (SLD) control is suspended. • Occurrence of trouble with vehicle speed limiting function sent through CAN bus.
Inspection	Other	Write data in MVCU. (Refer to “Works Required When Replacing the Multifunction Vehicle Control Unit (MVCU)”.)

P1016: Cruise Variation Identify (Warning lamp: 16)

Generation condition		The vehicle identification and auto cruise control do not match.
Recoverability		System recovers (power is re-supplied to electronic control unit) if signal becomes normal when starter switch is turned OFF → ON.
Control effected by electronic control unit		<ul style="list-style-type: none"> • Auto cruise control is suspended. • Vehicle speed limiting (SLD) control is continued.
Inspection	Service data	13: Cruise Variation Number
	Other	Write data in MVCU. (Refer to “Works Required When Replacing the Multifunction Vehicle Control Unit (MVCU)”.)

U0100: CAN Communication (Warning lamp: 05)

Generation condition		No CAN data is received from the engine electronic control unit for approx. 2 seconds.
Recoverability		System recovers (power is re-supplied to electronic control unit) if signal becomes normal when starter switch is turned OFF → ON.
Control effected by electronic control unit		<ul style="list-style-type: none"> • Auto cruise control and vehicle speed limiting (SLD) control is suspended. • Occurrence of trouble with vehicle speed limiting function sent through CAN bus.
Inspection	Electrical equipment	CAN communication system

U1013: Engine ECU Cruise Control (Warning lamp: 13)

Generation condition		<p>When either condition is met.</p> <p>① : The vehicle speeds recognized by Multifunction Vehicle Control Unit (MVCU) and by engine electronic control unit do not match for 2 seconds.</p> <p>② : Faulty auto cruise control function under the engine electronic control unit is noticed through CAN communication.</p>
Recoverability		System recovers (power is re-supplied to electronic control unit) if signal becomes normal when starter switch is turned OFF → ON.
Control effected by electronic control unit		<ul style="list-style-type: none"> • Auto cruise control is suspended. • Vehicle speed limiting (SLD) control is continued.
Inspection	Electronic control unit connector	01 : Vehicle speed sensor
	Electrical equipment	#265: Vehicle speed sensor
	Electric circuit diagram	Engine electronic control unit and Multifunction Vehicle Control Unit (MVCU) CAN communication system
	Other	Engine electronic control unit

TROUBLESHOOTING

U1031: Engine ECU SPEED Limiting (Warning lamp: 31)

Generation condition		When either condition is met. ① : The vehicle speeds recognized by Multifunction Vehicle Control Unit (MVCU) and by engine electronic control unit do not match for 2 seconds. ② : Faulty vehicle speed limiting function under the engine electronic control unit is noticed through CAN communication.
Recoverability		System recovers (power is re-supplied to electronic control unit) if signal becomes normal when starter switch is turned OFF → ON.
Control effected by electronic control unit		<ul style="list-style-type: none"> • Auto cruise control is continued. • Vehicle speed limiting (SLD) control is suspended. • Occurrence of trouble with vehicle speed limiting function sent through CAN bus.
Inspection	Electronic control unit connector	01 : Vehicle speed sensor
	Electrical equipment	#265: Vehicle speed sensor
	Electric circuit diagram	Engine electronic control unit and Multifunction Vehicle Control Unit (MVCU) CAN communication system
	Other	Engine electronic control unit

4. Multi-Use Tester Service Data

NOTE

- Both service data and actuator test results are indicated at the same time.

No.	Item	Data	Inspection condition	Criterion for normality
01	Power Supply Voltage (BATTERY)	■■■.■■ V	Starter switch in ON position	8 to 16 V
02	Power Supply Voltage (MAIN)	■■■.■■ V	Starter switch in ON position	8 to 16 V
03	Vehicle Speed	■■■■. MPH	When driving	Synchronous with speedometer
04	Vehicle Speed (Engine Electronic Control Unit)	■■■■. MPH	When driving	Synchronous with speedometer
05	Accel Pedal Position	■■■■. %	Released	0%
			Gradually pressed	Gradually rising
			Fully pressed	100%
06	Engine Speed	■■■■. rpm	Racing (with engine running)	Synchronous with tachometer
07	Engine Variation ID	■■■■.	Starter switch in ON position	200: 4M50T7 205: 4M50T8
08	Cruise Control Set Speed	■■■■. MPH	During auto cruise driving on a flat road	Equal to vehicle speed in auto cruise mode
12	Limit Vehicle Speed	■■■■. MPH	Vehicle speed limiting function activates with the accelerator pedal pressed	Around limit speed
13	Cruise Variation Number	1/2/3/4/5/6/7/8/9/ 10/11/12/NON	Starter switch in ON position	Recognized as "2" (with auxiliary brake non-linked cruise function) through the information record feature of MVCU
21	Neutral SW	Neutral/shift	Transmission in neutral	Neutral
			Transmission in other gear than neutral	Shift
24	Brake SW 1	ON/OFF	Brake pedal pressed	ON
			Brake pedal released	OFF
25	Brake SW 2	ON/OFF	Brake pedal pressed	ON
			Brake pedal released	OFF
29	Cruise Main SW	ON/OFF	Cruise control main switch ON	ON
			Cruise control main switch OFF	OFF
30	Cruise Set SW	ON/OFF	Set and resume switch SET	ON
			Set and resume switch OFF	OFF
31	Cruise Resume SW	ON/OFF	Set and resume switch RESUME	ON
			Set and resume switch OFF	OFF
34	Diagnosis SW	ON/OFF	Diagnosis switch ON (fuse connected)	ON
			Diagnosis switch OFF (fuse disconnected)	OFF
35	Memory Clear SW	ON/OFF	Memory clear switch ON (fuse connected)	ON
			Memory clear switch OFF (fuse disconnected)	OFF

TROUBLESHOOTING

No.	Item	Data	Inspection condition	Criterion for normality
41	Cruise Lamp	ON/OFF	Auto cruise mode	ON
			Normal driving	OFF
			[Actuator test] 51: Cruise Lamp ON 52: Cruise Lamp OFF	
43	System Warning Lamp	ON/OFF	Starter switch in ON position (engine not started)	ON for some seconds
			[Actuator test] 55: System Warning Lamp ON 56: System Warning Lamp OFF	

5. Actuator Tests Performed Using Multi-Use Tester

NOTE

- Both service data and actuator test results are indicated at the same time.

No.	Item	Description	Check method
51	Cruise Lamp ON	Auto cruise indicator lamp drive signal	Lighting status of auto cruise indicator lamp [Service data] 41: Cruise Lamp
52	Cruise Lamp OFF		
55	System Warning Lamp ON	Vehicle control warning lamp drive signal	Lighting status of vehicle control warning lamp [Service data] 43: System Warning Lamp
56	System Warning Lamp OFF		

6. Works Required When Replacing the Multifunction Vehicle Control Unit (MVCU)

- When replacing the MVCU with a new one, it is necessary to write the vehicle specification identification data and necessary control parameters for softwares in the new MVCU. Otherwise the system cannot operate correctly, resulting in faulty system.
- For data writing operation, ask your nearest STERLING TRUCKS dealer or STERLING TRUCKS CORPORATION.

7. Inspections Performed at Electronic Control Unit Connectors

- These inspections aid troubleshooting by enabling you to check whether electronic control unit signals are being correctly transmitted via the vehicle harness and connectors.

The white-on-black numbers (01, 02 and so on) correspond to the similarly printed reference numbers in section “3. Inspection Based on Diagnosis Codes”.

7.1 Electronic control unit connector terminal arrangement

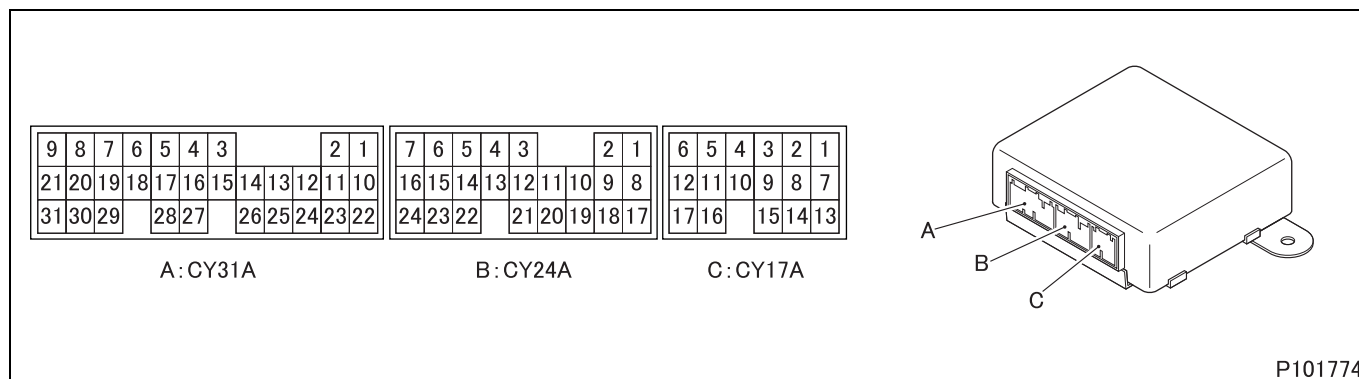

7.2 Inspection procedure

CAUTION

- Depending on check items, checking is performed with connector disconnected or left connected.
- Be sure to not touch any other connector terminal than involved in the check. Use extra care so that connector terminals are not shorted by the tester.

Check item	Check method
<p>01</p> <p>Vehicle speed sensor signal voltage</p>	<p>[Conditions]</p> <ul style="list-style-type: none"> • Starter switch is in ON position. • Vehicle-side harness is left connected (checked from behind the connector.) • Wheels are slowly rotated using chassis dynamo or the like. <p>[Criteria]</p> <p>Between terminals (+) - (-): A23-chassis grounding</p> <ul style="list-style-type: none"> • High pulse voltage: Approx. 8 ± 1 V • Low pulse voltage: 0.5 V or less
<p>02</p> <p>Stop lamp switch continuity</p>	<p><Switch (H1)></p> <p>[Conditions]</p> <ul style="list-style-type: none"> • Starter switch in ON position. • Cruise control main switch in ON position. • Connector disconnected; check at vehicle-side connector <p>[Criteria]</p> <p>Between terminals: B12-chassis grounding</p> <ul style="list-style-type: none"> • When brake pedal pressed: Continuity established • When brake pedal released: No continuity <p><Switch (H2)></p> <p>[Conditions]</p> <ul style="list-style-type: none"> • Starter switch in OFF position. • Connector disconnected; check at vehicle-side connector <p>[Criteria]</p> <p>Between terminals: B13-chassis grounding</p> <ul style="list-style-type: none"> • When brake pedal pressed: Continuity established • When brake pedal released: No continuity

INSPECTION OF ELECTRICAL EQUIPMENT

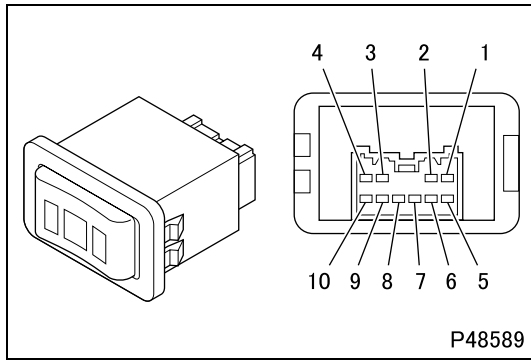

#007 Cruise control main switch inspection

Switch position	Terminal continuity	Operational illumination	Night illumination
ON	1 - 7, 5 - 6	(+) 9 - 3 (-)	(+) 2 - 3 (-)
N (Neutral)	5 - 6	-	
OFF	-	-	

- Replace the switch if found abnormality.

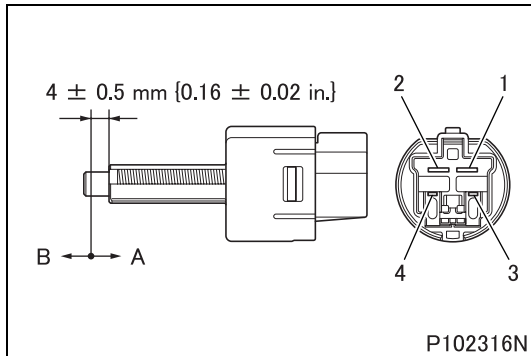

#042 Stop lamp switch

Switch position	Terminal continuity
A	3 - 4
B	1 - 2

- Replace the switch if found abnormality.

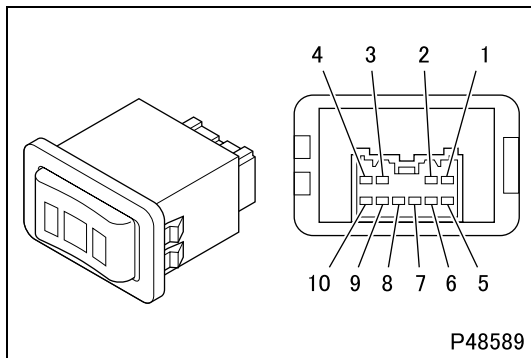

#099 Set and resume switch inspection

Switch position	Terminal continuity	Night illumination
SET	1 - 7	(+) 2 - 3 (-)
N (Neutral)	1 - 8	
RESUME	-	

- Replace the switch if found abnormality.

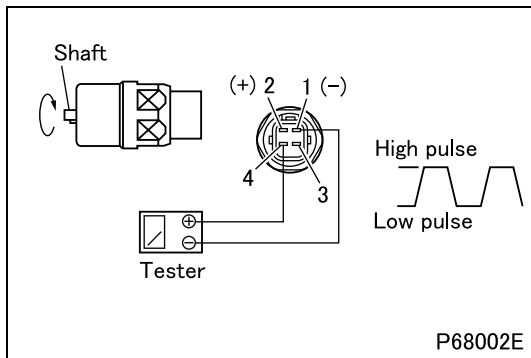

#265 Vehicle speed sensor inspection

- Slowly rotate the shaft of the vehicle speed sensor with battery voltage applied between terminals 1 and 2 of the sensor.
- Measure maximum voltage (high pulse voltage) and minimum voltage (low pulse voltage) appearing between terminals 1 and 4 of the sensor.

Standard value	Low pulse voltage	0.5 V or less
	High pulse voltage	8 ± 1 V

- If the measurements deviate from the specified standard values, replace the sensor.

M E M O

INSTALLED LOCATIONS OF PARTS

A01 to 14

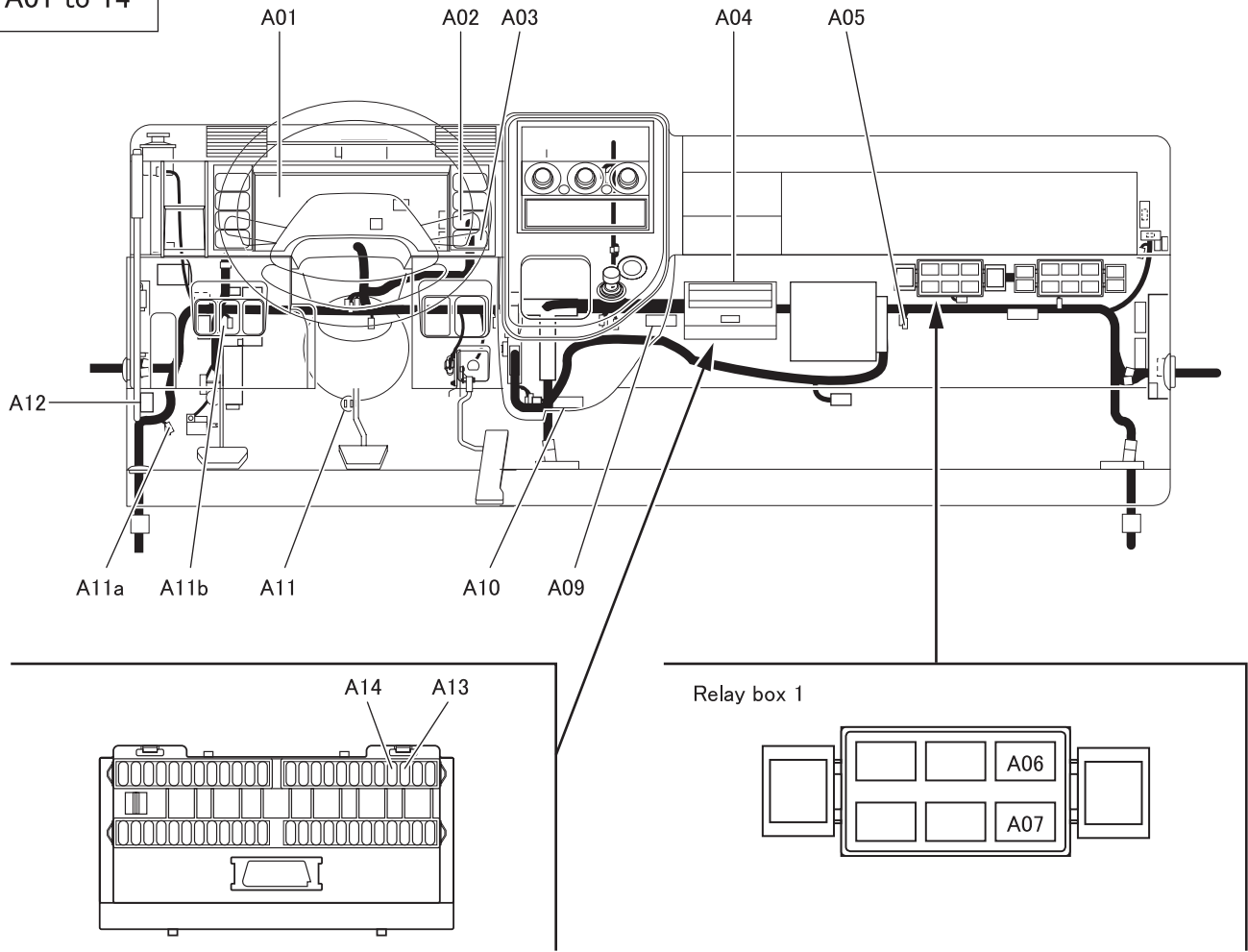

- A01 Meter cluster
- A02 Cruise control main switch
- A03 Set and resume switch
- A04 Fuse box
- A05 Diode
- A06 Stop lamp relay
- A07 Cruise control main relay
- A08 Starter switch
- A09 Joint connector (J/C-1)
- A10 Joint connector (J/C-M1)
- A11 Stop lamp switch
- A11a Joint connector(J/C-040)
- A11b Joint connector(J/C-040)<A/T>
- A12 Multi-Use Tester connector
- A13 Memory clear switch
- A14 Diagnosis switch

A/T : Automatic transmission
 J/C : Joint connector
 Indicate by connector type [].

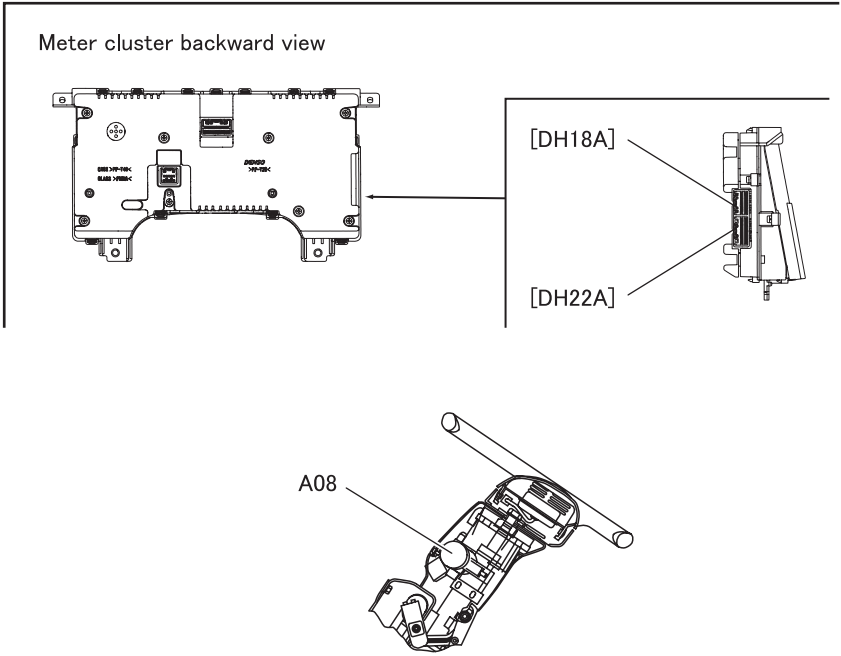

A21 to 24

<Inside of instrument panel>

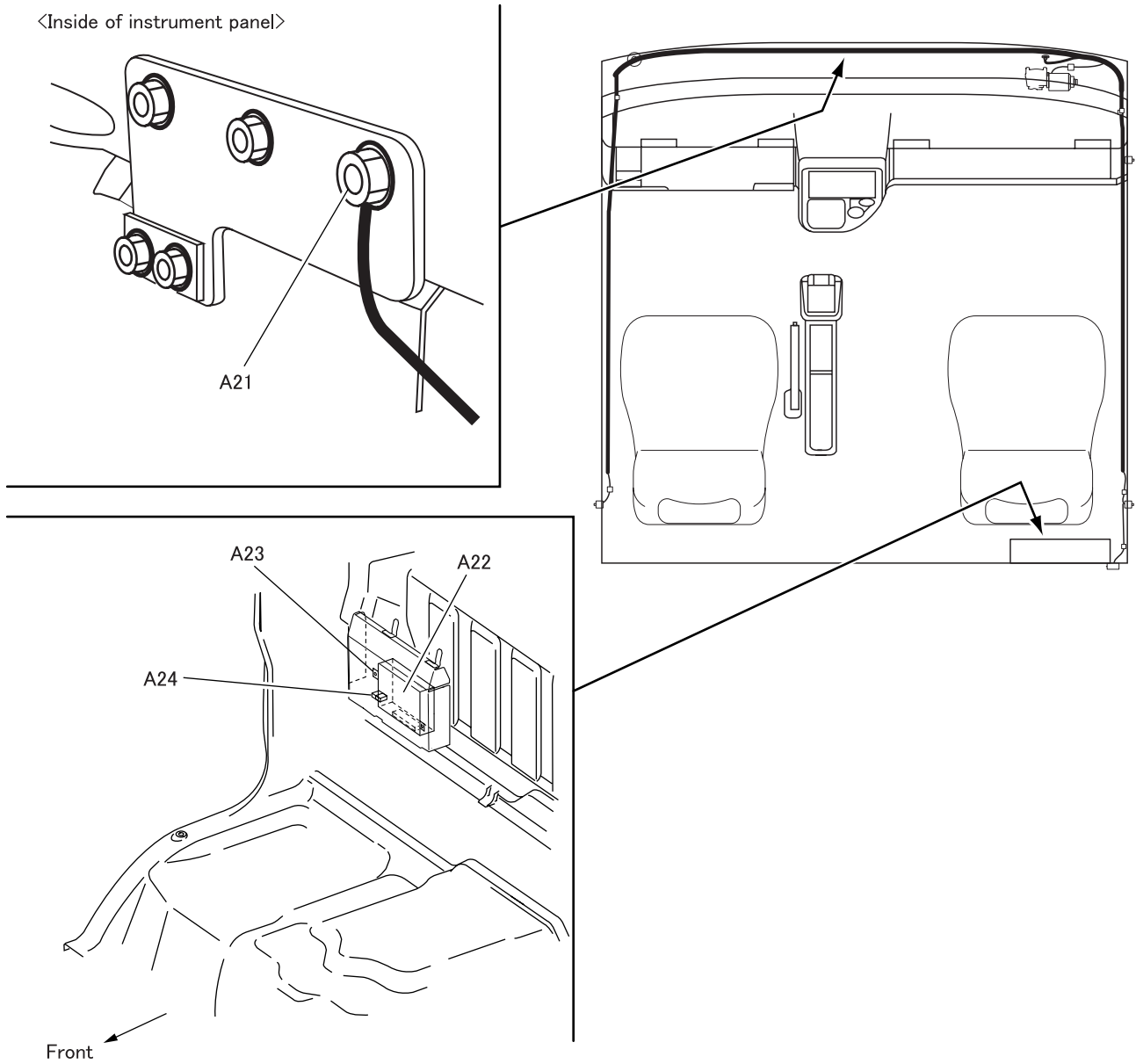

- A21 Ground
- A22 MVCU
- A23 Ground
- A24 Resistor unit

MVCU : Multifunction vehicle control unit

INSTALLED LOCATIONS OF PARTS

B01 to 07

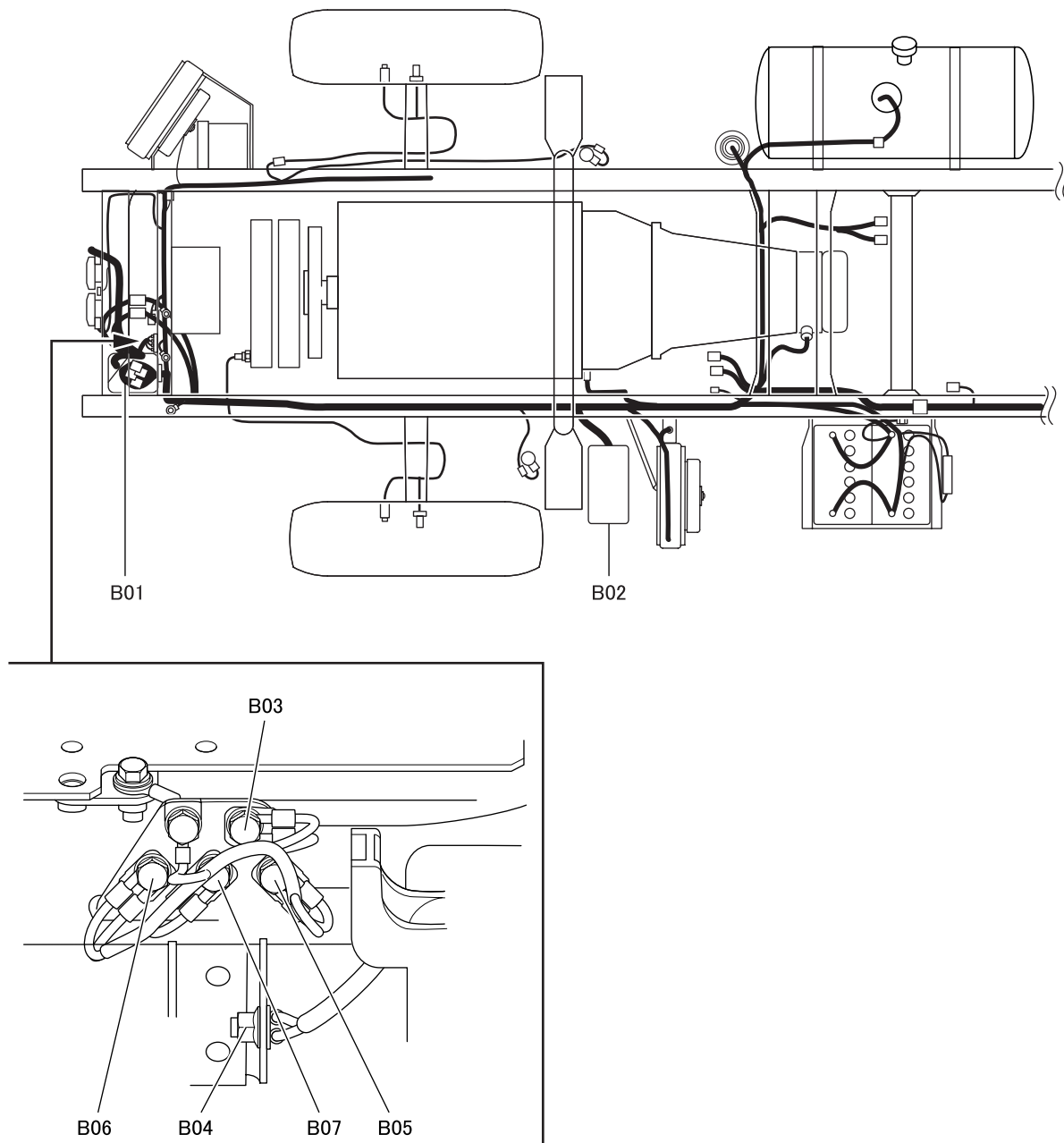

- B01 Connection of chassis harness and cab harness
- B02 High-current fuse box
- B03 Ground
- B04 Ground
- B05 Ground
- B06 Ground
- B07 Ground

C01

<Automatic transmission>

Left side view

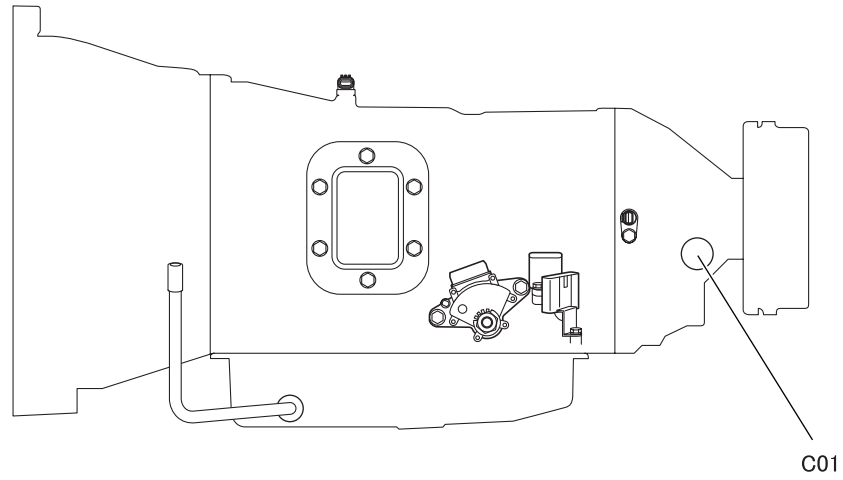

<Manual transmission>

Left side view

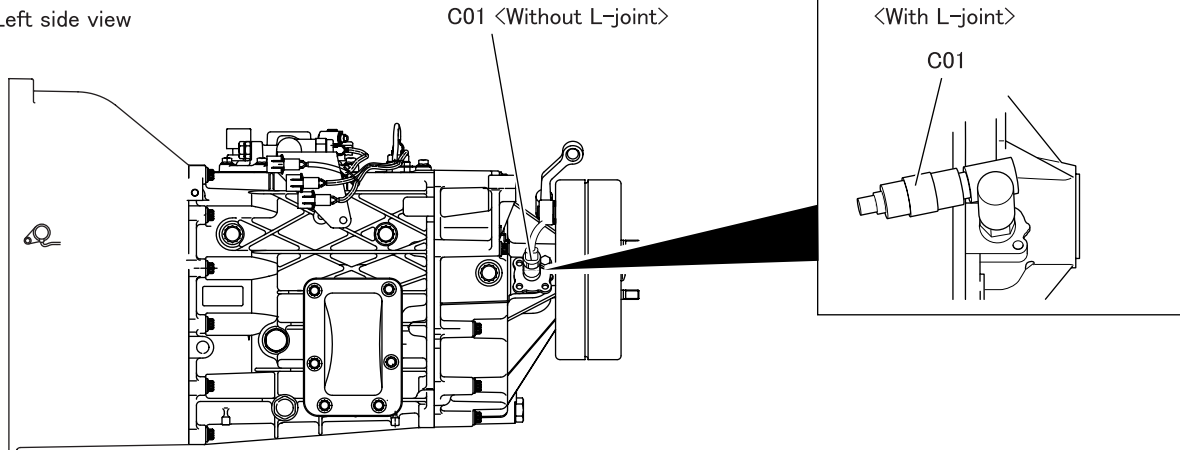

C01 Vehicle speed sensor

ELECTRIC CIRCUIT DIAGRAM

