INDEX

SPECIFICATIONS	31-2
TROUBLESHOOTING	31-3
WHEEL AND TIRE	31-4

SPECIFICATIONS

Tire size	Wheel type
215/85R16	16 × 6K-127
215/75R17.5	17.5 × 6.00-127

- Tire pressures specified for each tire size are shown on the tire pressure label.

Symptoms		Tire tread wear										Reference Gr	
		Both shoulders worn	Center worn	Outside worn	Inside worn	Worn in feather pattern from outside in	Worn in feather pattern from inside out	Worn in wave pattern	Worn in concave (one spot or more)	Worn in pit over the entire periphery	Worn in serration		
Probable causes													
Overload		O											
Tire pressure	Too low	O							O	O	O	O	
	Too high		O										
Wheel alignment	Toe-in	Excessive			O		O						
		Insufficient				O							
	Camber	Excessive			O								
		Insufficient				O							
	Excessive toe-out					O		O					
	Multiple misalignment		O		O	O	O	O	O	O	O		
Knuckle arm bent				O	O	O	O						
Left and right tie-rods different in length						O							
Wheels out of balance									O	O	O	O	
Wheel bearing loose									O	O	O	O	
Ball joint loose										O			
Tie-rod end loose										O			
Brake drum eccentrically mounted <Drum brake>										O	O		
Axle bent <Rigid axle suspension>									O	O			
Left and right wheels steered at improper angles											O		
Hard acceleration, braking, or steering											O		
Specific road surface conditions				O	O								

WHEEL AND TIRE

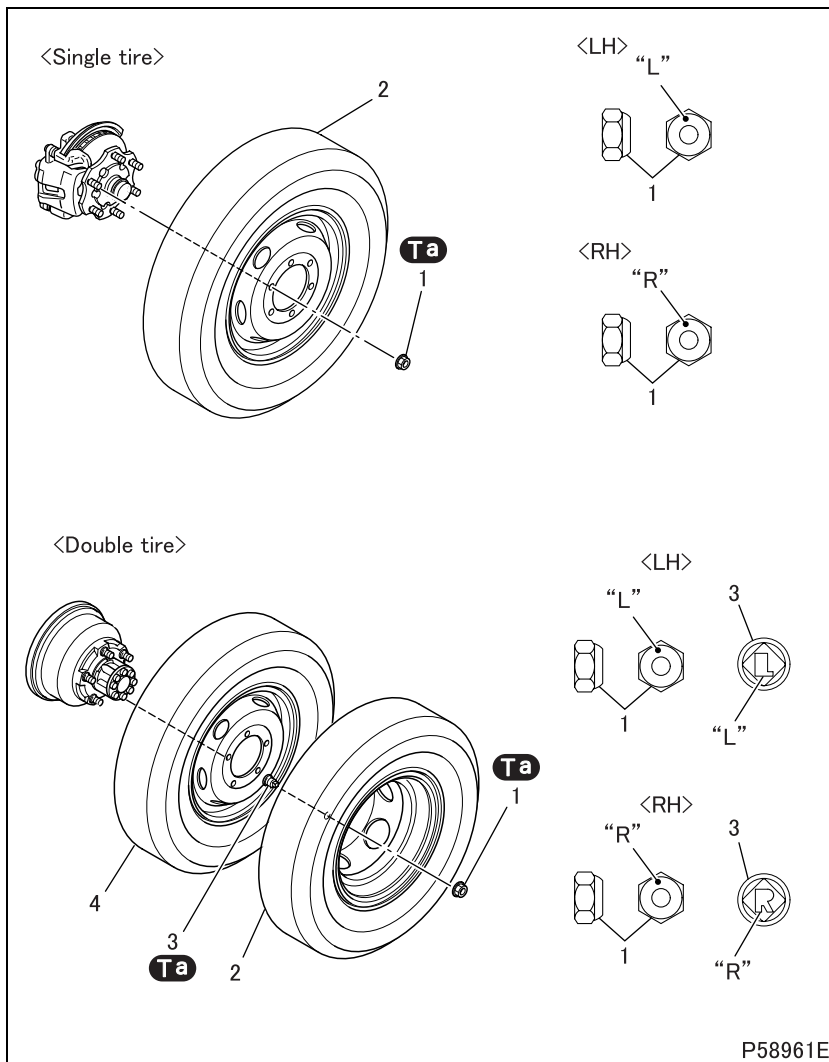

CAUTION

- Use right-hand threaded wheel nuts marked “R” for right side wheels and left-hand threaded wheel nuts marked “L” for left side wheels.

● Removal sequence

- 1 Wheel nut <Single tire>
Wheel nut (outer) <Double tire>
- 2 Tire (See later section.)
- 3 Wheel nut (inner) <Double tire>
- 4 Tire <Double tire>
(See later section.)

● Installation sequence

Follow the removal sequence in reverse.

CAUTION

- The wheel nuts are designed to be tightened without any coating of grease. Never grease the wheel nuts. Even if tightened to the specified torques, greased wheel nuts can become loose.

Service standards (Unit: mm {in.})

Location	Maintenance item	Standard value	Limit	Remedy
2, 4	Tire lateral runout (sideway deflection)	3.5 {0.14} or less	–	Correct or re-place

Tightening torque (Unit: N·m {ft.lbs, kgf·m})

Mark	Parts to be tightened		Tightening torque	Remarks
Ta	Wheel nut	16 × 6K-127 16 × 6K-135 17.5 × 6.00-127	490 ± 49 {360 ± 36, 50 ± 5.0}	–

◆ Inspection procedure ◆

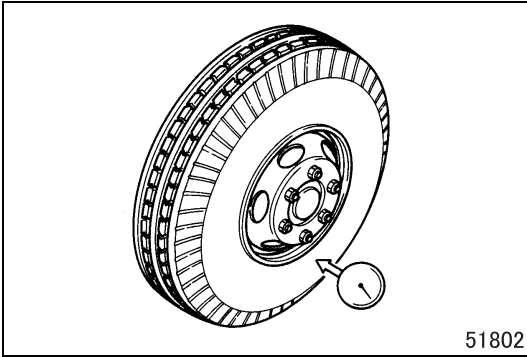

■ Inspection: Tire

- Measure the tire for lateral runout (sideway deflection).
- If the measured value is equal to or exceeds the standard value, correct as follows.

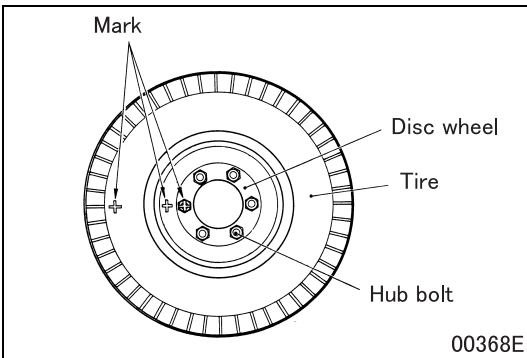

■ Correction: Tire

- Mark the tire, disc wheel, and one of the hub bolts in the illustrated locations.
- Remove the tire from the disc wheel.

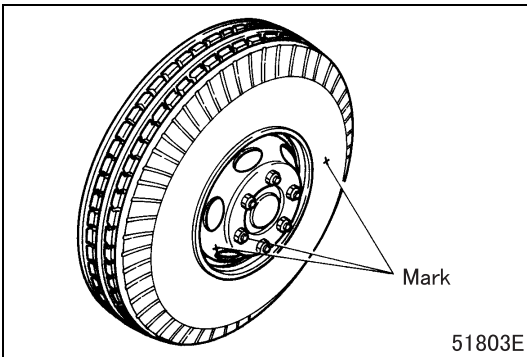

- Measure the disc wheel for lateral runout.
- If the disc wheel's maximum runout is located near the mark on the wheel, install the tire such that the mark on the tire is 180° away from the mark on the disc wheel.
- Measure the tire again for lateral runout.
- If the measured value still does not conform to the standard value, replace the tire.

WHEEL AND TIRE

◆ Installation procedure ◆

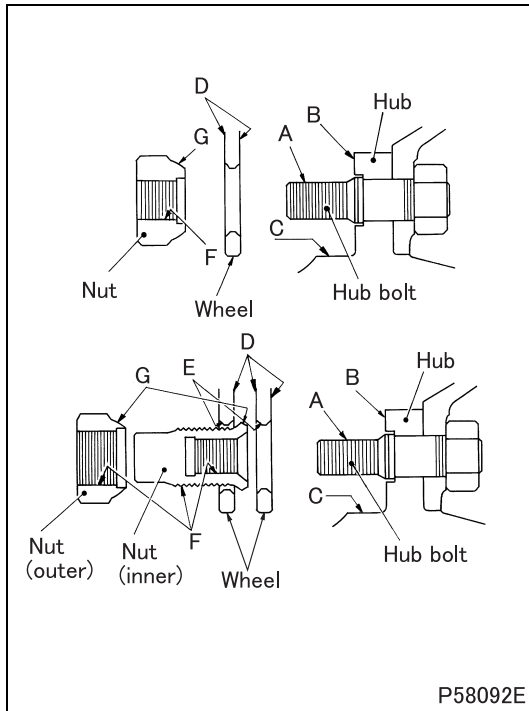

■ Installation: Tire

- To prevent hardware and parts from becoming loose and/or damaged, thoroughly clean the following areas, removing rust, dirt, paint and foreign matter, before installing the tire.

- A:** Threaded portion of hub bolt
- B:** Wheel mounting surface of hub
- C:** Wheel alignment area of hub
- D:** Mating surfaces of disc wheel
- E:** Wheel nut mounting surface of disc wheel
- F:** Threaded portion of wheel nut
- G:** Spherical portion of wheel nut

Tire

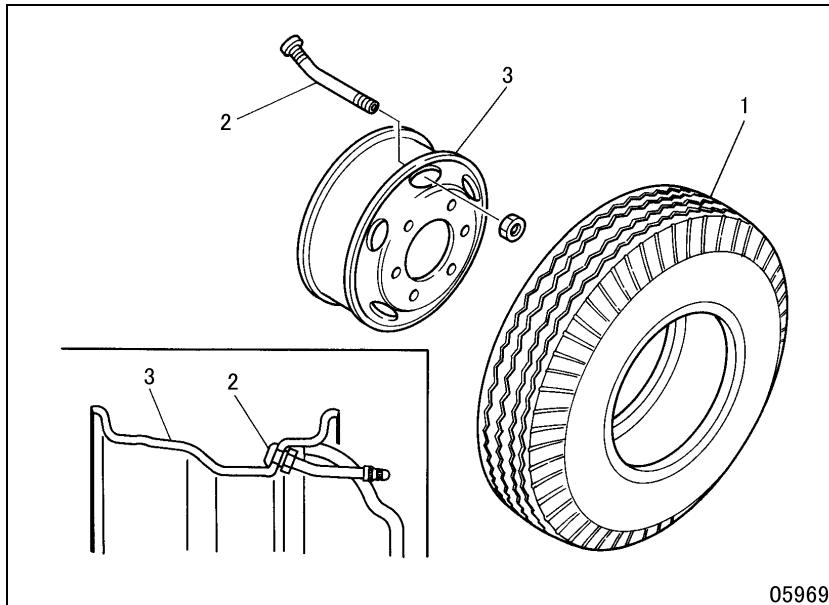

● Disassembly sequence

- 1 Tire
- 2 Air valve
- 3 Disc wheel

● Assembly sequence

Follow the disassembly sequence in reverse.

Service standards (Unit: mm {in.})

Location	Maintenance item		Standard value	Limit	Remedy
–	Tire assembly static unbalance tolerance		70 g {2.47 oz} or less	–	Correct
3	Disc wheel	16 × 6K-127	Flatness (at hub surface)	0.3 {0.012} or less	–
		16 × 6K-135			
		17.5 × 6.00-127			
		Lateral runout (sideway deflection)	1.5 {0.059} or less	–	Replace
		Radial runout (vertical deflection)	1.5 {0.059} or less	–	

◆ Inspection procedure ◆

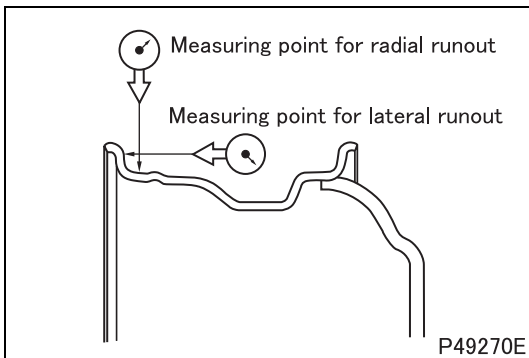
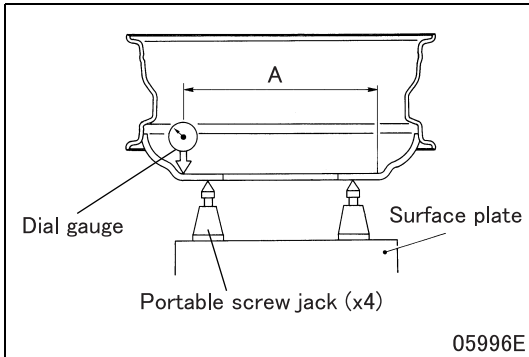

◆ Installation procedure ◆

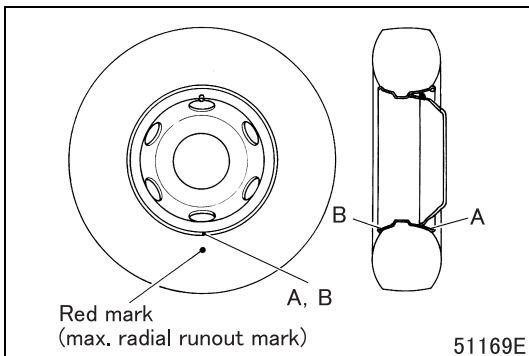
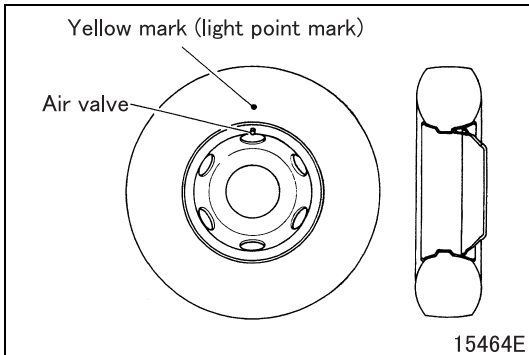

■ Inspection: Disc wheel

(1) Flatness

- Using a dial gauge, measure the disc wheel for flatness (difference between the maximum and minimum values measured) at specified distance **A** from the center of the wheel, at 5 locations for 5-stud units and 6 locations for 6-stud units that are equally divided around the specified circumference on the wheel.

A: $\phi 170$ mm, 270 mm {6.69, 10.6 in.} 16 \times 6K-127

16 \times 6K-135

$\phi 175$ mm, 275 mm {6.89, 10.8 in.} 17.5 \times 6.00-127

- If the measured flatness is equal to or exceeds the specified value, replace the disc wheel.

(2) Runout

- If the measured value is equal to or exceeds the standard value, replace the disc wheel.

■ Installation: Tire

<Tire with no red mark>

- Install the tire such that the yellow mark (light point mark) on the tire is aligned with the air valve on the disc wheel.

<Tire with red mark>

- Install the tire such that the red mark (max. radial runout mark) on the tire is aligned with mark **A** or **B** on the disc wheel.

A: Front face of disc wheel <All wheels except 17.5-inch wheel>

B: Back face of disc wheel <17.5-inch wheel>

WHEEL AND TIRE

◆ Installation procedure ◆

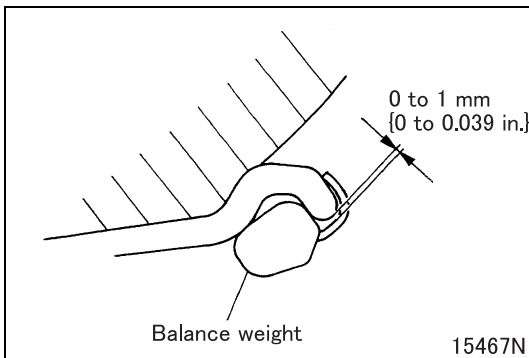
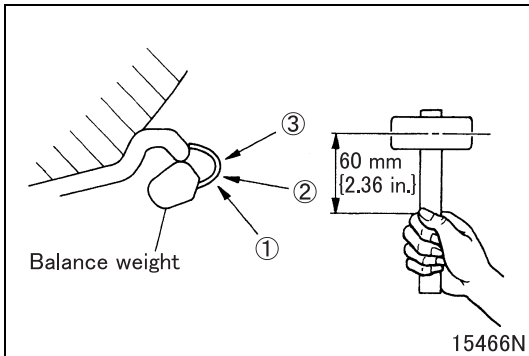
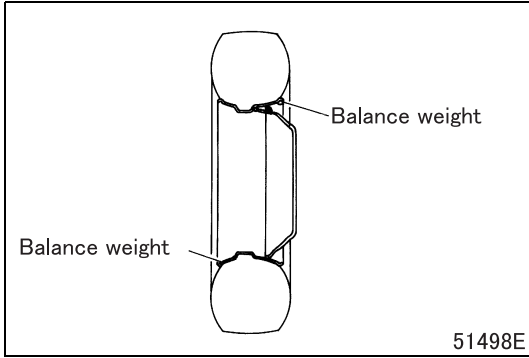

■ Installation: Balance weight

- Install balance weights onto the front and back sides of the disc of the tires on front axle. Ensure that the static unbalance of the tire being balanced remains within the standard value.
- Use a 1-pound resin hammer to drive balance weights into position.
- To install a balance weight, tap the clip of the weight in the center at 1, 2 and 3 in that order.
- Leave a clearance of approx. 0 to 1 mm {0 to 0.039 in.} between the clip and the disc wheel. Ensure that the balance weight is not loose after installation.
- Do not use a balance weight that has been improperly tapped or dropped to the floor during installation attempt.
- When 2 weights are being installed, these weights should be as much equal to each other as possible in weight. Also remember that the center point between the weights will become the support point for a balancer.