

---

# INDEX

<b>SPECIFICATIONS .....</b>	<b>55-2</b>
<b>STRUCTURE AND OPERATION</b>	
1. Heater .....	55-4
2. Air Conditioner.....	55-5
3. Air Duct .....	55-6
4. Heater Control .....	55-7
<b>TROUBLESHOOTING .....</b>	<b>55-10</b>
<b>ON-VEHICLE INSPECTION AND ADJUSTMENT</b>	
1. Recovery of Refrigerant .....	55-12
2. Recharging the System with Refrigerant .....	55-13
3. Checking Refrigerant Charge Level .....	55-15
4. Adding Refrigerant .....	55-16
<b>CONNECTING AIR CONDITIONER PIPING .....</b>	<b>55-17</b>
<b>COMPRESSOR .....</b>	<b>55-18</b>
<b>CONDENSER, RECEIVER.....</b>	<b>55-20</b>
<b>HEATER CONTROL .....</b>	<b>55-22</b>
<b>AIR DUCT.....</b>	<b>55-26</b>
<b>HEATER AND COOLING UNIT, BLOWER .....</b>	<b>55-28</b>

# SPECIFICATIONS

## <Without Air Conditioner>

Item		Specifications	
System	Damper change-over system	Mode selection	Manual cable type
		Air mixing	Manual cable type
		Fresh/recirculation changeover	Servomotor
	Servomotor rated voltage	V	12
Heater unit	Manufacturer	MITSUBISHI HEAVY INDUSTRIES, LTD.	
	Heating capacity W {kcal/h}	4370 ± 437 {3758 ± 376}	
	Temperature control system	Air mixing type	
Blower	Manufacturer	MITSUBISHI HEAVY INDUSTRIES, LTD.	
	Blower motor voltage	V	12

## &lt;Air Conditioner&gt;

Item		Specifications		
System	Type	Manual type air conditioner		
	Refrigerant	Type	HFC134a	
		Charged quantity g {oz}	650 {22.9}	
	Damper change-over system	Mode selection	Manual cable type	
		Air mixing	Manual cable type	
		Fresh/recirculation changeover	Servomotor	
Servomotor rated voltage	V	12		
Heater and cooling unit	Manufacturer	MITSUBISHI HEAVY INDUSTRIES, LTD.		
	Heating capacity W {kcal/h}	4370 ± 437 {3758 ± 376}		
	Cooling capacity W {kcal/h}	4340 ± 434 {3732 ± 373}		
	Temperature control system	Air mixing type		
Blower	Manufacturer	MITSUBISHI HEAVY INDUSTRIES, LTD.		
	Blower motor voltage	V	12	
Compressor	Manufacturer	MITSUBISHI HEAVY INDUSTRIES, LTD.		
	Model	MSC90TA		
	Discharge	cm <sup>3</sup> {mL}/1 rotation	90 {90}	
	Lubricant	Type	SUN PAG56	
Quantity cm <sup>3</sup> {cu.in.}		140 <sup>+20</sup> / <sub>0</sub> {8.54 <sup>+1.22</sup> / <sub>0</sub> }		
Condenser	Manufacturer	MITSUBISHI HEAVY INDUSTRIES, LTD.		
	Rated current	A	Wide cab	7 <sup>+1.0</sup> / <sub>-1.5</sub>
		Standard wide cab	9.5 <sup>+1.8</sup> / <sub>-2.0</sub>	
Receiver	Manufacturer	MITSUBISHI HEAVY INDUSTRIES, LTD.		
	Capacity	cm <sup>3</sup> {cu.in.}	350 {21.4}	

# STRUCTURE AND OPERATION

## 1. Heater

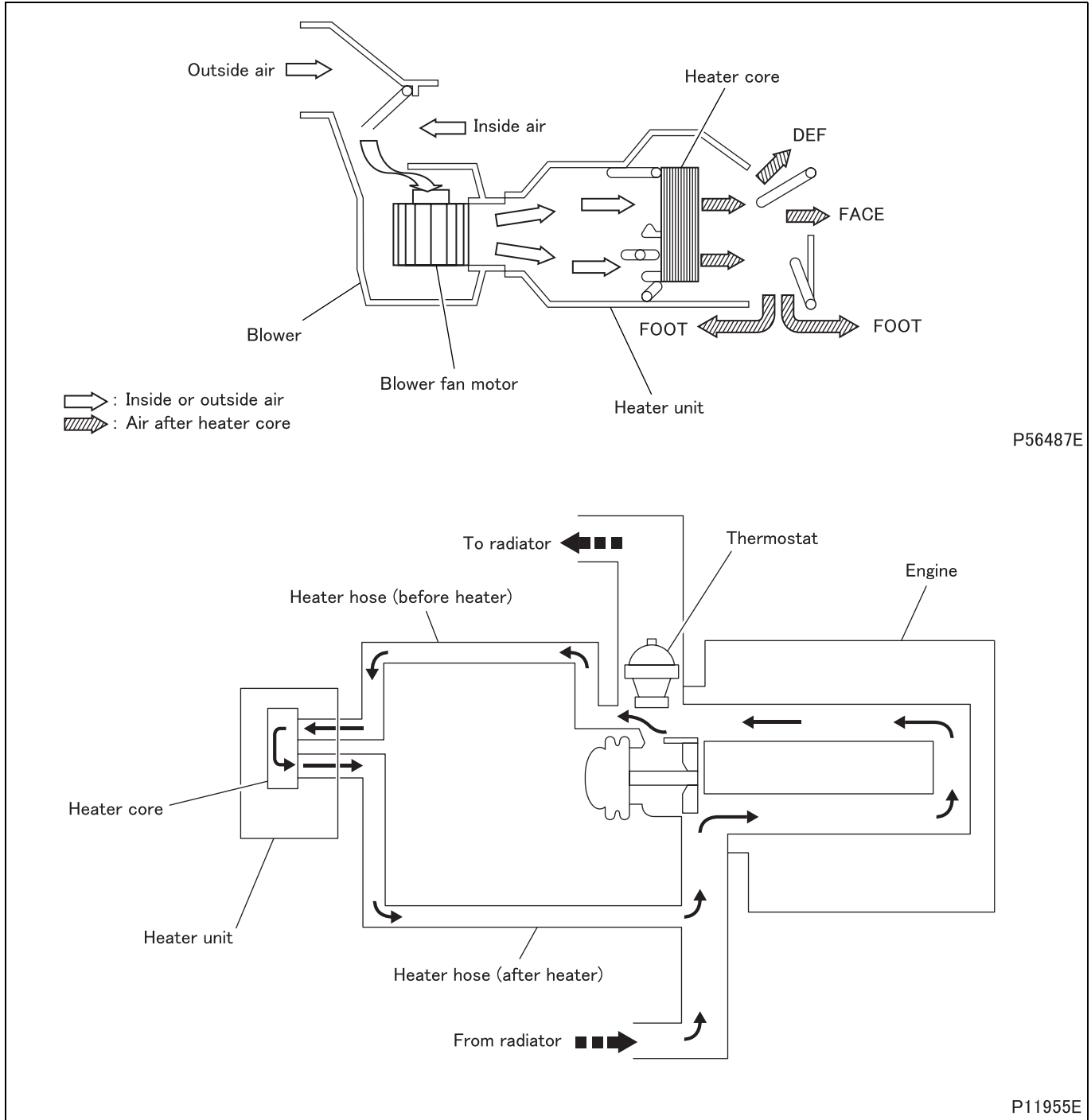

- The blower sends air to the heater unit, where the air is heated by the heater core (heat exchanger). The warmed-up air is then sent through the ducts into the cab.
- Water (engine coolant) warmed up by the heat from the engine circulates permanently through the heater core, irrespective of whether the thermostat is open or closed.

## 2. Front Air Conditioner

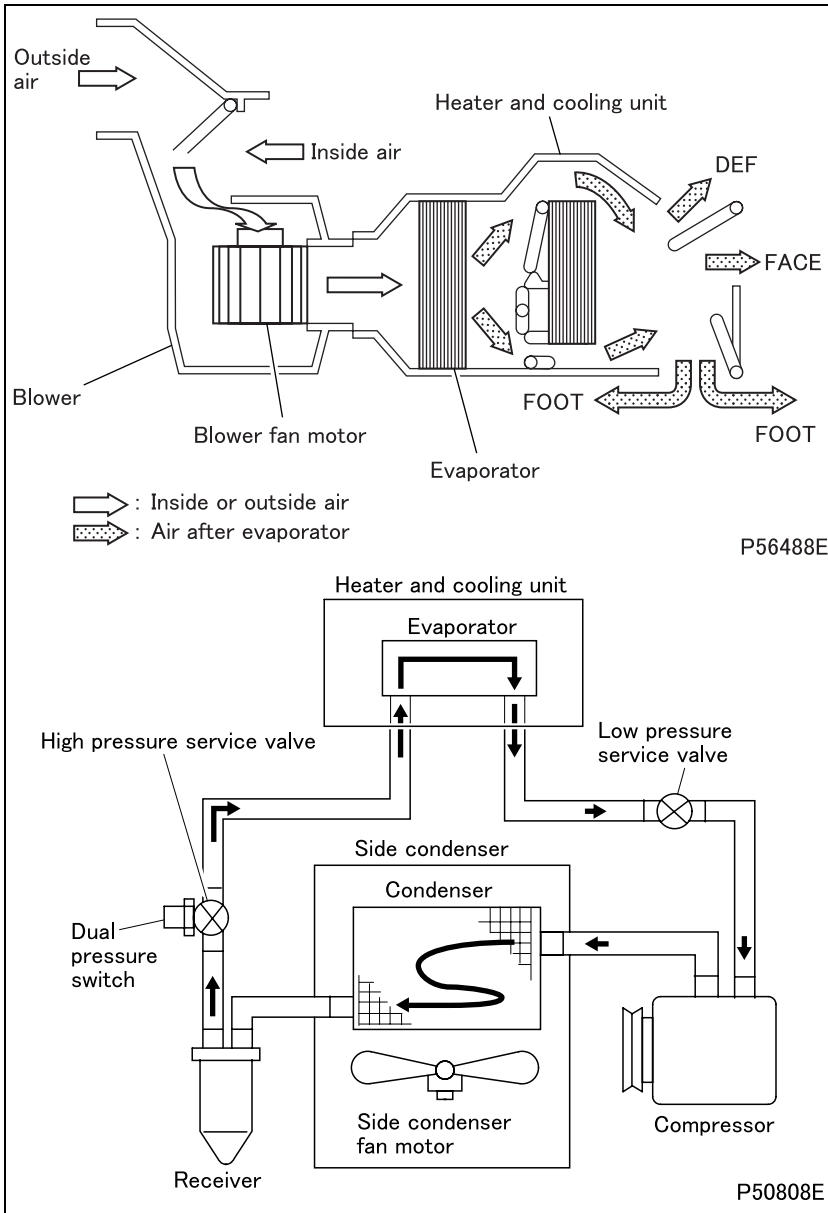

- The blower sends air to the heater and cooling unit, where the air is cooled by the evaporator. The cooled air is then sent through the ducts into the cab.
- Refrigerant in gas form is compressed by the compressor. The compressed gas is then sent to the side condenser, where it is cooled by outside air and condenses into liquid form.
- The liquid refrigerant is sprayed into the evaporator, where it quickly evaporates into gas form while at the same time absorbing heat from the surrounding air.
- The refrigerant in gas form is again sent to the compressor and is compressed there.
- When the refrigerant pressure in the high pressure line reaches the specified limit, the dual pressure switch senses this and turns itself OFF. At the same time, the magnet clutch is turned OFF.

# STRUCTURE AND OPERATION

## 3. Air Duct

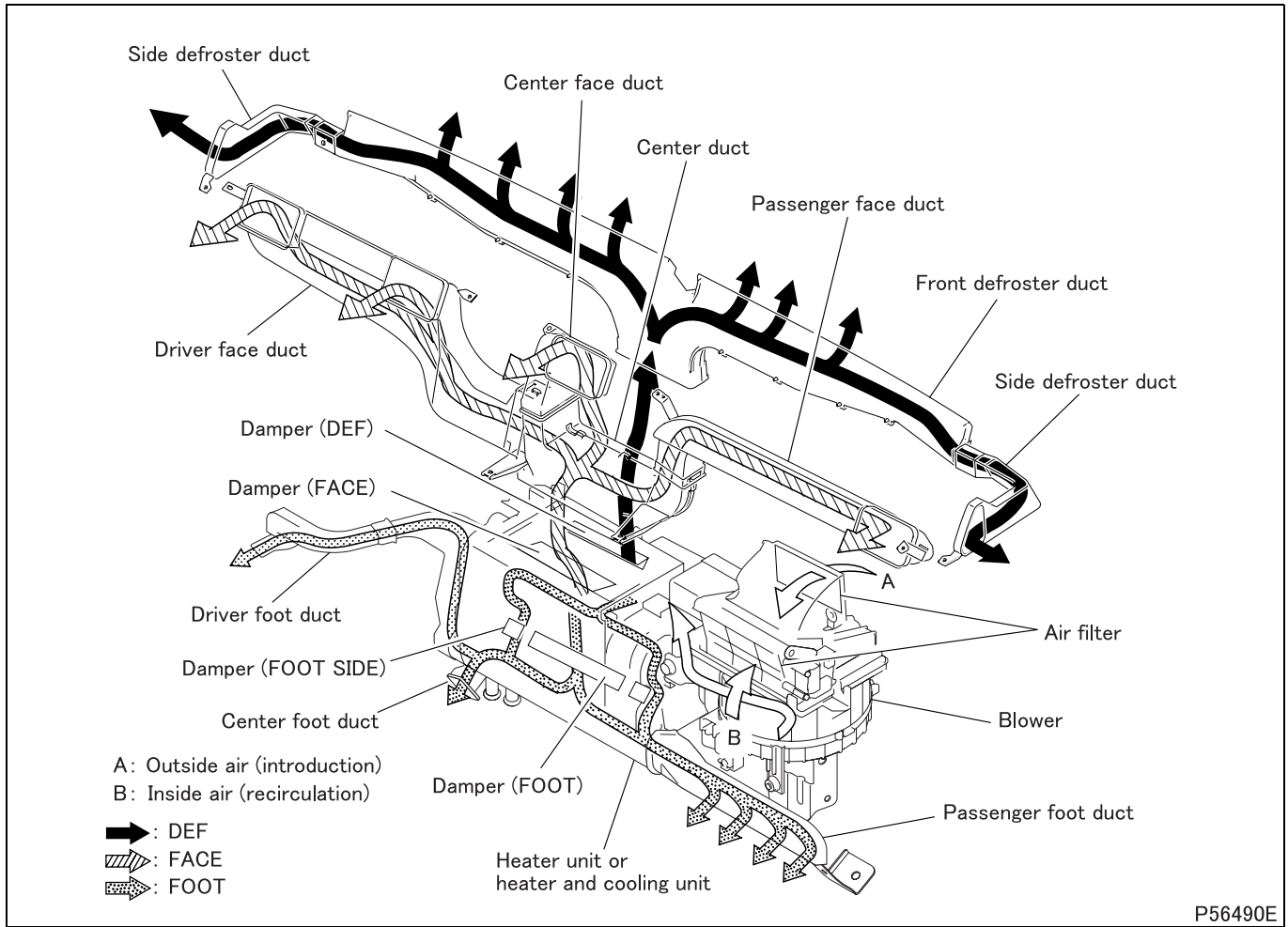

- The blower sends outside air **A** or inside air **B** through the heater unit or heater and cooling unit to the ducts. The flow of air is dependent on the open/closed positions of the various dampers.

### 4. Heater Control

#### 4.1 Mode selection

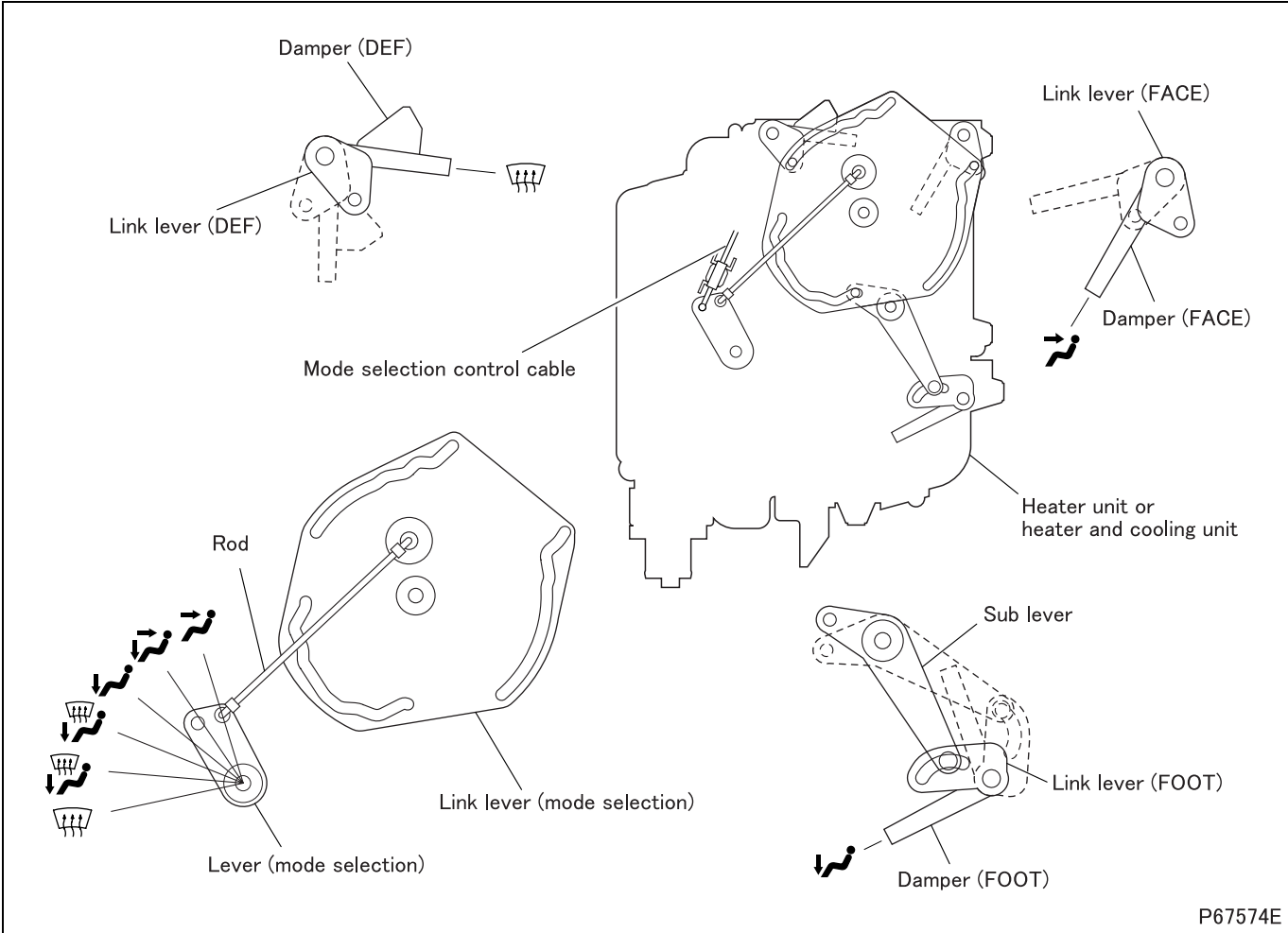

P67574E

# STRUCTURE AND OPERATION

## 4.2 Air mix selection <Air conditioner>

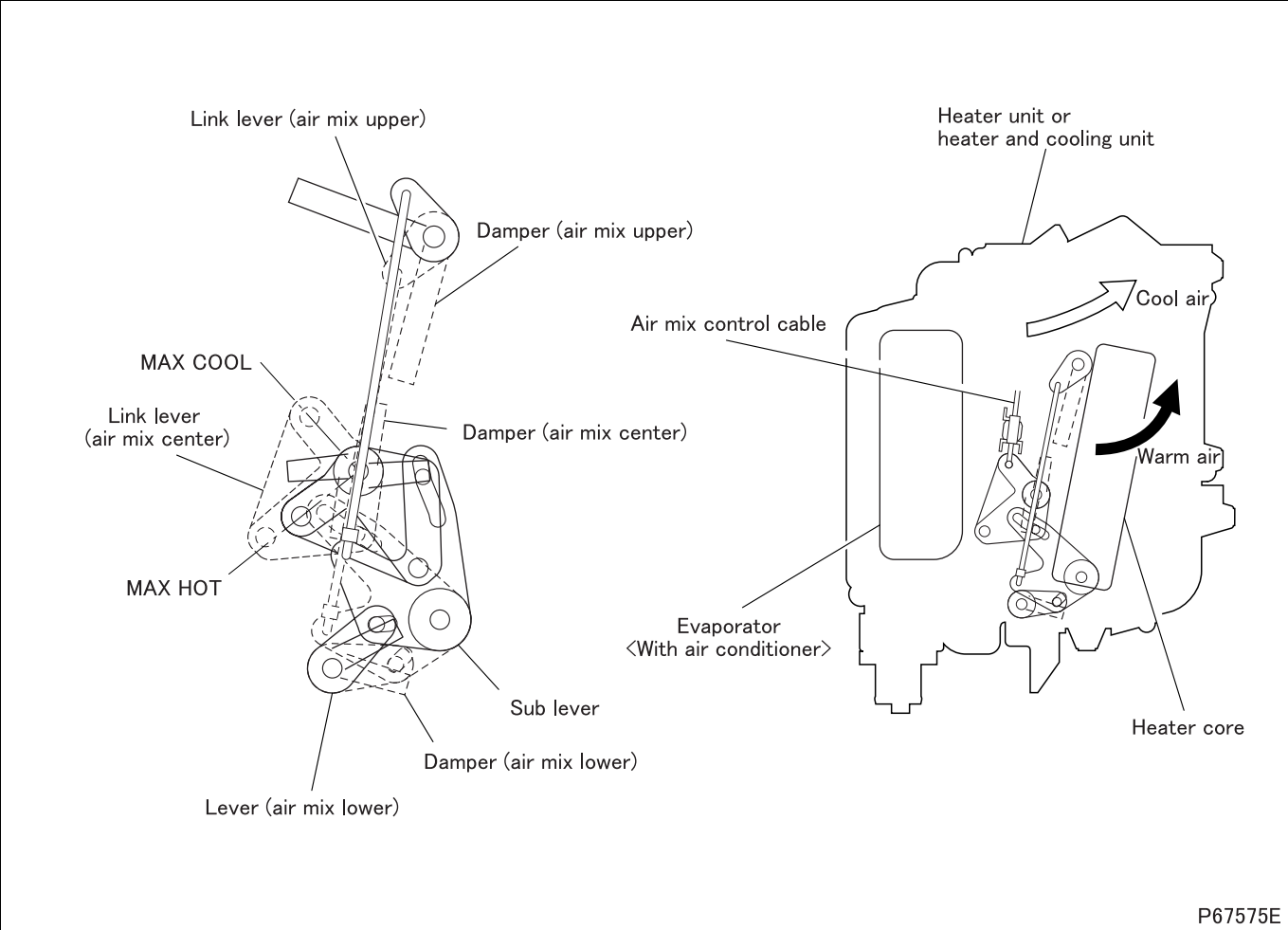



### 4.3 Fresh/recirculation changeover

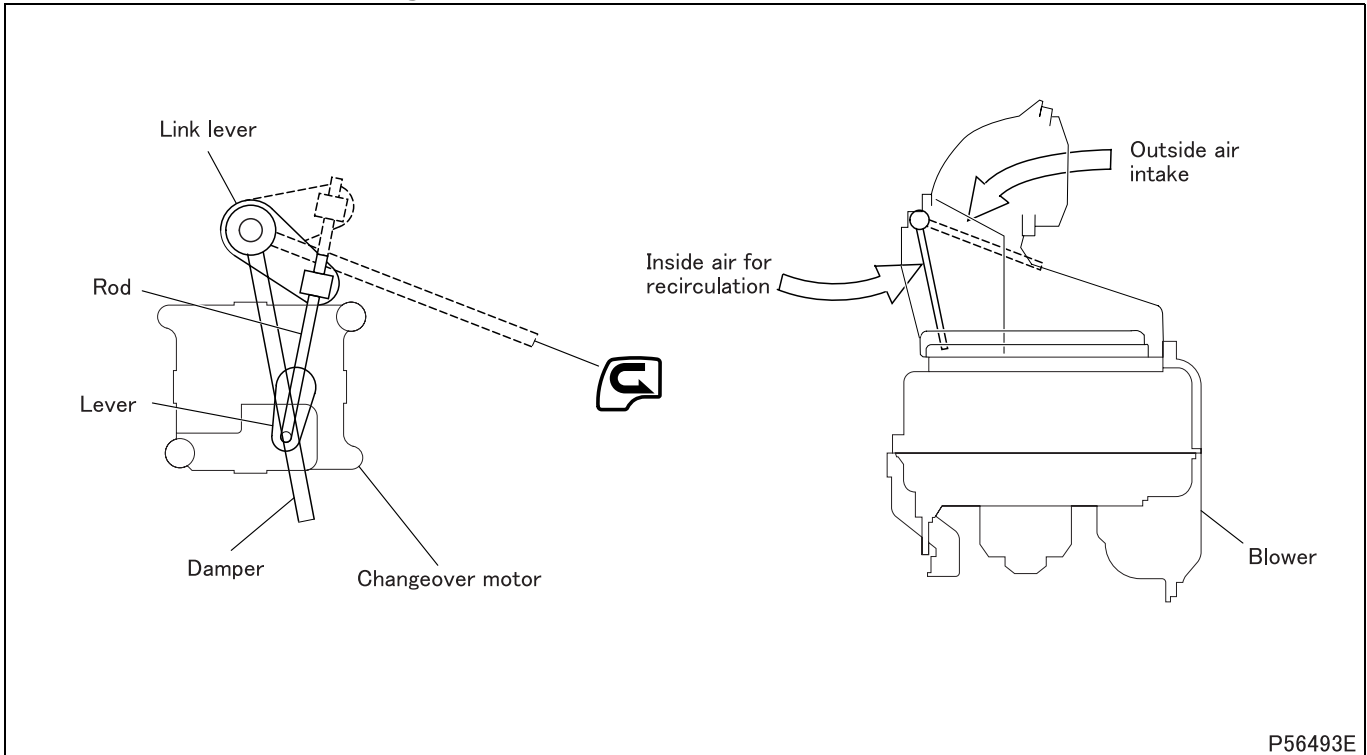

P56493E

- The fresh/recirculation changeover damper is operated by means of motor.

# TROUBLESHOOTING

## Heater, Front Air Conditioner

Symptoms	Possible causes								Reference Gr	
	No air from vents	Poor cooling	Poor heating	No mode selection	Draft from vents	No temperature setting	No ventilation/recirculation selection	Air volume from vents unstable		Controls require too much effort
Blower motor coil open, shorted	O									Gr54
Blower motor relay contacts stuck closed, coil open, shorted	O									
Blower resistor malfunction <A/C>							O			
Compressor seized, malfunction <A/C>		O								
Refrigerant charge low <A/C>		O					O			
Air conditioner relay contacts stuck closed, coil open, shorted <A/C>		O								
Mode damper malfunction, not fully closed				O	O				O	
Air mix damper malfunction, not fully closed					O	O			O	
Ventilation/recirculation selection damper malfunction, not fully closed					O		O		O	
Condenser fan motor coil open, shorted <A/C>		O								Gr54
Condenser relay contacts stuck closed, coil open, shorted <A/C>		O								
Dual pressure switch coil open, shorted <A/C>		O								
Heater control malfunction	O	O	O	O	O	O	O			
Thermostat stays open			O							Gr14
Coolant level low			O							
Connector poor contact, harness open, faulty earth	O	O		O	O	O	O			Gr54
Fuse blown	O	O								
Air conditioner piping clogged, loose, incorrectly connected <A/C>		O								
Heater piping clogged, loose, incorrectly connected			O							
Duct incorrectly connected					O					
Heater and cooling unit clogged			O							
Condenser clogged <A/C>		O								
Condenser core restricted, accumulation of foreign matter <A/C>		O								
Receiver clogged, inefficient desiccant <A/C>		O								
Evaporator clogged <A/C>		O								
Control wire jammed, incorrectly installed				O	O		O		O	
Lever bent				O	O		O		O	
Lever sliding section worn, out of grease				O	O		O		O	

<A/C>: Air conditioner

---

M E M O

# ON-VEHICLE INSPECTION AND ADJUSTMENT

## 1. Recovery of Refrigerant

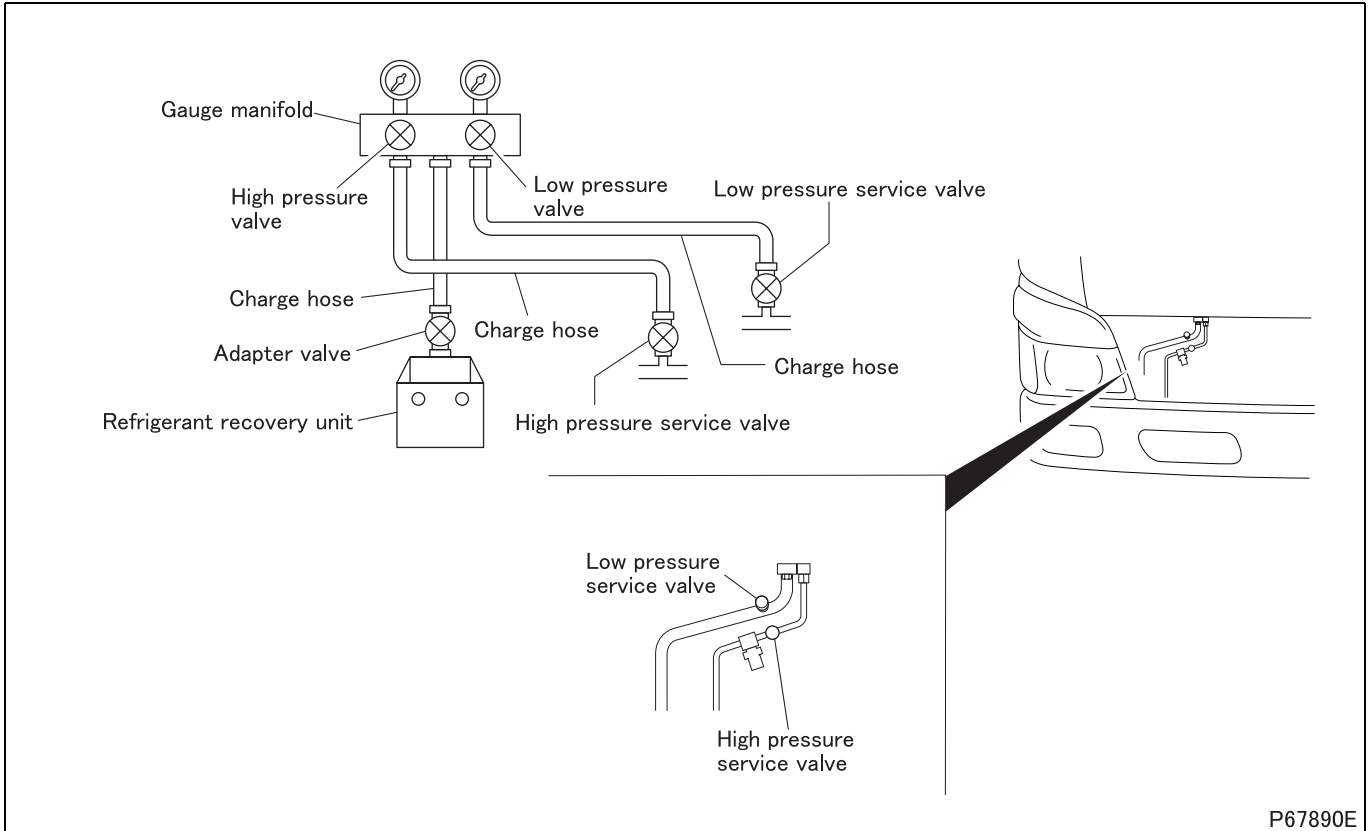

P67890E

- Recover refrigerant from the air conditioning system in accordance with the following flow chart.
- Installation of the refrigerant recovery unit

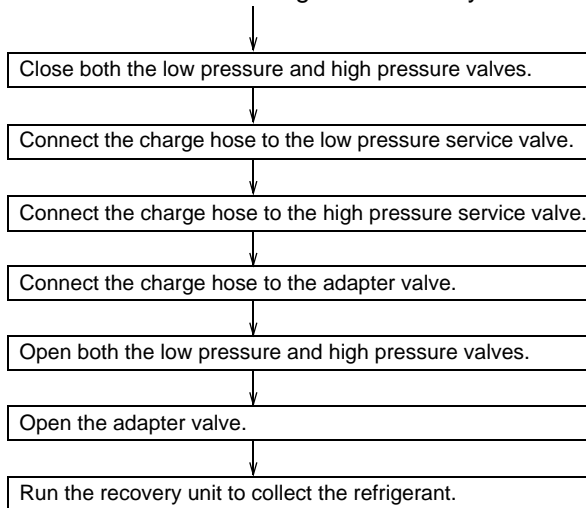

## 2. Recharging the System with Refrigerant

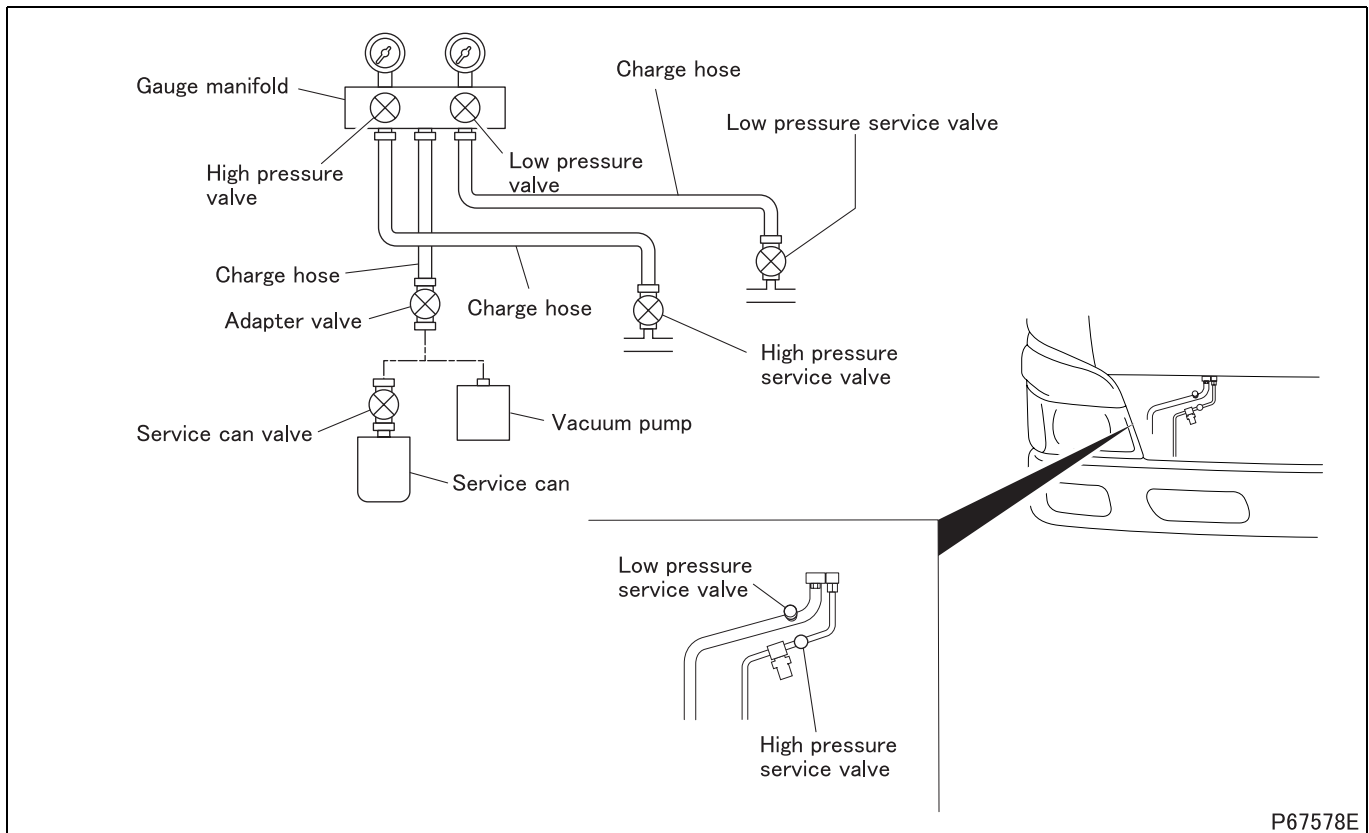
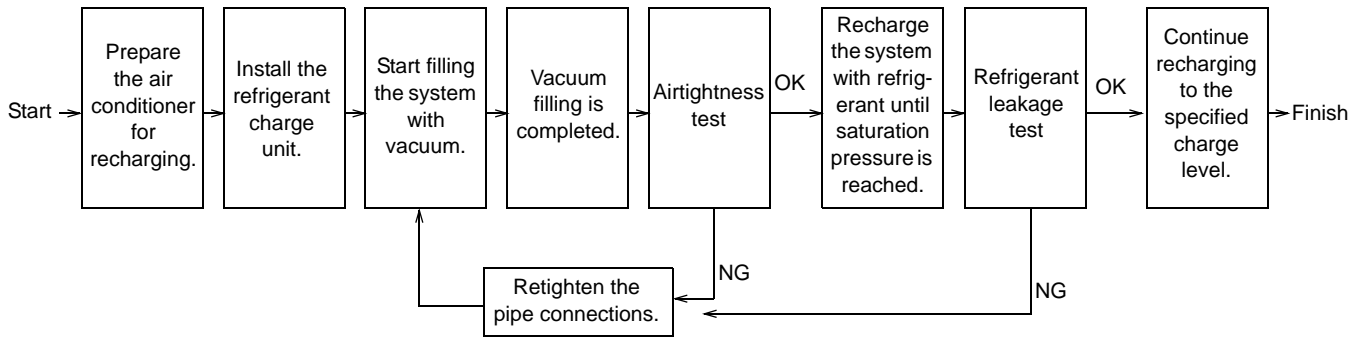

P67578E

- Recharge the system with refrigerant in accordance with the following flow chart.
- Installation of the refrigerant charge unit

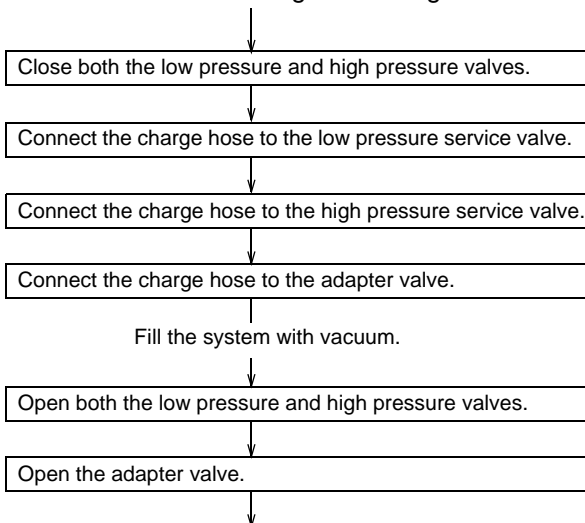

# ON-VEHICLE INSPECTION AND ADJUSTMENT

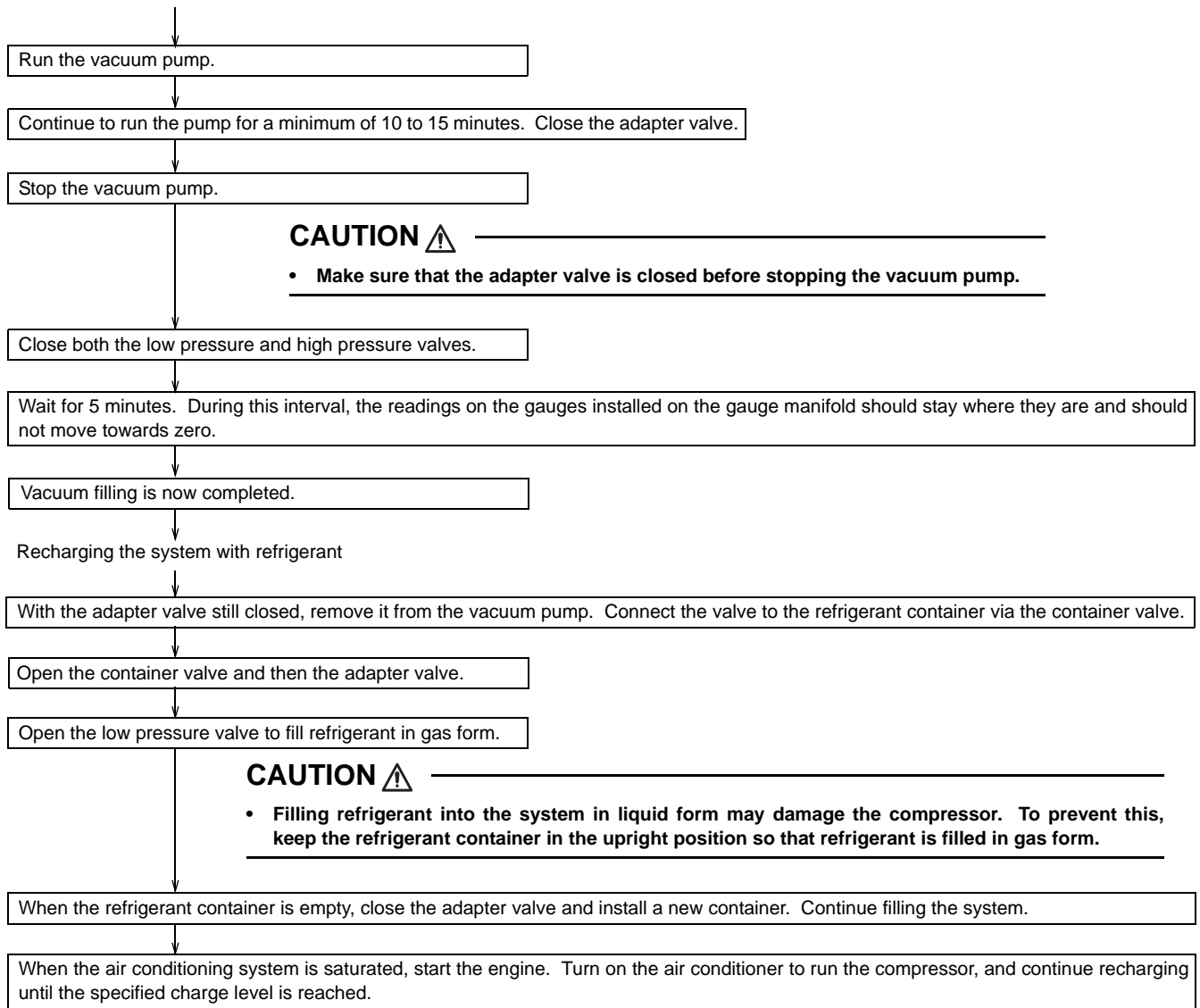

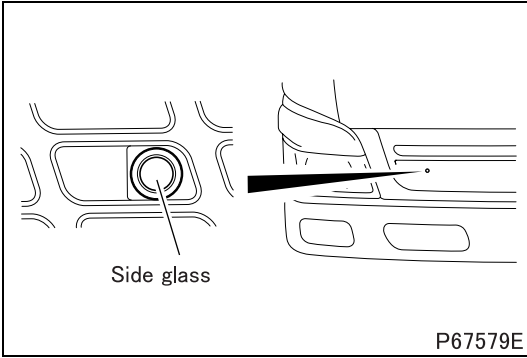

### 3. Checking Refrigerant Charge Level



- To check the refrigerant charge level, observe the flow of refrigerant through the sight glass. If the visual inspection indicates a low charge level, add refrigerant.
- The visual check should be performed under the following conditions.
  - Engine speed: 1400 rpm
  - Air conditioner switch: ON
  - Fan speed control dial: 4 (MAX)
  - Temperature control dial: MAX COOL
  - Fresh/recirculation changeover switch: Indicator lamp in the switch (OFF Fresh)
  - Doors: Fully open

**CAUTION** ⚠

- **When no or low level of refrigerant is checked, stop the air conditioner immediately. Running it with this condition for long time causes the compressor to seize.**

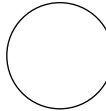
	Normal level	Low level	No refrigerant
Sight glass	 <p>P06554</p> <p>With a careful look, something like mist can be seen flowing.</p>	 <p>P06553</p> <p>Air bubbles are seen flowing at all times. The refrigerant may be transparent or whitish.</p>	 <p>P06552</p> <p>The refrigerant is almost transparent. Air bubbles may be seen flowing, but they disappear when the engine is revved up and down.</p>
High/low pressure piping	The high pressure piping is hot while the low pressure piping is cold.	The high pressure piping is warm while the low pressure piping is slightly cold.	There is almost no difference in temperature between the high and low pressure piping.

# ON-VEHICLE INSPECTION AND ADJUSTMENT

## 4. Adding Refrigerant

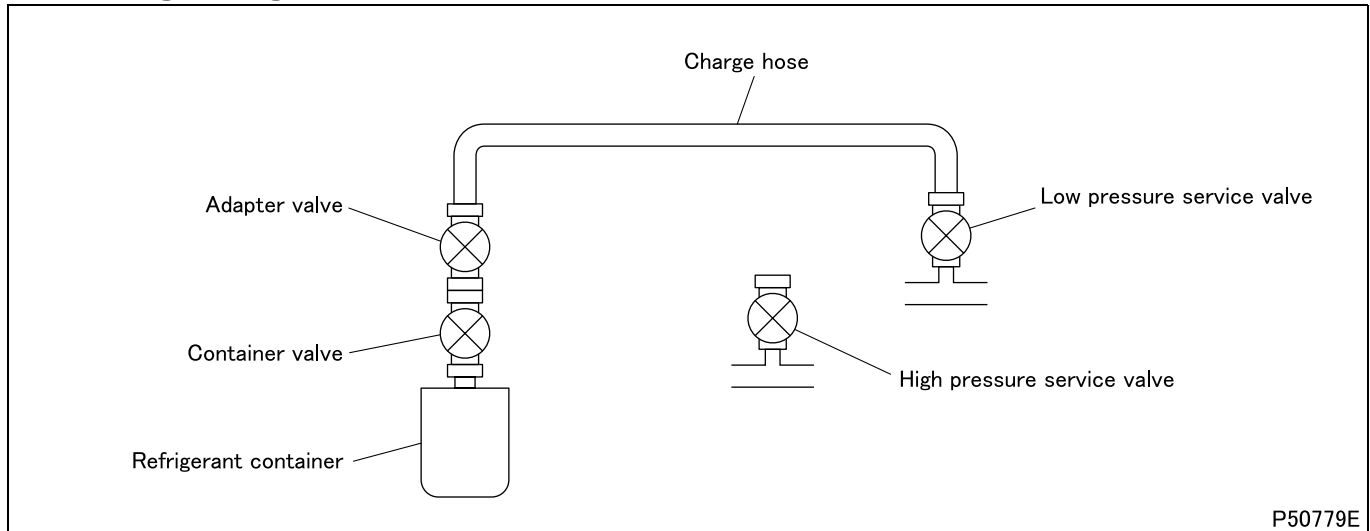

- Add refrigerant in accordance with the following flow chart.

With the adapter valve closed, connect the charge hose to the low pressure service valve.

### CAUTION ⚠

- If the charge hose is connected to the high pressure service valve, refrigerant may flow back, possibly damaging the refrigerant container and charge hose.

Open and close the adapter valve to bleed air of the charge hose. After air bleeding is completed, close the adapter valve.

Take the refrigerant container and valve assembly. With the container valve closed, connect the assembly to the adapter valve.

### CAUTION ⚠

- Filling refrigerant into the system in liquid form may damage the compressor. To prevent this, keep the refrigerant container in the upright position so that refrigerant is filled in gas form.

Open the container valve and then the adapter valve.

Start the engine.

Set the temperature control to MAX COOL. Turn on the air conditioner to run the compressor.

Continue adding refrigerant while observing the sight glass for charge level.

When "normal level" is confirmed through the sight glass, add refrigerant further 50 g {1.76 oz}.

When charging is completed, close the adapter and container valves. Remove the charge hose and the refrigerant container from the low pressure service valve.

If there is still some refrigerant in the container, keep it for the next opportunity. Be sure to keep the container valve closed.



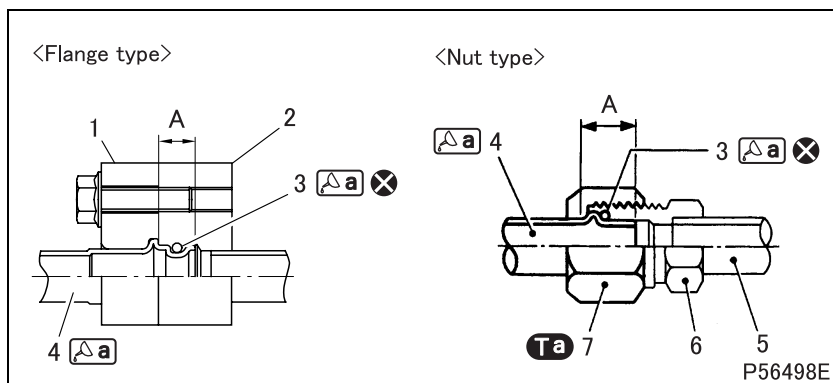

- 1 Flange (pipe end) <Flange type>
- 2 Flange (mating end) <Flange type>
- 3 O-ring
- 4 Pipe
- 5 Pipe <Nut type>
- 6 Union <Nut type>
- 7 Nut <Nut type>

A: Refrigerating machine oil application area

⊗: Non-reusable parts

## Tightening torque (Unit: N·m {kgf·m})

Mark	Parts to be tightened	Tightening torque	Remarks
⊿a	Nut	11.8 to 14.7 {1.2 to 1.5}	—

## Lubricant and/or sealant

Mark	Points of application	Specified lubricant and/or sealant	Quantity
⊿a	O-ring	Refrigerating machine oil SUN PAG56	As required
	Outer periphery of pipe end (area A)		

- There are 2 types of air conditioner pipe/hose connections: flange type and nut type. When connecting/tightening the connections, observe the following precautions.

## CAUTION

- The connected parts are sealed by the O-ring. Be careful not to damage the O-ring, such as by twisting.
- The O-rings are exclusively designed for HFC-134a refrigerant and are not reusable. The O-rings are available at the MITSUBISHI HEAVY INDUSTRIES, LTD. service stations.
- Never tighten the nut-type connection by rotating the union. This will deform the piping, allowing refrigerant to leak out. Tighten by rotating the nut while holding the union in position.

# COMPRESSOR

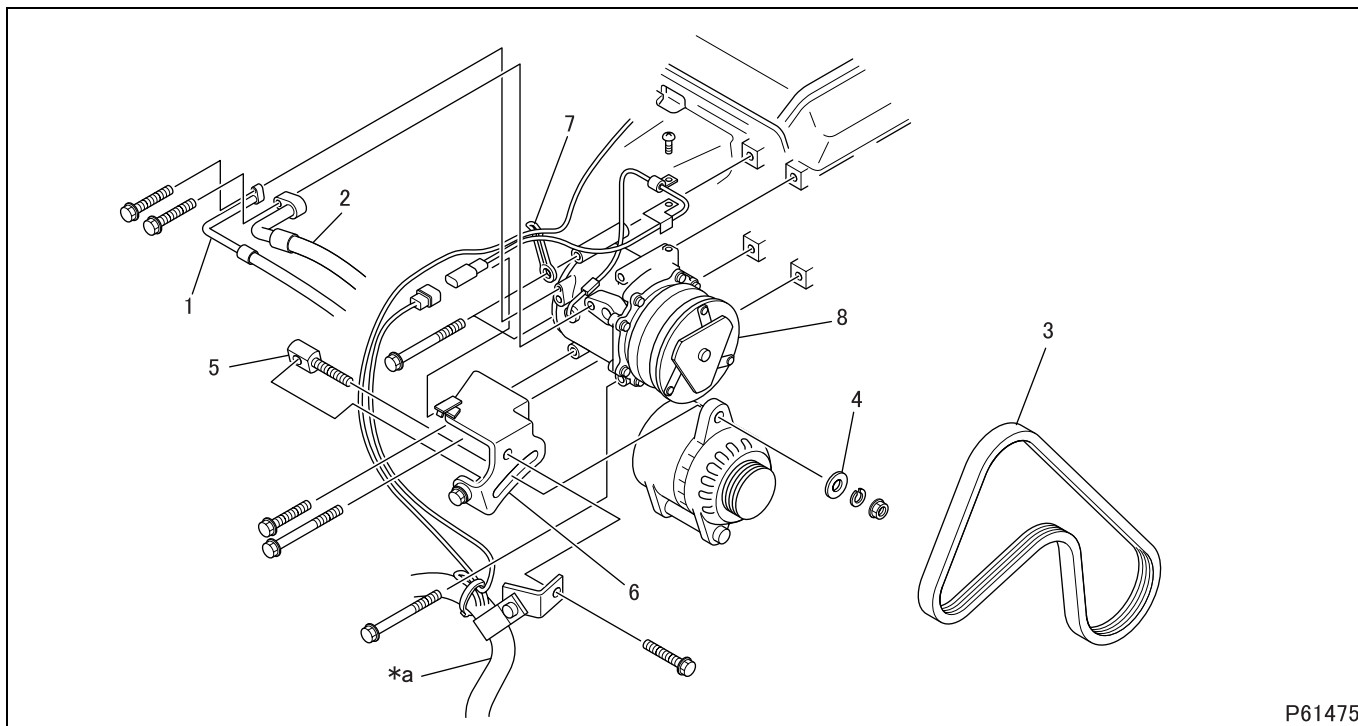

P61475

## ● Disassembly sequence

- |   |                   |
|---|-------------------|
| 1 Discharge hose (high pressure side)<br>(See AIR CONDITIONER PIPE CONNECTING.) | 5 Shaft           |
| 2 Suction hose (low pressure side)<br>(See AIR CONDITIONER PIPE CONNECTING.)    | 6 Adjusting plate |
| 3 V-ribbed belt   | 7 Clamp           |
| 4 Spacer  | 8 Compressor      |
- \*a: Vehicle harness

## CAUTION

- Recover the refrigerant before removing the discharge hose and suction hose.
- Plug discharge hose, suction hose, and compressor after removal to keep them free from dust etc.

## ● Installation sequence

Follow the removal sequence in reverse.

## CAUTION

- After installation, tension the V-belt to specification. (See Gr14.)

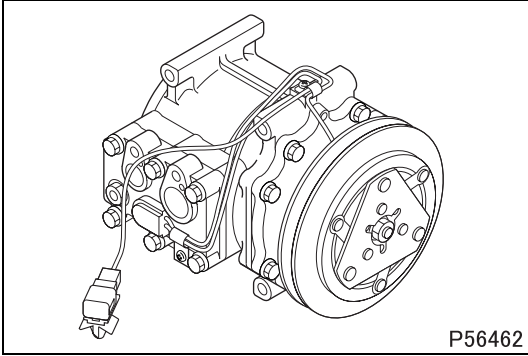
**◆ Inspection procedure ◆****■ Inspection: Compressor**

- Check the compressor proper for malfunction and oil leakage.
- If there is anything wrong with the compressor, have it overhauled at a nearest MITSUBISHI HEAVY INDUSTRIES, LTD. service station.

# CONDENSER, RECEIVER

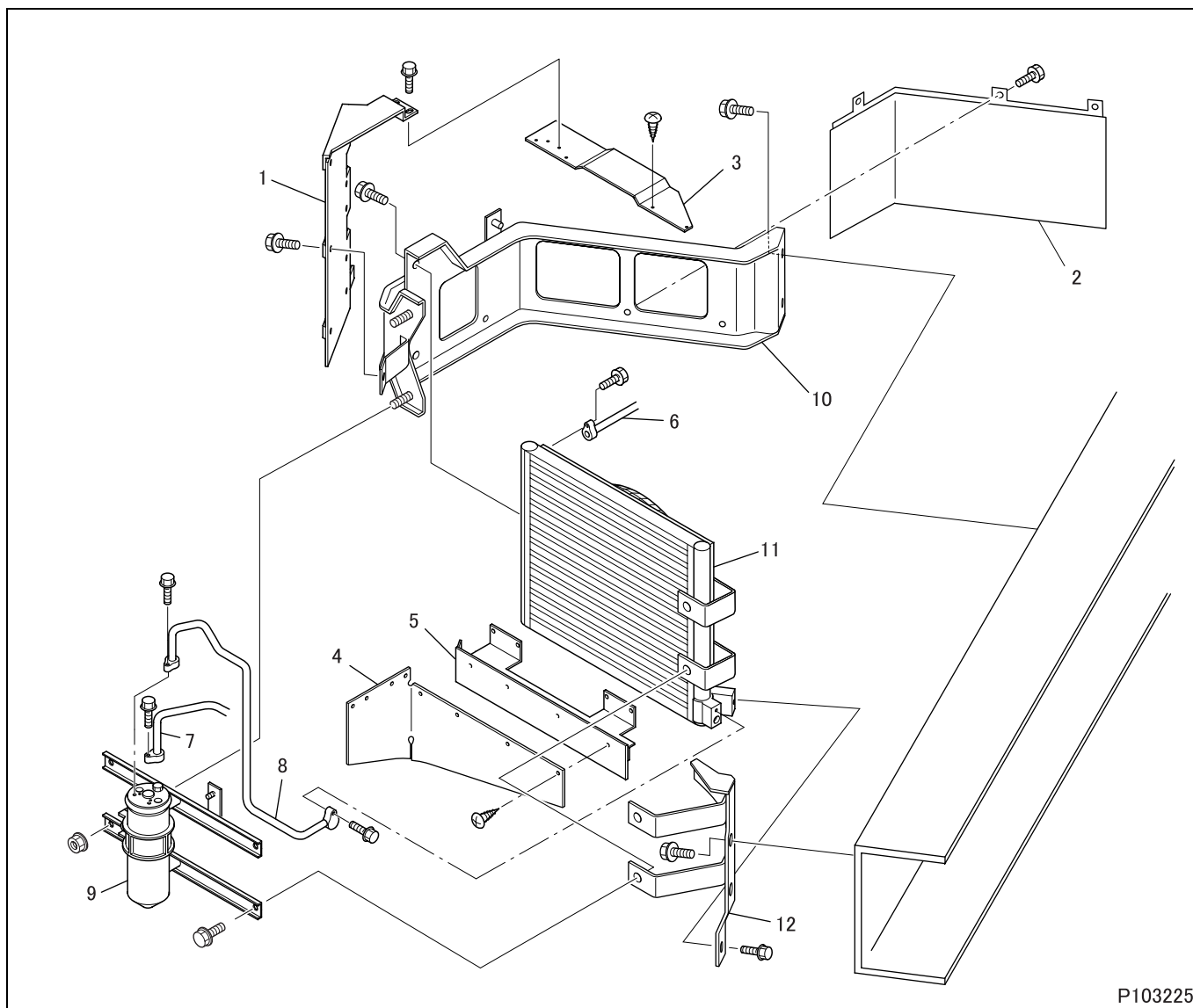

P103225

## ● Removal sequence

- |                                   |   |
|-----------------------------------|---|
| 1 Baffle plate                    | 7 Liquid hose (heater and cooling unit end) |
| 2 Intercept plate                 | 8 Liquid pipe                               |
| 3 Baffle plate (upper)            | 9 Receiver                                  |
| 4 Eva plate                       | 10 Condenser rear bracket                   |
| 5 Baffle plate (lower)            | 11 Condenser                                |
| 6 Discharge hose (compressor end) | 12 Condenser front bracket                  |

## ● Installation sequence

Follow the removal sequence in reverse.

- See the CONNECTING AIR CONDITIONER PIPING section for the installation of hose and pipe.

## ● Installation sequence

Follow the removal sequence in reverse.

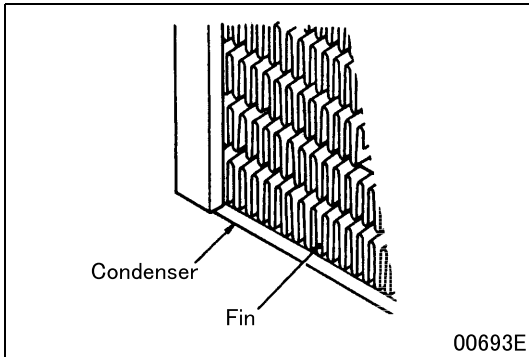
**◆ Inspection procedure ◆****■ Inspection: Condenser**

- If the condenser fins are clogged with dirt, dust or other foreign matter, wash it out. Any deformed fins should be straightened using a spatula or the like.

# HEATER CONTROL

<Left-hand Drive Vehicle>

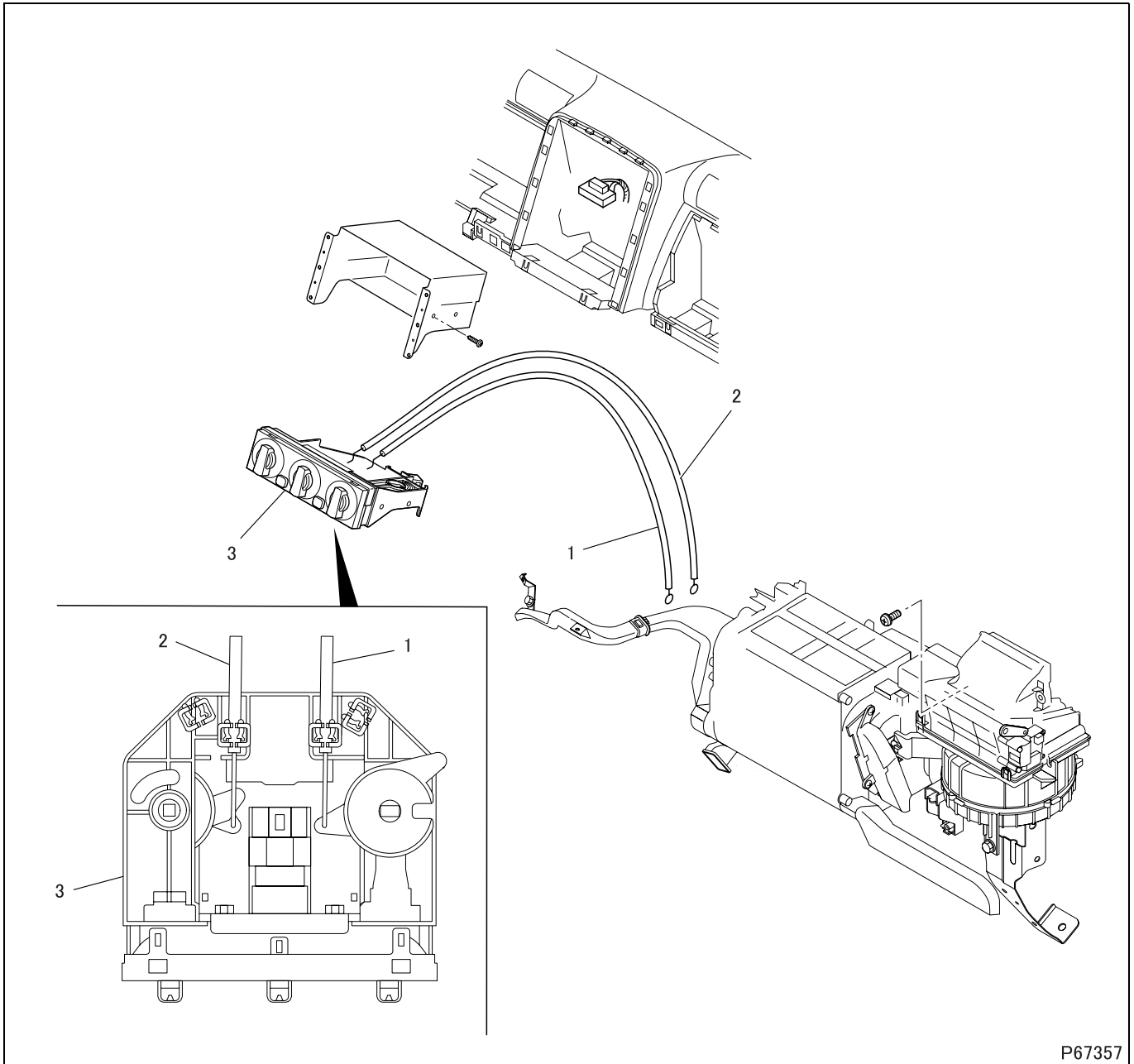

P67357

## ● Removal sequence

- 1 Air mix control cable (BLACK)
- 2 Mode selection control cable (NATURAL)
- 3 Heater control unit

## CAUTION

- Never remove the cable(s) from the heater control(s) except when the control cable(s) needs to be replaced. Failure to observe this may damage the claws of the cable clip.

## ● Installation sequence

Follow the removal sequence in reverse.

### ◆ Work before removal ◆

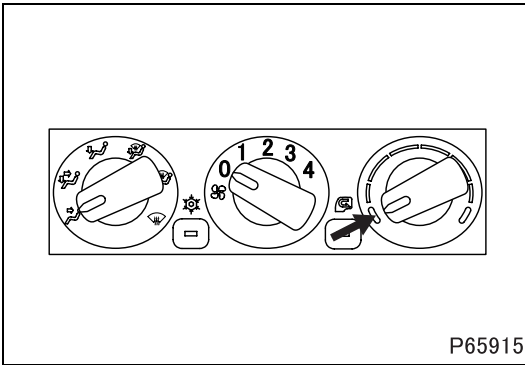

#### ■ Adjustment: Temperature control knob

- Before disconnecting the control cables, turn the temperature control knob of the heater controls to the MAX-COOL position.

### ◆ Removal procedure ◆

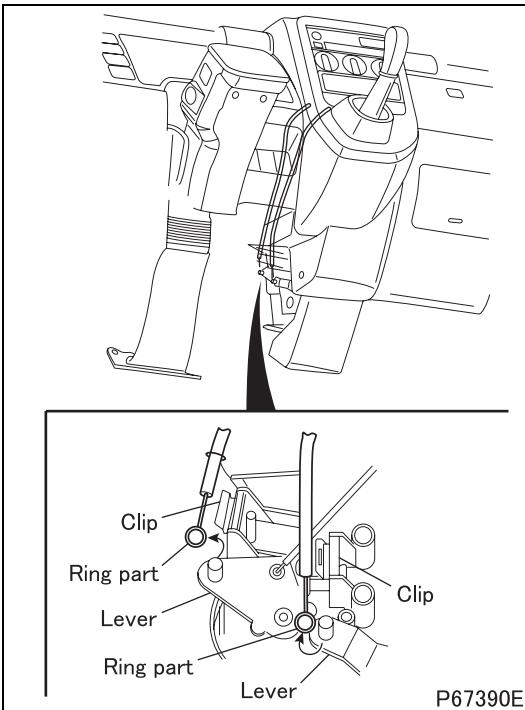

#### ■ Removal: Control cables

- Before disconnecting the cables from the levers, put pairing marks on each cable and its lever.
- Disconnect the control cables from the heater unit.

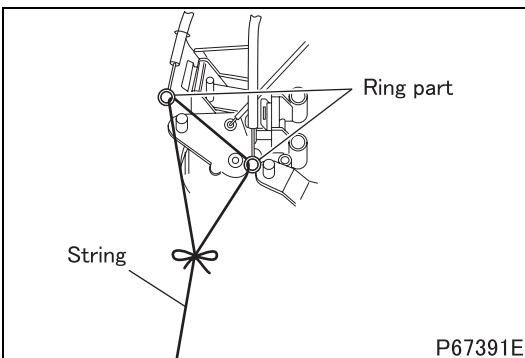

- In order that the control cables can be pulled back at the time of installation, attach string to the ring parts of the cables as shown in the illustration.

# HEATER CONTROL

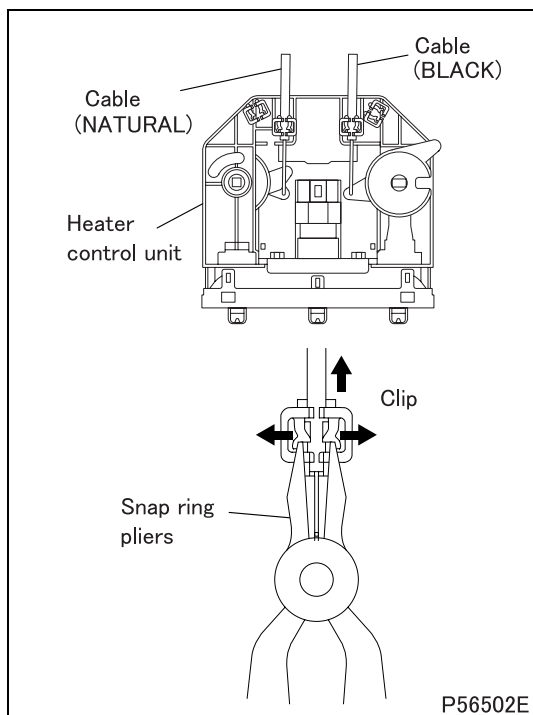

- Remove the heater control unit from the instrument panel.
- Use snap ring pliers to disconnect the cable(s) from the heater control(s).

## ◆ Work before installation ◆

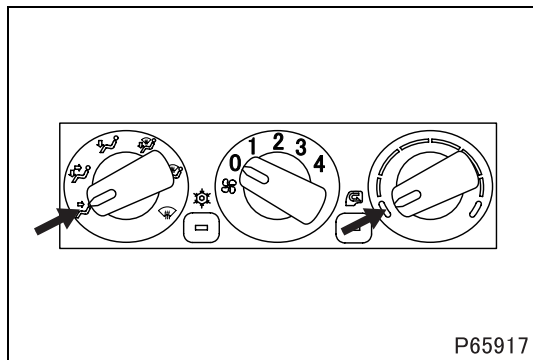

## ■ Adjustment: Heater control unit knobs

- At the heater controls, turn the temperature control knob to the MAX-COOL position and turn the mode selector knob to the face position before reconnecting the control cables.



## ◆ Installation procedure ◆

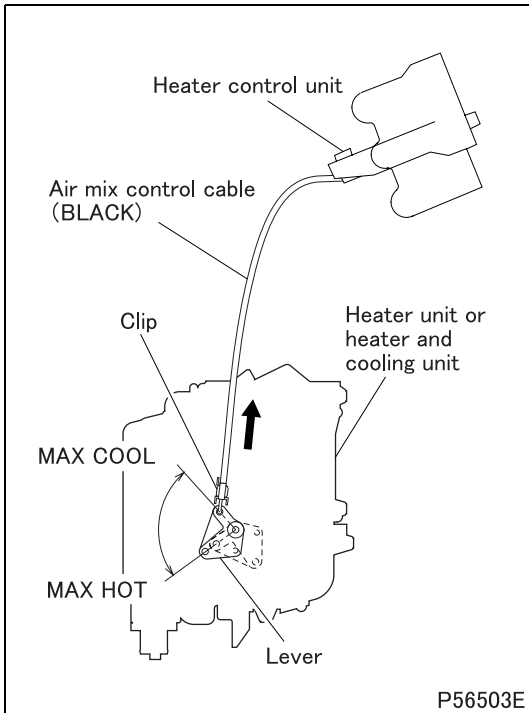

### ■ Installation: Air mix control cable

- Install one end of the air mix control cable to the heater control unit.
- Set the unit's temperature control dial to MAX COOL.
- Pull back the control cable using the string attached at the removal procedure.
- Install the other end of the air mix control cable to the lever on the heater unit or heater and cooling unit.
- With the air mix control cable connected to the lever, pull the cable in the direction of the arrow to move the lever to MAX COOL (upper) position. Clip the cable into the position.
- Move the temperature control knob to MAX COOL and MAX HOT. Make sure that the lever moves to the corresponding MAX COOL and MAX HOT positions. If not, repeat the above sequence to correctly install the cable. Also, make sure that the cable being installed is in the correct color.

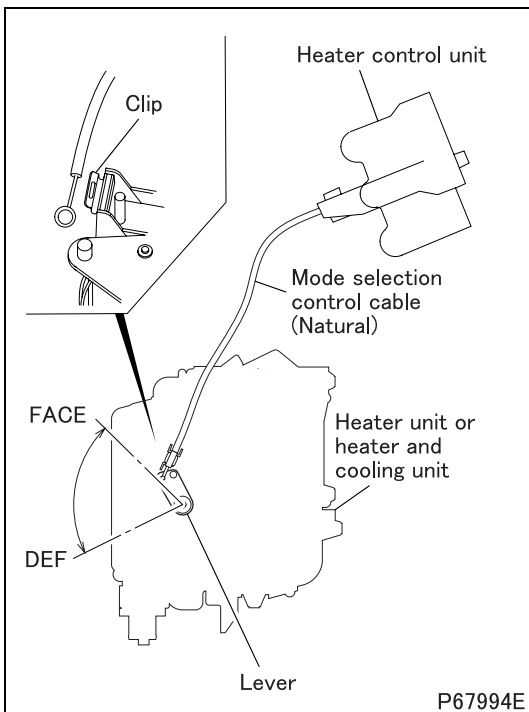

### ■ Installation: Mode selection control cable

- Install one end of the mode selection control cable to the heater control unit.
- Set the unit's mode control dial to FACE.
- Pull back the control cable using the string attached at the removal procedure.
- Install the other end of the mode selection control cable to the lever on the heater unit or heater and cooling unit.
- With the mode selection control cable connected to the lever, and push the cable into the clip.
- Move the mode control knob to FACE and DEF. Make sure that the lever moves to the corresponding FACE and DEF positions. If not, repeat the above sequence to correctly install the cable. Also, make sure that the cable being installed is in the correct color.

# AIR DUCT

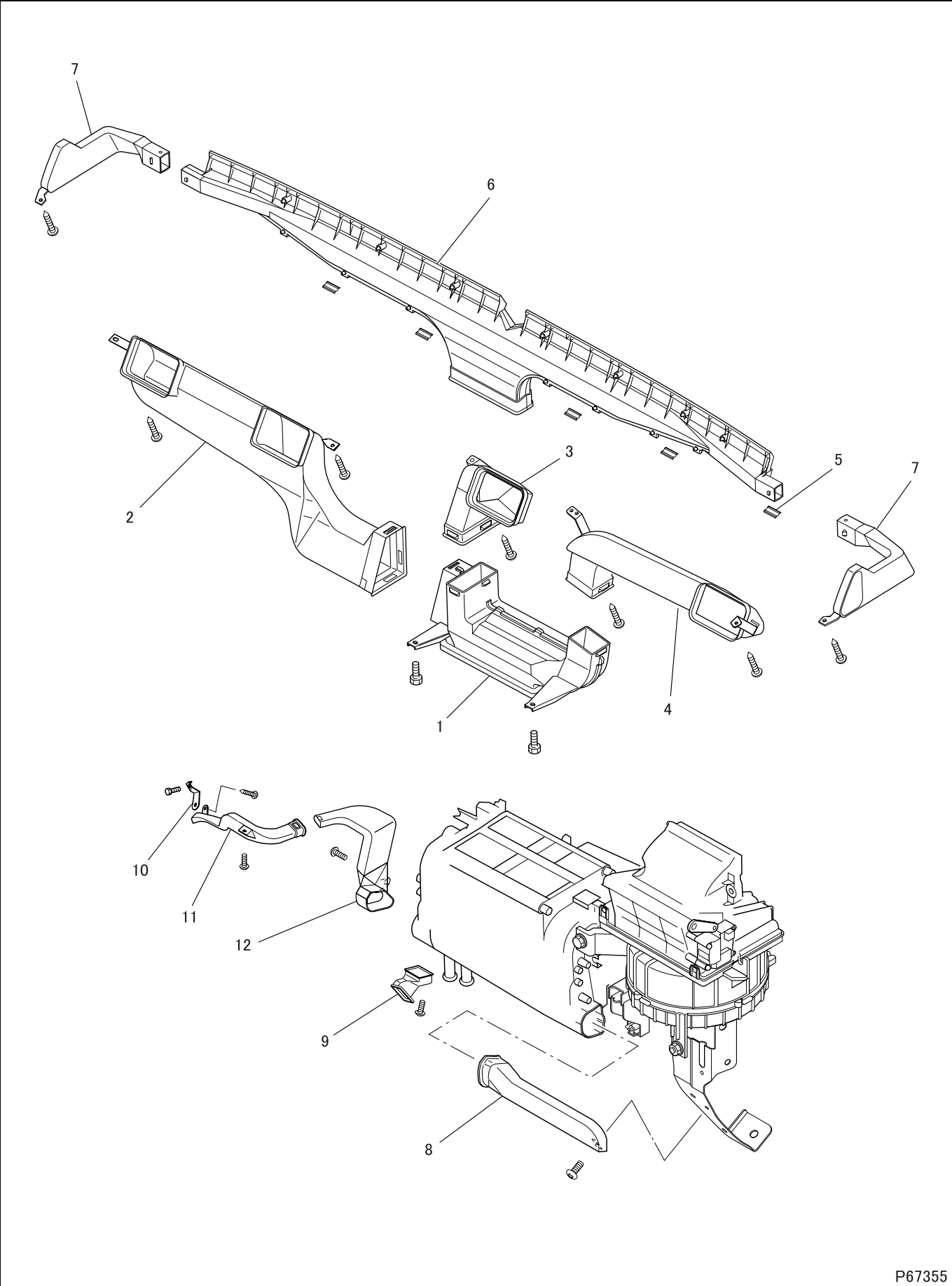

### ● Removal sequence

- |                        |                       |
|------------------------|-----------------------|
| 1 Center duct          | 7 Side defroster duct |
| 2 Driver face duct     | 8 Passenger foot duct |
| 3 Center face duct     | 9 Center foot duct    |
| 4 Passenger face duct  | 10 Foot duct bracket  |
| 5 Clip ( × 7)          | 11 Driver foot duct B |
| 6 Front defroster duct | 12 Driver foot duct A |

### ● Installation sequence

Follow the removal sequence in reverse.

### ◆ Installation procedure ◆

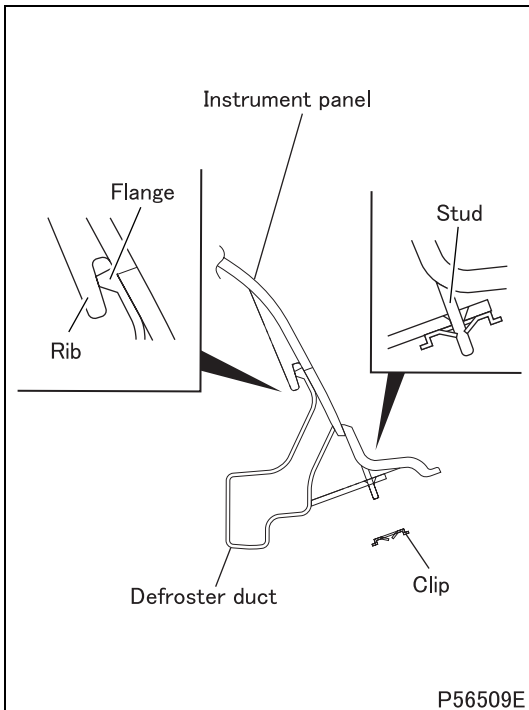

#### ■ Installation: Front defroster duct

- Insert the front defroster duct flanges into the instrument panel ribs.
- Insert the instrument panel studs into the front defroster duct holes and clip them together.

# HEATER AND COOLING UNIT, BLOWER

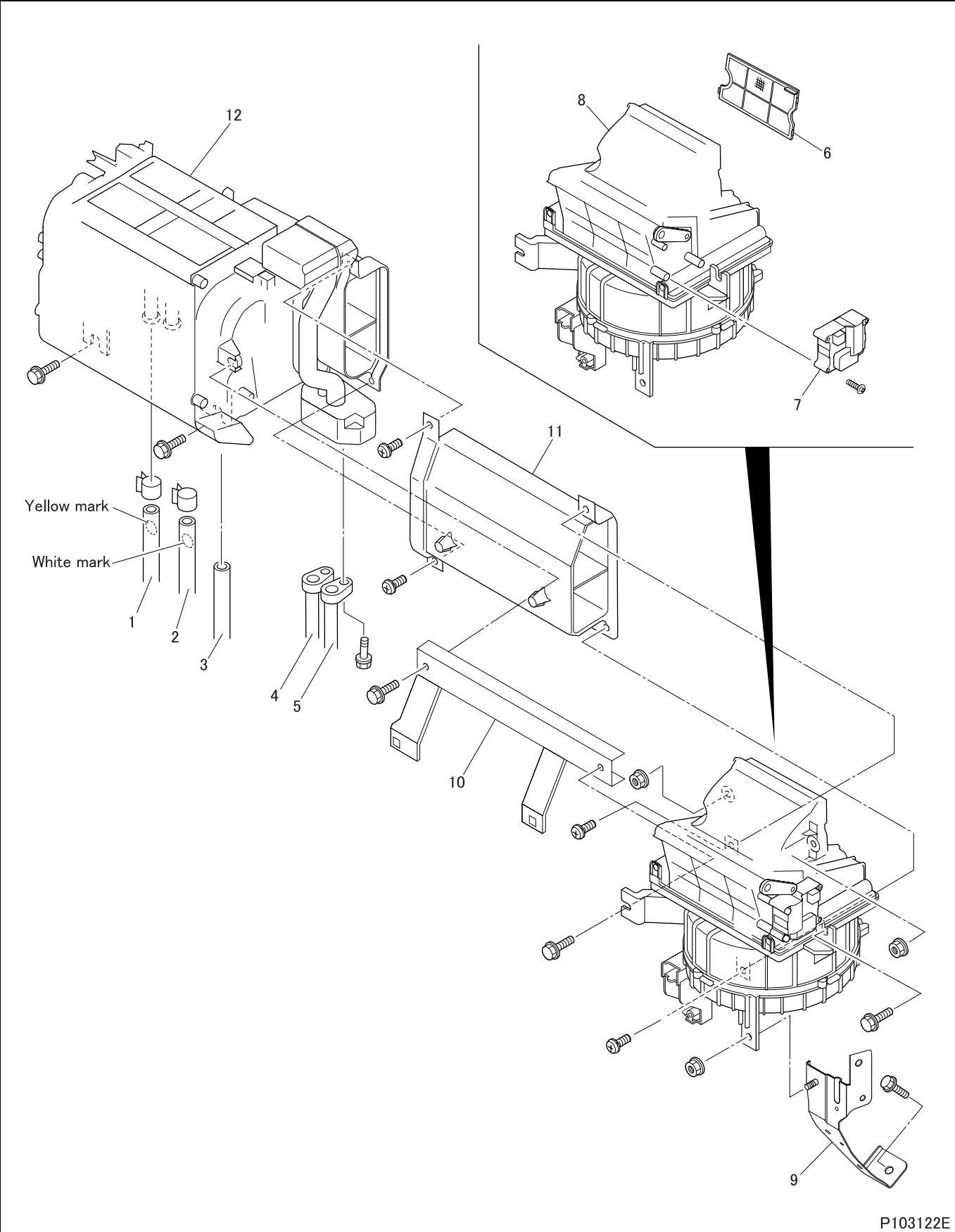

P103122E

### ● Removal sequence

- |                                  |  |
|----------------------------------|--|
| 1 Heater hose (outlet)           | 7 Fresh/recirculation changeover motor           |
| 2 Heater hose (return)           | 8 Blower   |
| 3 Drain hose                     | 9 Bracket  |
| 4 Discharge hose (high pressure) | 10 Bracket                                       |
| 5 Suction hose (low pressure)    | 11 Joint duct                                    |
| 6 Air filter                     | 12 Heater and cooling unit (See later sections.) |

- Remove the front grill before removing hoses. (See Gr51.)
- Drain coolant out of the radiator when removing the heater hoses. (See Gr14.)

### ● Installation sequence

Follow the removal sequence in reverse.

- See the CONNECTING AIR CONDITIONER PIPING section for the installation of hose and pipe.

### ◆ Installation procedure ◆

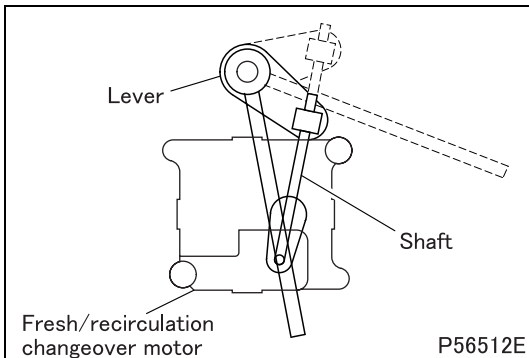

#### ■ Installation: Fresh/recirculation changeover motor

- With the lever set to the “Fresh” position, install the motor shaft through the lever.

# HEATER AND COOLING UNIT, BLOWER

## Heater Unit or Heater and Cooling Unit

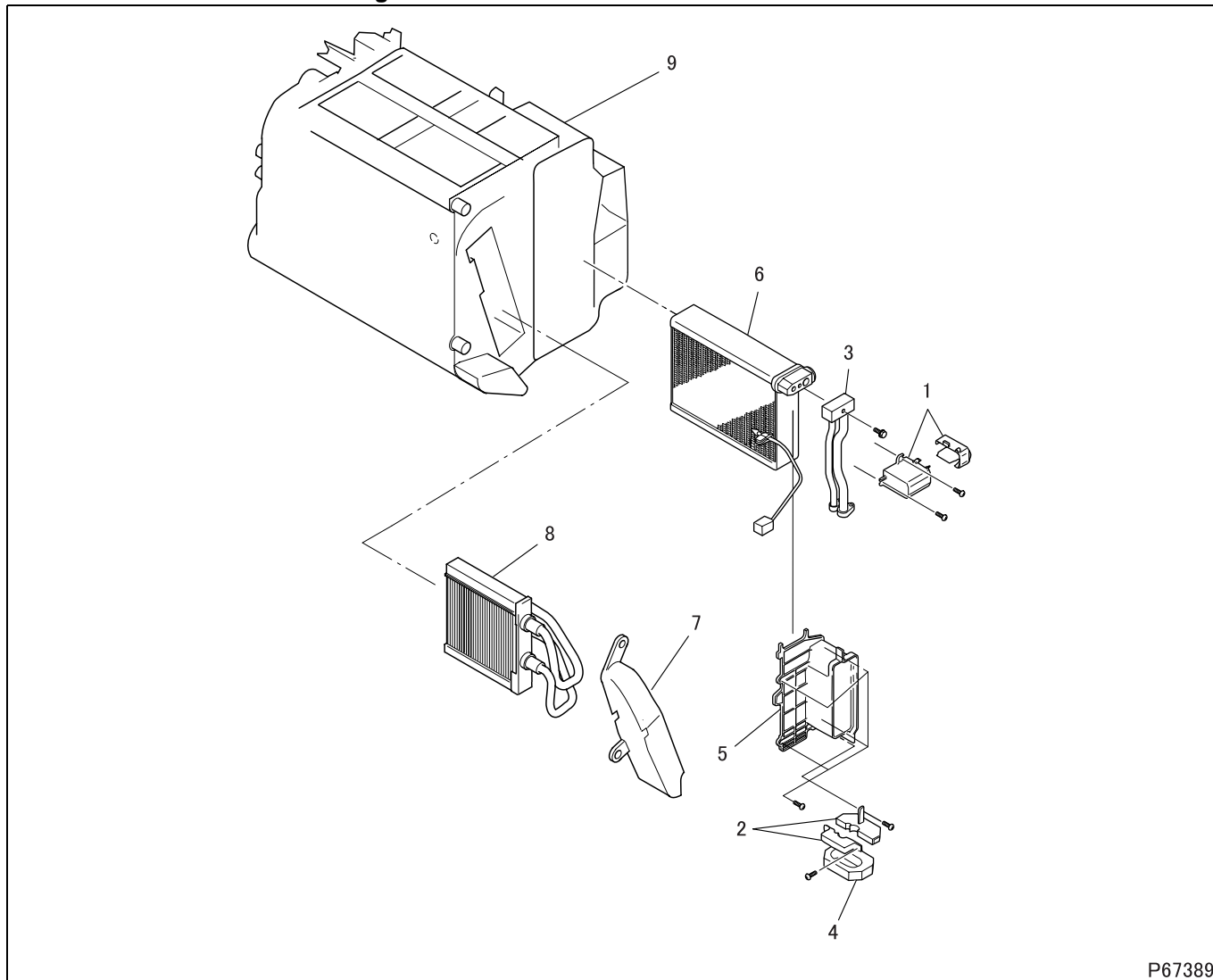

### ● Disassembly sequence

- 1 Cover <A/C>
- 2 Baffle cover <A/C>
- 3 Pipe assembly <A/C>
- 4 Rubber insulation <A/C>
- 5 Case cover
- 6 Evaporator assembly <A/C>
- 7 Cover
- 8 Heater core
- 9 Heater and cooling unit case

<A/C>: With air conditioner

### ● Assembly sequence

Follow the disassembly sequence in reverse.