GROUP 14 INDEX

SPECIFICATIONS	14-2
STRUCTURE AND OPERATION	
1. Cooling System (Flow of Coolant).....	14-4
2. Thermostat.....	14-5
3. Water Pump	14-5
TROUBLESHOOTING.....	14-6
ON-VEHICLE INSPECTION AND ADJUSTMENT	
1. Inspection and Adjustment of Belt Tension.....	14-8
2. Inspection of Cracks or Damage of the Belt	14-10
3. Coolant Replacement and Cleaning of Cooling System	14-11
4. Air Bleeding of Cooling System	14-13
5. Air/Gas Leakage Test	14-13
DISCONNECTION AND CONNECTION OF HOSES AND PIPES .	14-14
RADIATOR, FAN SHROUD	14-18
COOLING FAN, V-BELT AND WATER PUMP	14-26
TENSION PULLEY	14-29
THERMOSTAT	14-30
PRESSURE CAP AND WATER OUTLET CASE	14-32

SPECIFICATIONS

Item	Specifications
Cooling system	Forced water circulation system
Water pump	Belt-driven involute type
Thermostat	Wax pellet, bottom bypass type (with jiggle valve)
Automatic cooling fan coupling	Continuous control type
Radiator	Tube and corrugated fin type
Coolant capacity	L {qts}

M E M O

STRUCTURE AND OPERATION

1. Cooling System (Flow of Coolant)

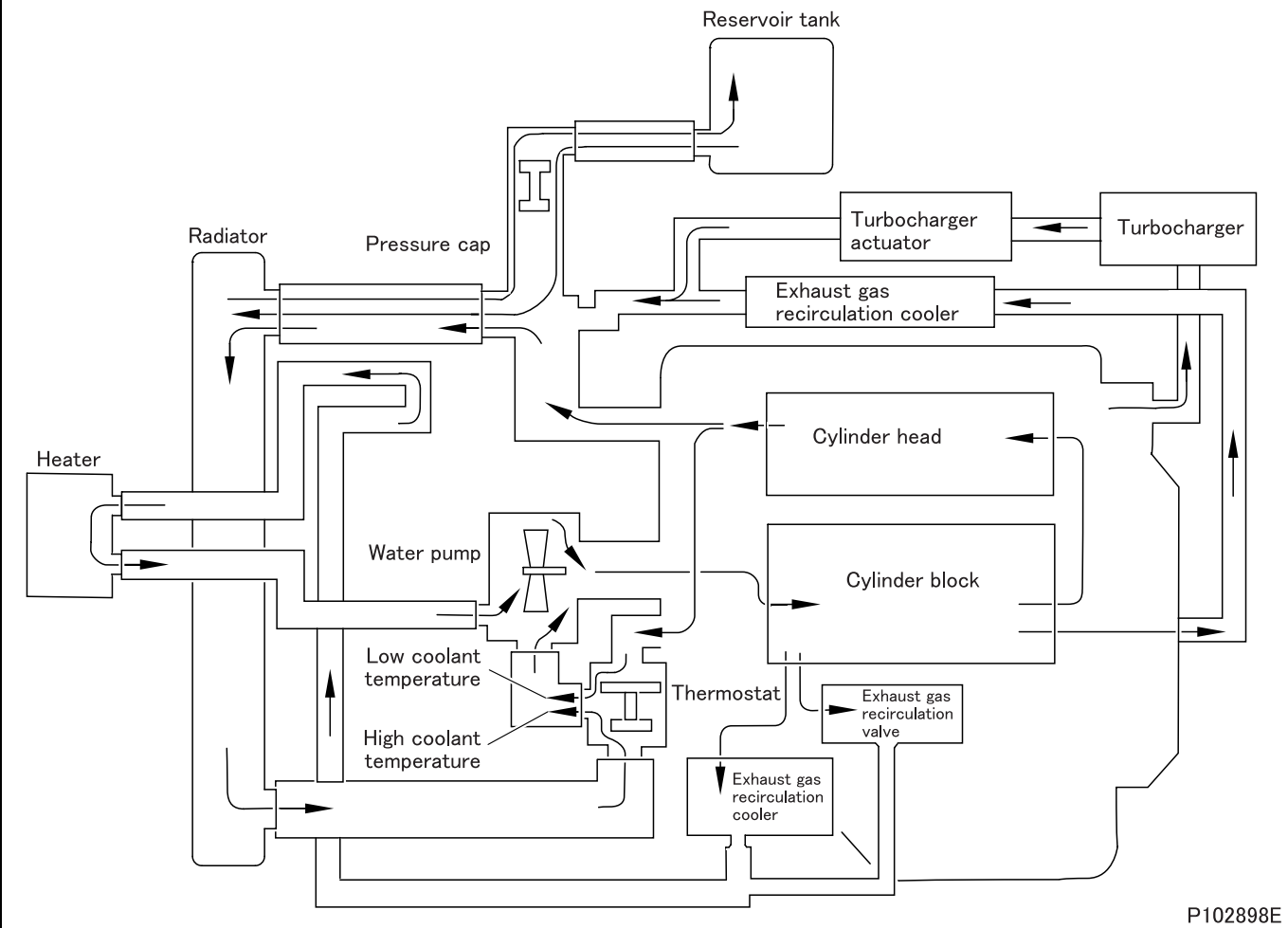

2. Thermostat

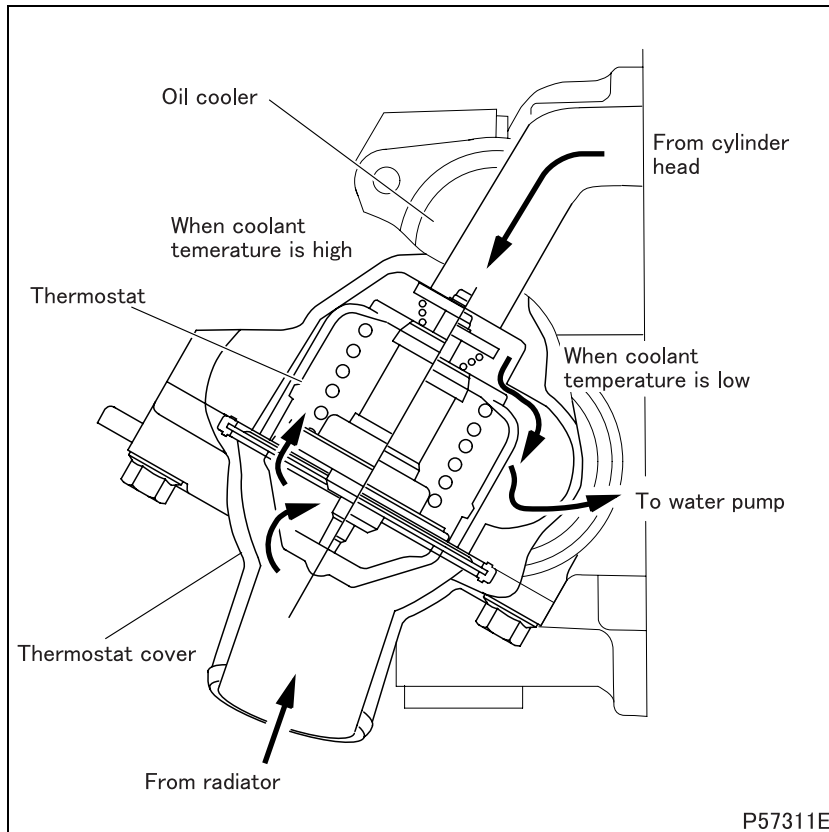

- It is a bottom bypass type that uses a wax-filled pellet as its flow-regulating element. When the wax is heated, it melts from solid to liquid, changing its total volume. This allows the valve to open or close in accordance with the coolant temperature, regulating and adjusting the flow of coolant to the radiator and to the cylinder head (bypassing the radiator).

3. Water Pump

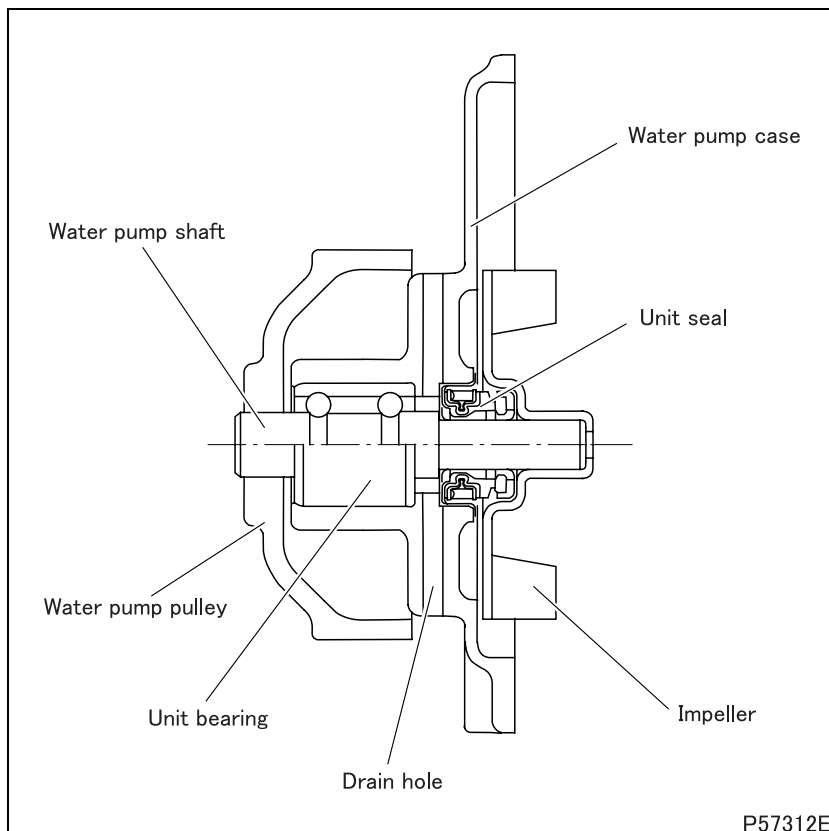

- The water pump has a drain hole to prevent coolant from entering the unit bearing in the case of defect of the unit seal.

TROUBLESHOOTING

Possible causes		Symptoms				Reference Gr
		Overheating (poor cooling)	Overcooling	Abnormal noise	Excessive coolant loss	
V-belt	Loose or damaged	O		O		
	Excessive tension			O		
	Oil on belt	O				
Water pump	Incorrectly mounted water pump	O			O	
	Defective gasket	O			O	
	Defective unit bearing	O		O		
	Defective impeller	O				
	Defective unit seal	O			O	
	Too loose fit of unit bearing on flange and impeller	O		O		
Thermostat	Incorrectly mounted case	O			O	
	Valve opening temperature too high (valve remains closed)	O				
	Valve opening temperature too low (valve remains open)		O			
Radiator	Clogged core	O				
	Cracked core and/or separation in welds	O			O	
	Cracks in upper tank and/or lower tank	O			O	
	Poor clinching of upper tank and/or lower tank	O			O	
	Defective packing of upper tank and/or lower tank	O			O	
Automatic cooling fan coupling	Defective bearing	O		O		
	Damaged bimetal	O				
	Contaminated bimetal	O	O			
	Silicon oil leakage	O		O		
Cylinder head	Incorrectly mounted cylinder head	O			O	Gr11
	Defective gasket	O			O	
Oil cooler	Incorrectly mounted oil cooler	O			O	Gr12
	Defective gasket	O			O	
	Leakage from coolant temperature sensor	O			O	
Exhaust gas recirculation system	Poor installation of exhaust gas recirculation cooler bracket	O			O	Gr17
	Poor installation of exhaust gas recirculation cooler	O			O	
	Poor installation of connectors	O			O	
	Poor installation of adapter	O			O	
	Damaged O-rings	O			O	

Symptoms		Overheating (poor cooling)	Overcooling	Abnormal noise	Excessive coolant loss	Reference Gr
Possible causes						
Breather cover	Poor installation of breather cover	○			○	Gr17
	Poor installation of gaskets	○			○	
	Damaged O-rings	○			○	
Poorly airtight pressure cap		○				
Insufficient coolant amount		○				
Clogged or scaled coolant passage		○				
Incorrectly connected hoses		○			○	
Poor installation of pipes		○			○	
Excessively low exterior temperature			○			

ON-VEHICLE INSPECTION AND ADJUSTMENT

1. Inspection and Adjustment of Belt Tension

CAUTION

- Make sure that there is no oil or grease on the belts. Belts soiled with oil or grease may easily slip, resulting in deteriorated performance of the cooling system.



Service standards (Unit: mm {in.})

Location	Maintenance item		Standard value	Limit	Remedy	
-	Belt tension	with air conditioner	When new	7 to 9 {0.28 to 0.35}	-	Adjust
			When reused	10 to 11 {0.39 to 0.43}		
		without air conditioner	When new	9 to 11 {0.35 to 0.43}		
			When reused	11 to 13 {0.43 to 0.51}		

Tightening torque (Unit: N·m {ft.lbs, kgf·m})

Mark	Parts to be tightened	Tightening torque	Remarks
-	Nut (for alternator adjustment)	50 {37, 5.1}	-
-	Bolt (for alternator retention)	90 {66, 9.2}	-

Special tools

Mark	Tool name and shape	Part No.	Application
	Belt tension gauge  P03612	MH062345	Measurement of tension of belt

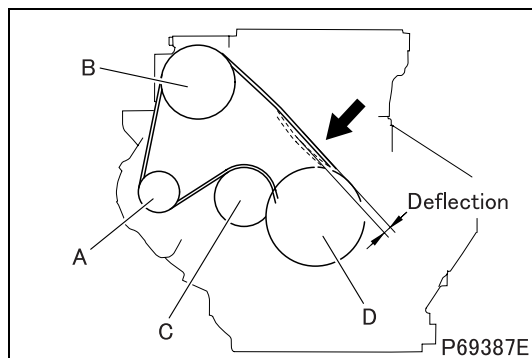



[Inspection]

- Press each belt at a central portion between pulleys with a force of approximately 98 N {72 lbs, 10 kgf} as shown in the illustration and measure the amount of deflection of the belt.

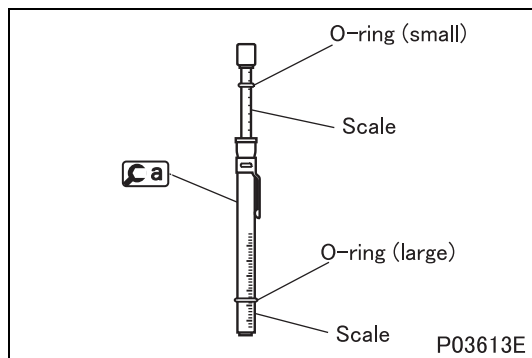
- A:** Alternator pulley
- B:** Air conditioner compressor pulley
- C:** Water pump pulley
- D:** Fan pulley



- Place the small O-ring on  at the scale mark corresponding to 98 N {72 lbs, 10 kgf} (press force).
- Place the large O-ring on  at the scale mark corresponding to the maximum permissible deflection value specified for the belt.

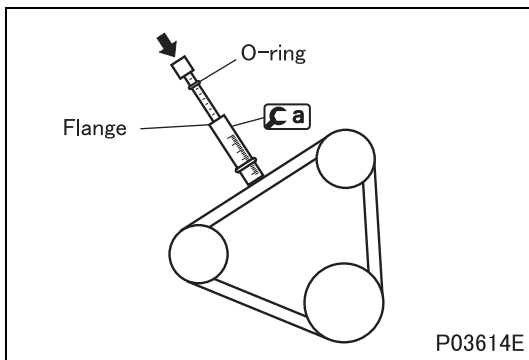

- Place **Ca** at a central portion between pulleys of the belt and push the handle (indicated by the arrow in the illustration) until the O-ring touches the flange.

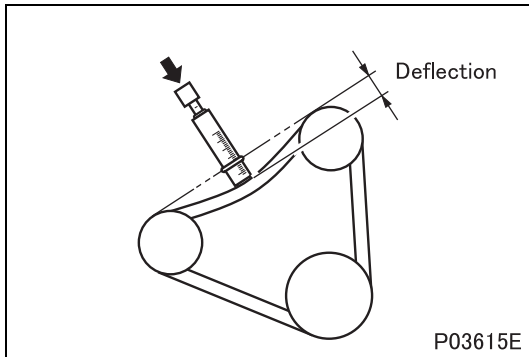

- Measure the amount of deflection of the belt.
- If the measured value deviates from the standard value range, adjust the tension of the belt as follows.

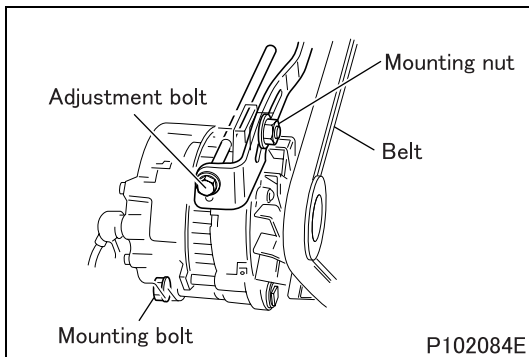

[Adjustment]

(1) Vehicles with air conditioner

- Loosen the alternator mounting nuts (2 locations) and adjust the tension of the belt by tightening or loosening the adjustment bolt.
- After the adjustment is completed, retighten the mounting nuts firmly.

CAUTION

- Excessive tension in the belt may damage not only the belt itself but also the bearings of the related components.

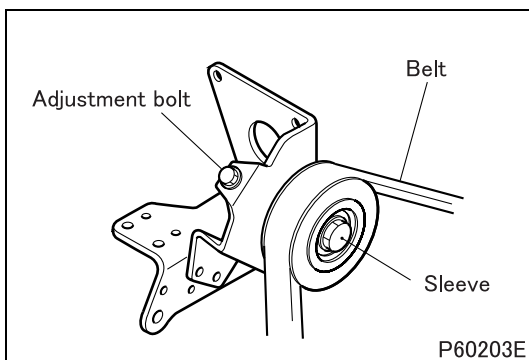

(2) Vehicles without air conditioner

- Loosen the tension pulley mounting sleeve and turn in or out the adjustment bolt to adjust the tension of the belt.
- After the adjustment is completed, retighten the mounting sleeve firmly.

CAUTION

- Excessive tension in the belt may damage not only the belt itself but also the bearings of the related components.

ON-VEHICLE INSPECTION AND ADJUSTMENT

2. Inspection of Cracks or Damage of the Belt

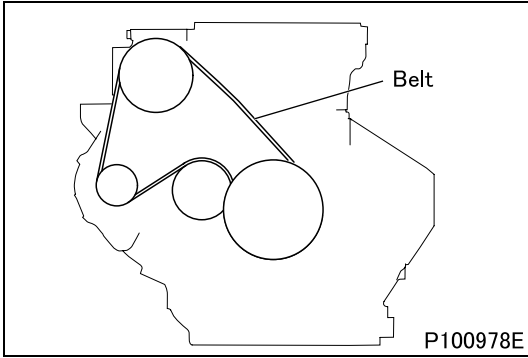

- Visually check the belts for possible cracks and damage.
- If any faults are found, replace the belts.

Belt condition	Remaining service life (reference)
<p>Wrinkled P69698E</p>	<ul style="list-style-type: none"> • The driving distance over which the belt can still be used is at least as long as that over which the belt has been used since the vehicle was new or since the belt was replaced (whichever is more recent).
<p>Cracks on belt surface P69699E</p>	<ul style="list-style-type: none"> • The driving distance over which the belt can still be used is about half of that over which the belt has been used since the vehicle was new or since the belt was replaced (whichever is more recent).
<p>Cracks extending to base rubber P69700E</p>	<ul style="list-style-type: none"> • The driving distance over which the belt can still be used is about a quarter of that over which the belt has been used since the vehicle was new or since the belt was replaced (whichever is more recent).
<p>Cracks extending to cords P69701E</p>	<ul style="list-style-type: none"> • The belt has reached the end of its service life and must be replaced.
<p>Partially missing rubber P69702E</p>	

3. Coolant Replacement and Cleaning of Cooling System

Tightening torque (Unit: N·m {lbf·ft, kgf·m})

Mark	Parts to be tightened	Tightening torque	Remarks
–	Radiator drain cock	15 ± 0.3 { 1.1 ± 0.2 , 0.15 ± 0.03 }	–
–	Water drain plug	24.5 ± 4.9 { 18 ± 3.6 , 2.5 ± 0.5 }	–

- Using the radiator for extended periods of time without cleaning can increase chance of rust and scale formation, which may cause engine overheating. The cooling system must be cleaned periodically.

NOTE

- Coolants containing longlife coolant require replacement every two years. This replacement interval can be extended to a maximum of six years by adding longlife coolant additive to the coolant once every year for the four years following the first two-year limit. For instructions on the use of this product, refer to the Owner's Handbook.**

3.1 Draining of coolant

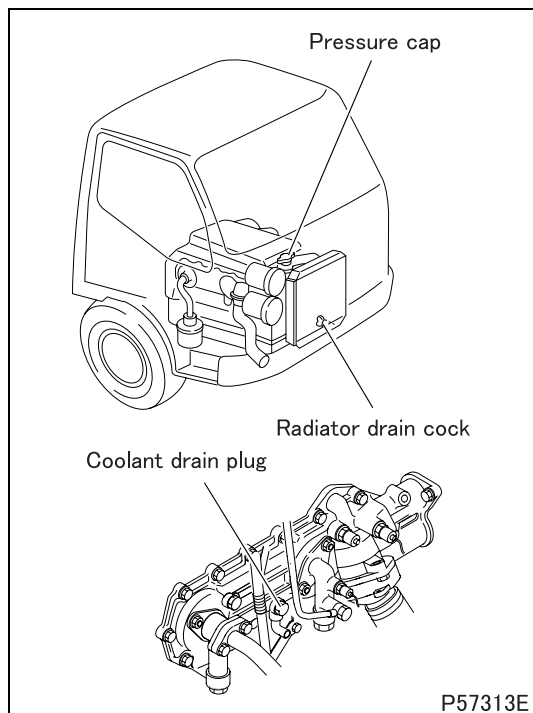

- Before draining the coolant, loosen the pressure cap to reduce the pressure in the cooling system. Remember to drain the coolant out of the reservoir tank as well.

WARNING

- Drain the coolant only after it has cooled sufficiently to avoid getting scalded.**
- Opening the pressure cap while the coolant temperature is still high can cause hot coolant to spray out. Cover the pressure cap with a cloth, and loosen it slowly to let the pressure out before opening it fully.**

3.2 Cleaning procedure

- Keep the coolant temperature at approximately 90°C { 195°F } so that the thermostat valve remains open and the coolant continues to circulate in the radiator.
- For the sake of convenience you can raise the coolant temperature quickly by covering the front of the radiator with corrugated cardboard or something similar.
- Set the temperature adjusting lever of the heater controller at maximum so that the coolant can circulate freely in the heater piping area.
- In cases where a great amount of rust has accumulated it often happens that as a result of cleaning the radiator starts leaking. Conduct a thorough check for leakage after cleaning.
- Soft water to be used should have the following properties.

CAUTION

- Do not use hard water as it causes scale and rust.**

Required properties of soft water

Total hardness	300 ppm or less
Sulfate SO_4^-	100 ppm or less
Chloride Cl^-	100 ppm or less
Total dissolved solids	500 ppm or less
pH	6 to 8

ON-VEHICLE INSPECTION AND ADJUSTMENT

- Select an appropriate cleaning method according to the condition of the cooling system as shown below.

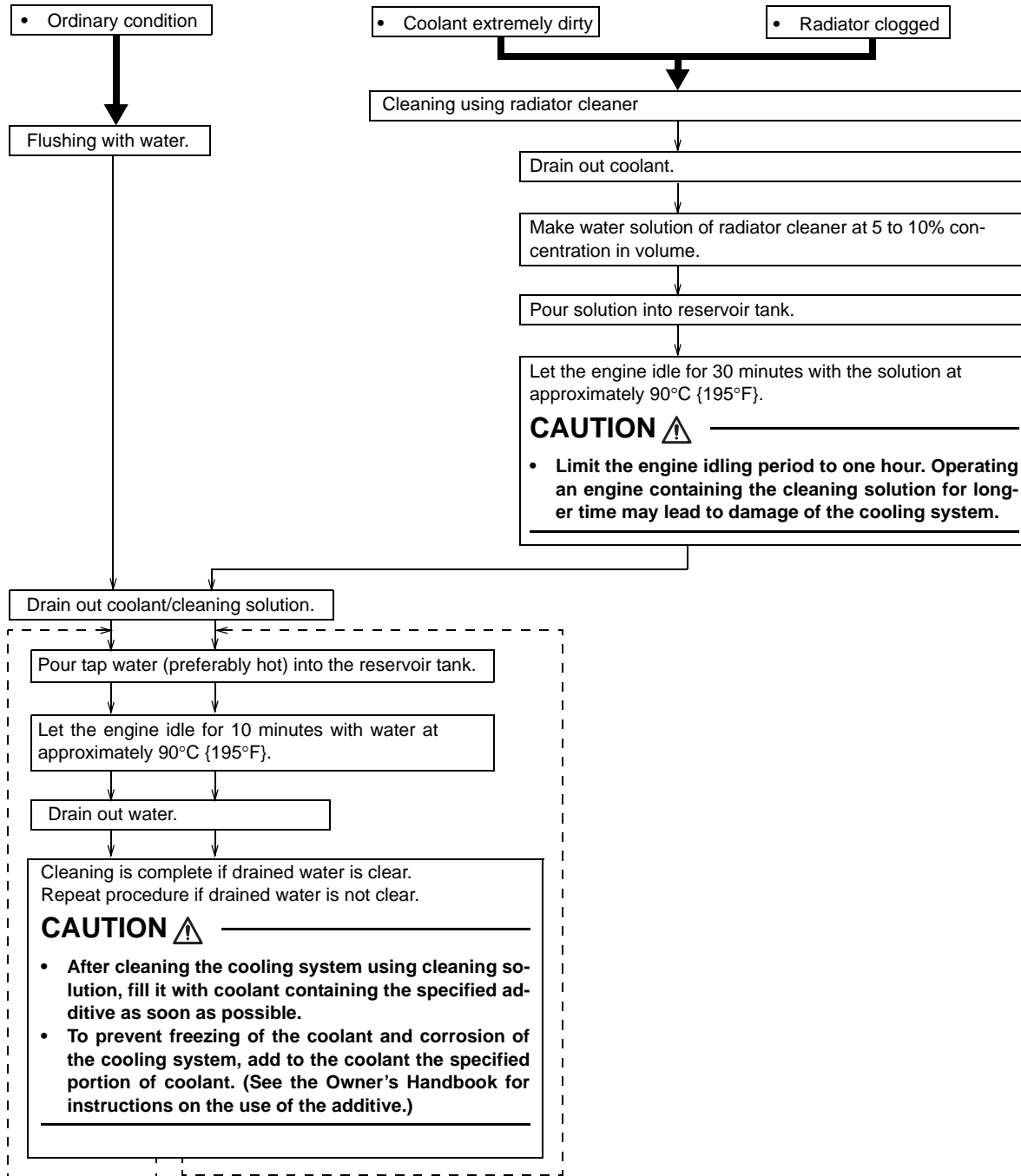

DANGER ⚠

- If you accidentally splash coolant or antirust treatment products in your eyes, wash it out immediately with water and seek medical attention.

WARNING ⚠

- Coolant is flammable. Keep them away from heat and flames.

4. Air Bleeding of Cooling System

- With the pressure cap removed and the coolant temperature at 90°C {195°F}, let the engine idle in order to bleed air completely out of the cooling system.
- After air bleeding is completed, refill the reservoir tank with coolant as needed.

5. Air/Gas Leakage Test

- Presence of air or exhaust gas in coolant accelerates corrosion of the cooling system components. To prevent this, carry out air/gas leakage tests in accordance with the following procedure.
- Remove the pressure cap.

WARNING ⚠

- **If the engine is hot, boiling coolant may spurt out from the filler port when the pressure cap is loosened. To avoid a scold, make sure to remove the pressure cap only when the coolant is cold.**

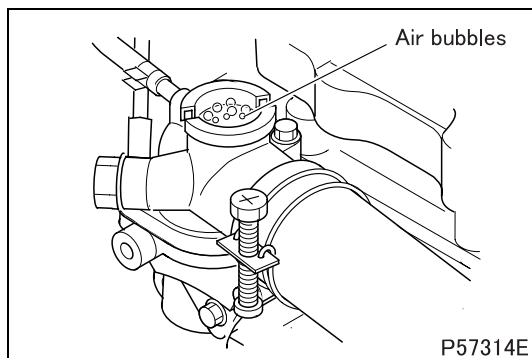

- Run the engine until the coolant temperature rises to approximately 90°C {195°F}.
- If air bubbles appear continuously through the filler port, there is air or exhaust gas penetrating into the cooling system.
- Presence of air in coolant can be an indication of loose cylinder head bolts, loose water pump mounting bolts, loose hose connections, and/or a damaged hose.
- Presence of exhaust gas in coolant can be an indication of a damaged cylinder head gasket and/or cracks in the cylinder head.

DISCONNECTION AND CONNECTION OF HOSES AND PIPES

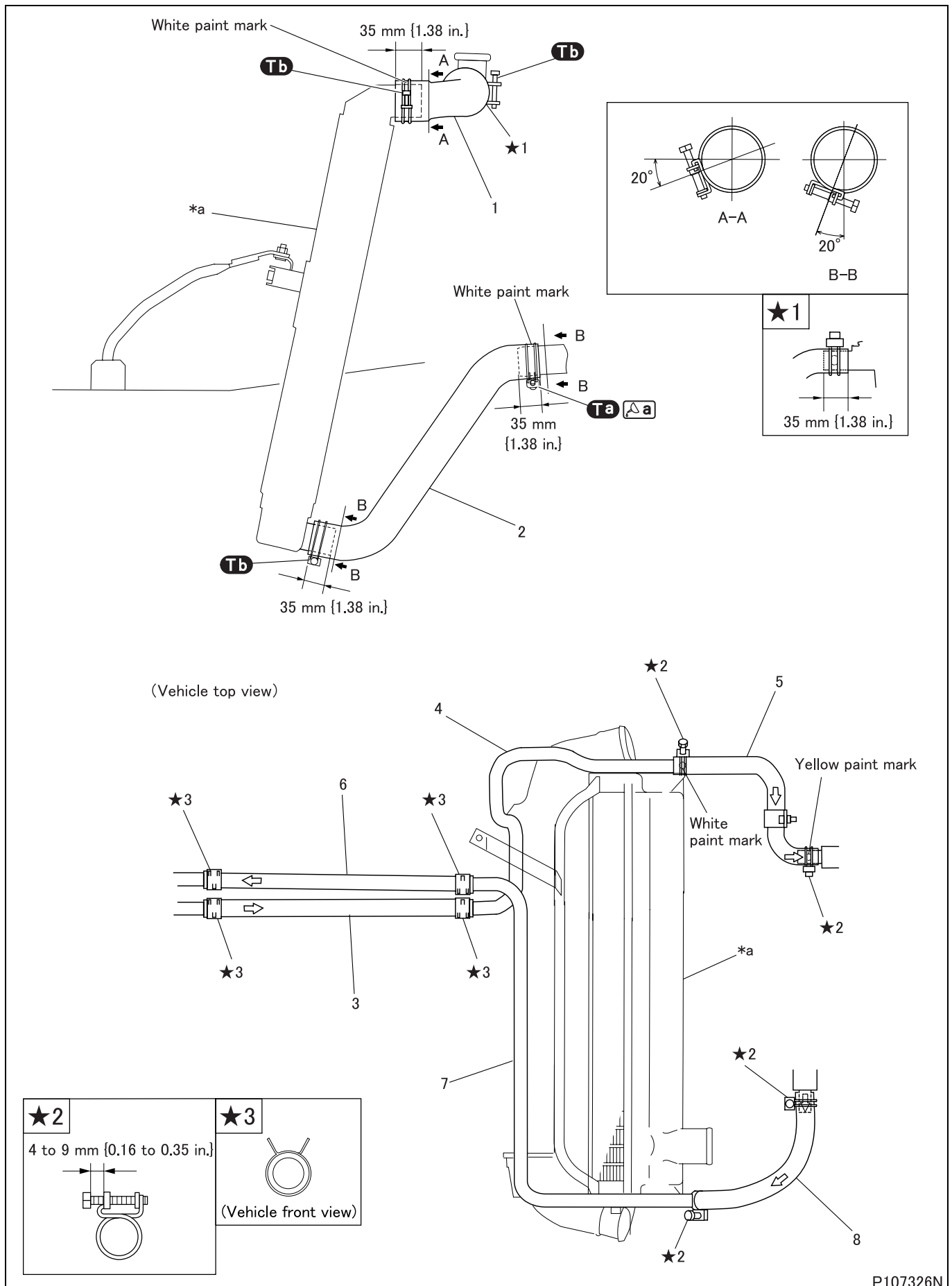

P107326N

(Engine right side view)

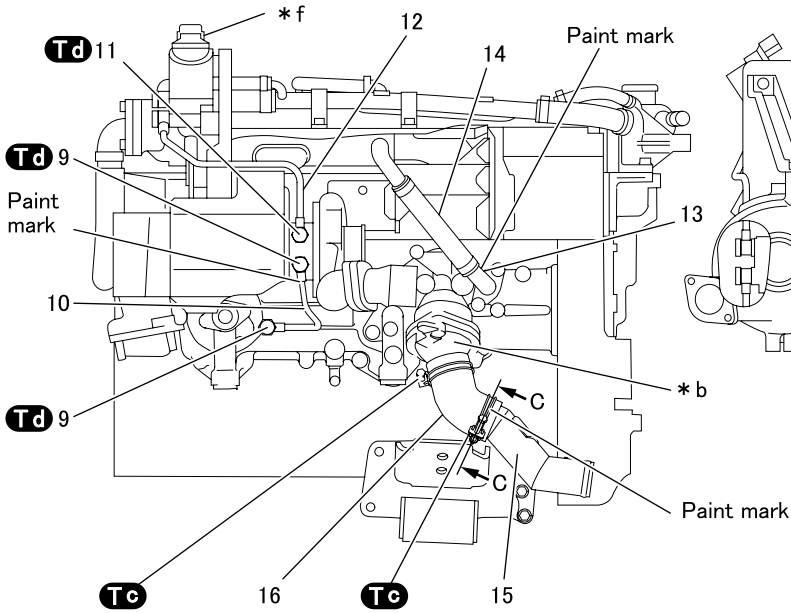

(Engine front view)

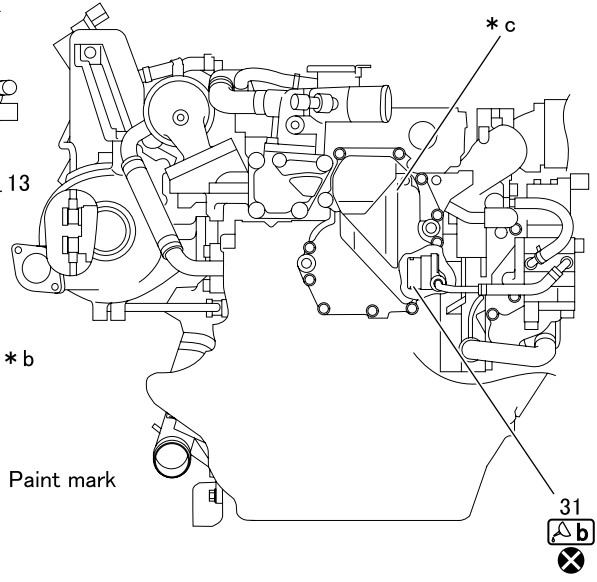

(Engine top view)

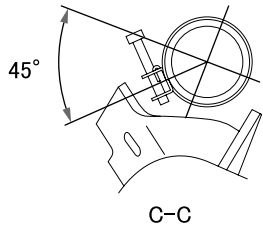
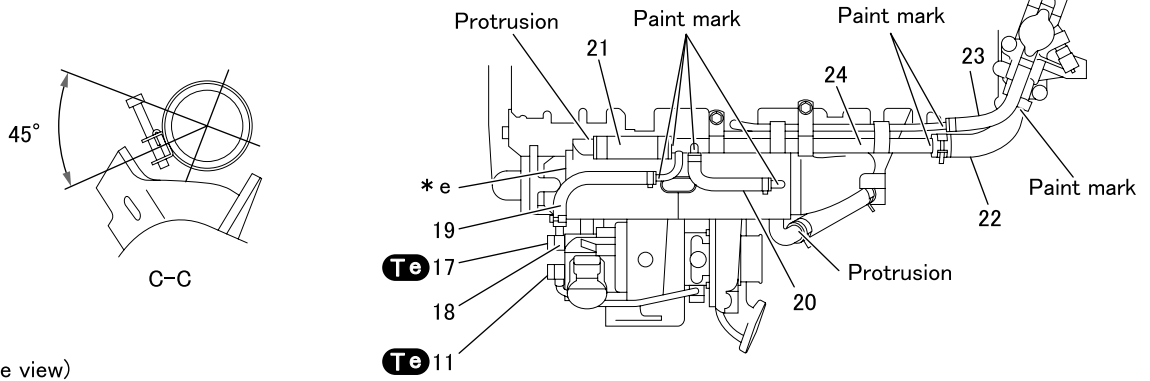

(Engine left side view)

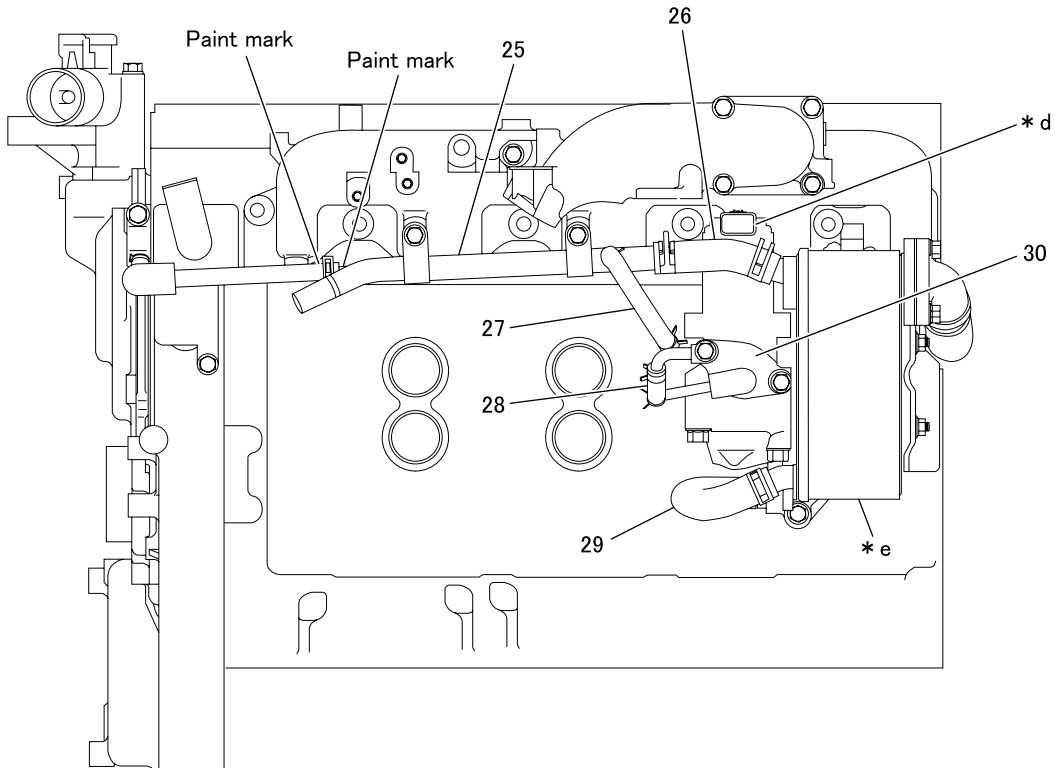

DISCONNECTION AND CONNECTION OF HOSES AND PIPES

● Removal sequence

- | | | |
|-----------------------------------------------|------------------------------------------------|--------------------------------------|
| 1 Upper radiator hose | 14 Water hose | 27 Water hose |
| 2 Lower radiator hose | 15 Water pipe | 28 Water hose |
| 3 Heater hose | 16 Water hose | 29 Water-in hose |
| 4 Heater pipe | 17 Eyebolt | 30 Adapter |
| 5 Heater hose | 18 Joint swivel | 31 O-ring |
| 6 Heater hose | 19 Water hose | |
| 7 Heater pipe | 20 Water hose | *a: Radiator |
| 8 Heater hose | 21 Water hose | *b: Thermostat cover |
| 9 Eyebolt | 22 Water hose | *c: Breather cover |
| 10 Water pipe | 23 Water hose | *d: Exhaust gas recirculation valve |
| 11 Eyebolt | 24 Water exhaust gas recirculation outlet pipe | *e: Exhaust gas recirculation cooler |
| 12 Water pipe | 25 Water pipe | *f: Turbocharger actuator |
| 13 Water exhaust gas recirculation inlet pipe | 26 Water-out hose | ⊗: Non-reusable parts |

● Installation sequence

Follow the removal sequence in reverse.



CAUTION

- Install each hose clamp to the angle indicated in the illustration so that sufficient clearance is assured between the hose clamp and its surrounding parts.
- Keep the O-ring free of engine oil. Engine oil will make the O-ring swell, which may cause leakage.

Tightening torque (Unit: N·m {lbf·ft, kgf·m})

Mark	Parts to be tightened	Tightening torque	Remarks
Ta	Clamp	1.5 to 2.0 {1.1 to 1.5, 0.15 to 0.2}	Wet
Tb	Clamp	3.0 to 4.5 {2.2 to 3.3, 0.3 to 0.5}	–
Tc	Clamp	4 {3.0, 4.0}	–
Td	Eyebolt (water pipe mounting)	26 {19, 2.7}	–
Te	Eyebolt (water pipe mounting)	21 {15, 2.1}	

Lubricant and/or sealant

Mark	Points of application	Specified lubricant and/or sealant	Quantity
 a	Clamp screw threads	Engine oil	As required
 b	O-ring	Soapy water	As required

◆ Installation procedure ◆

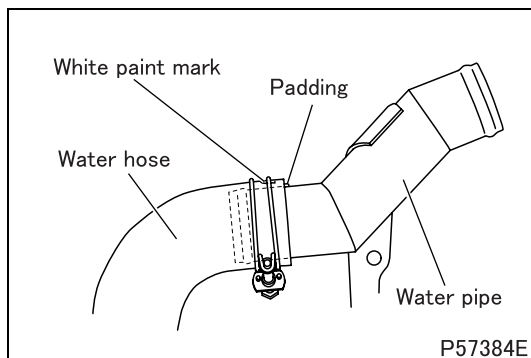

■ Installation: Water hose

- Install the water hose with the white mark on its end aligned with the padding on the water pipe.

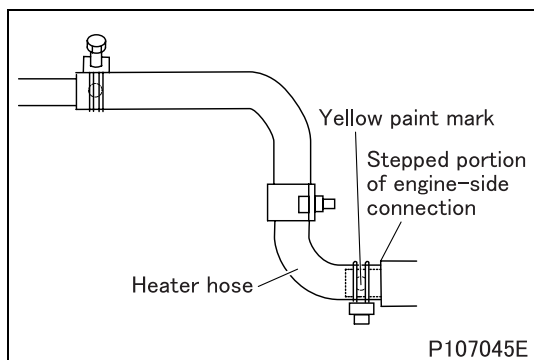

■ Installation: Heater hose

- To install the heater hose with a yellow paint mark to the engine-side connection, slide the hose over the connection until it seats to the stepped portion.

RADIATOR, FAN SHROUD

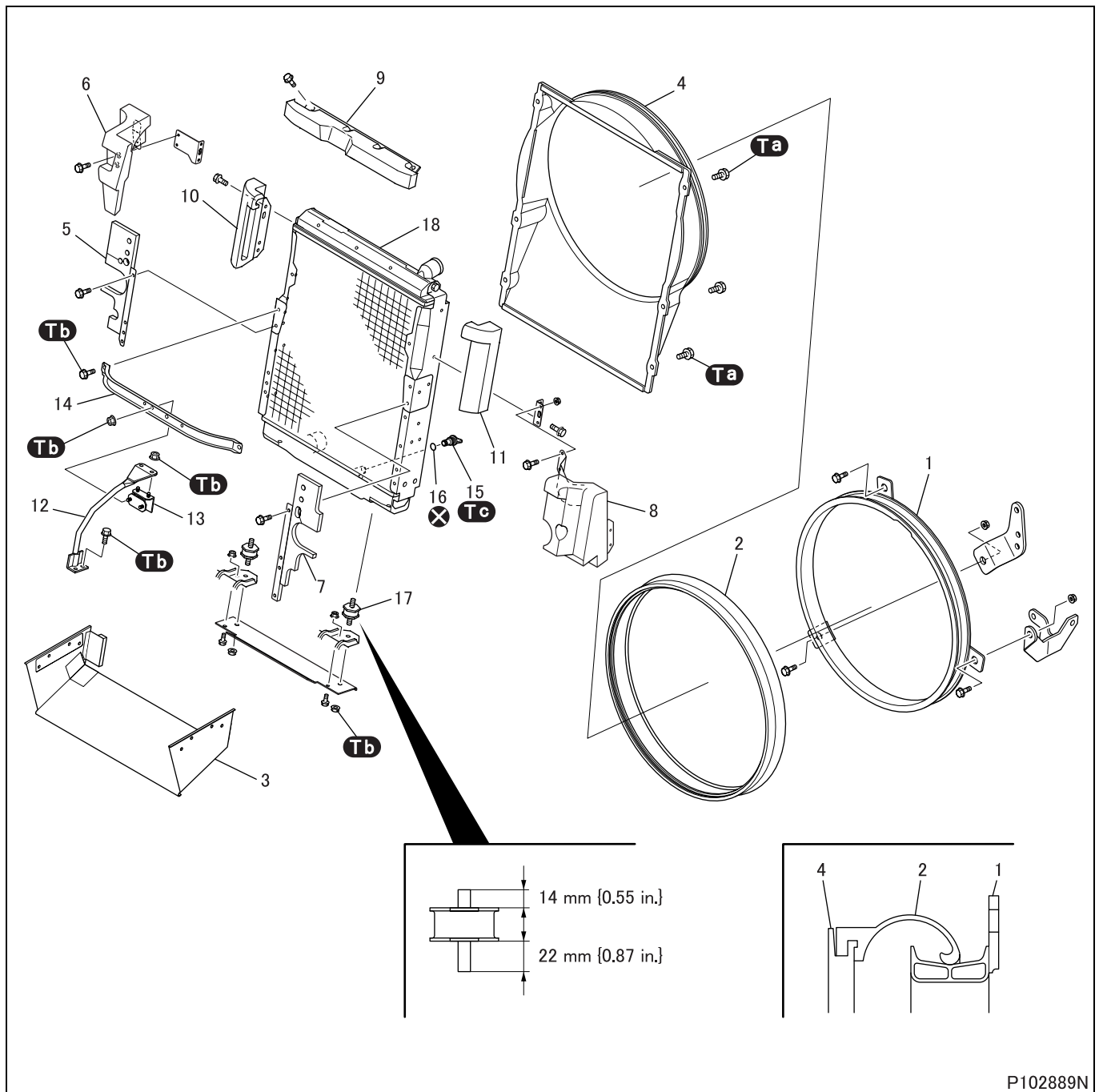

P102889N

● Removal sequence

- | | | |
|-------------------|----------------------|-------------------------------------|
| 1 Fan shroud | 8 Baffle plate LH | 15 Radiator drain cock |
| 2 Shroud seal | 9 Baffle plate upper | 16 O-ring |
| 3 Air scoop | 10 Baffle plate RH | 17 Support cushion |
| 4 Radiator shroud | 11 Baffle plate LH | 18 Radiator
(See later section.) |
| 5 Baffle plate RH | 12 Support rod | |
| 6 Baffle plate RH | 13 Support cushion | |
| 7 Baffle plate LH | 14 Upper support | ⊗ Non-reusable parts |

● Installation sequence

Follow the removal sequence in reverse.

Tightening torque (Unit: N·m {ft.lbs, kgf·m})

Mark	Parts to be tightened	Tightening torque	Remarks
Ta	Bolt (upper shroud mounting)	5 to 7 {3.7 to 5.2, 0.5 to 0.7}	-
	Bolt (lower shroud mounting)		
Tb	Bolt (support rod mounting)	12 to 15 {8.9 to 11, 1.18 to 1.47}	-
	Nut (support cushion mounting)		
	Bolt (upper support mounting)		
	Nut (support cushion mounting)		
Tc	Radiator drain cock	2.5 ± 0.5 {1.8 ± 0.4, 0.25 ± 0.05}	-

Special tools (Unit: mm {in.})

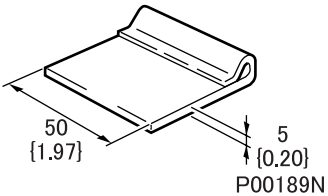
Mark	Tool name and shape	Part No.	Application
Ca	Tip clearance spacer 	MC019470	Adjusting clearance between fan shroud and cooling fan

◆ **Installation procedure** ◆

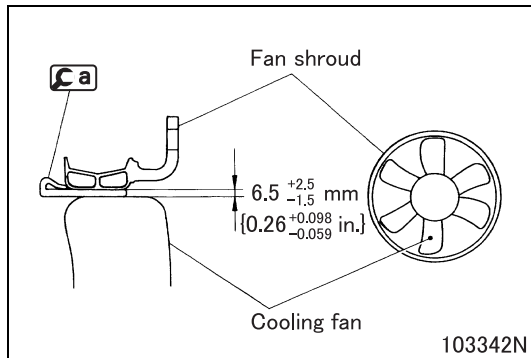

■ **Installation: Fan shroud**

- Using **Ca**, adjust the clearance between the fan shroud and cooling fan blades to the dimension shown in the illustration.

RADIATOR, FAN SHROUD

Radiator

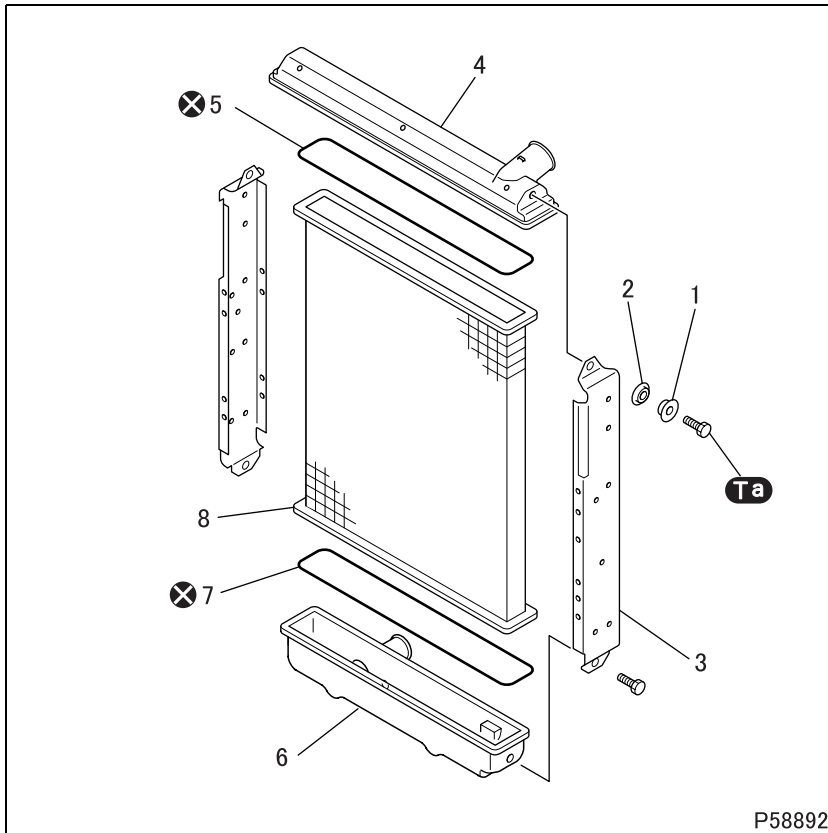

● Disassembly sequence

- 1 Pipe
- 2 Bush
- 3 Side member
- 4 Upper tank
- 5 Packing
- 6 Lower tank
- 7 Packing
- 8 Core

⊗: Non-reusable parts

CAUTION

- Do not disassemble the radiator unless defects are evident.
- Handle the upper tank and lower tank carefully, as they are made of plastic and may crack under impact.
- Check the number of paint marks put near the upper tank and lower tank mounting tabs. The number of paint marks corresponds to the number of times the tabs have been unbent and re-clinched. If the core has already two paint marks, replace it with a new one.

● Assembly sequence

Follow the disassembly sequence in reverse.





Service standards

Location	Maintenance item	Standard value	Limit	Remedy
-	Air leakage from radiator (air pressure 147 kPa {21 psi, 1.47 kgf/cm ² })	0 cm ³ {0 mL}	-	Repair or replace

Tightening torque (Unit: N·m {ft.lbs, kgf·m})

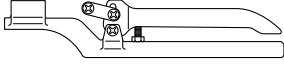
Mark	Parts to be tightened	Tightening torque	Remarks
Ta	Bolt (side member mounting)	13 {9.6, 1.3}	-

Special tools

Mark	Tool name and shape	Part No.	Application
	Overhaul handle  P51240	MH062875	Installation and removal of upper tank and lower tank
	Claw  P51241	MH062876	
	Punch assembly  P51242	MH062877	

◆ **Inspection before removal** ◆

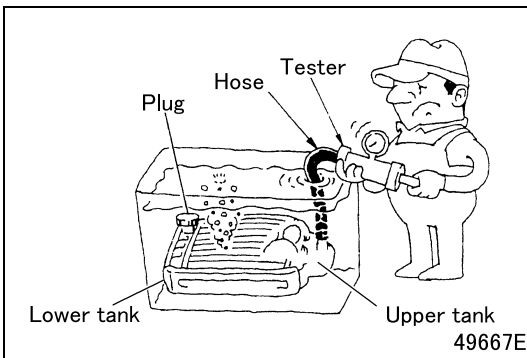

■ **Inspection: Radiator air leakage**

- Connect a hose and radiator cap tester to the upper tank.
- Plug the lower tank and put the entire radiator into a tank filled with water.
- If air leakage is found, repair or replace the radiator.
- Apply a specified air pressure using radiator cap tester, and check for any air leakage.

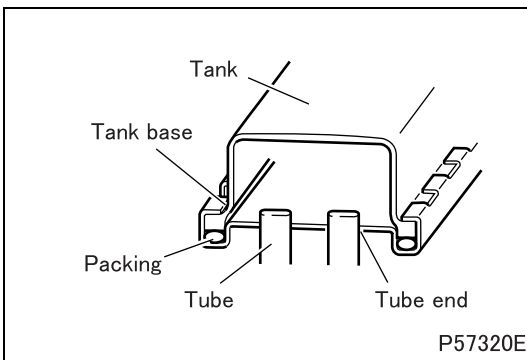

- Replace the following parts according to the area of leakage.

Area of leakage		Cause
Upper tank Lower tank	Tank body	Cracks in tank
	Tank base	Defective tabs Defective packing Cracks in tank
Tube body, tube ends		Cracks in tube

RADIATOR, FAN SHROUD

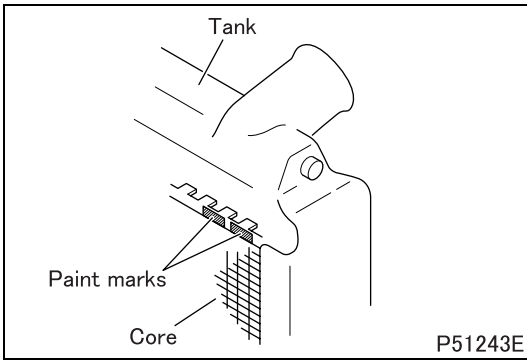

NOTE

- The core may have paint marks that indicate the number of times the upper tank and lower tank mounting tabs have been unbent and re-clinched. Replace the core if it has already two paint marks.
- One paint mark is made every time the tabs are unbent and re-clinched. Upper tank paint marks should be counted separately from lower tank paint marks.

◆ Removal procedure ◆

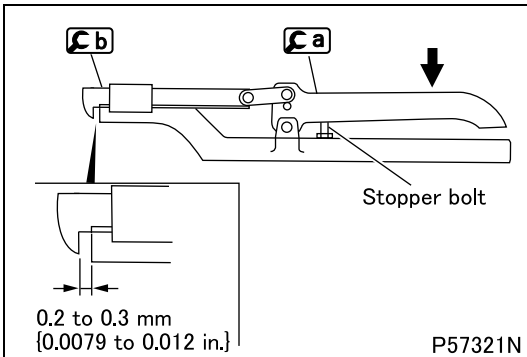

■ Removal: Upper tank and lower tank

- Attach **C b** onto **C a**.
- Using the stopper bolt on **C a**, adjust the jaw span of **C b** to the dimension indicated in the illustration.

CAUTION ⚠

- **Make sure to adjust the stopper bolt before using the tools. Failure to do so may cause damage to **C b**.**

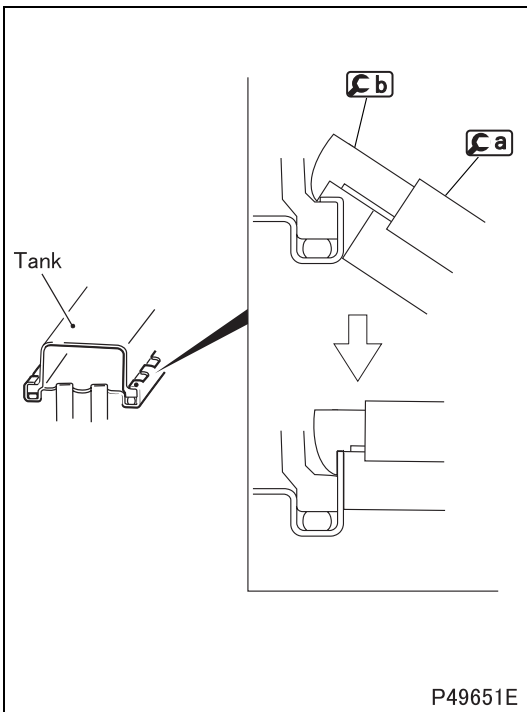

- Using **C b**, undo the tabs that are holding the tank in place.
- Once each tab is unbent, grip **C a** more tightly to straighten it out completely.
- Undo all the tabs on the entire periphery of the tank, then remove the tank using the inlet hose fitting as a grip.

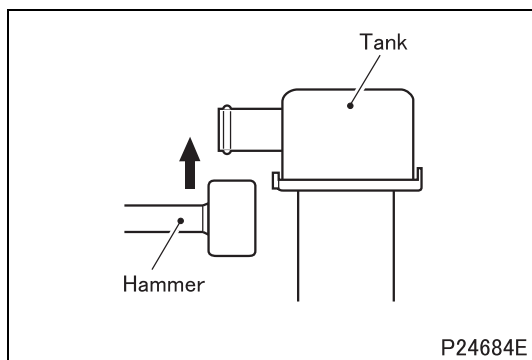

- If the tank does not come off easily, tap it lightly with a soft-face hammer (rubber or plastic hammer) to loosen it.

CAUTION ⚠

- Handle the tanks carefully, as they are made of plastic and may crack easily under impact.

◆ Inspection procedure ◆

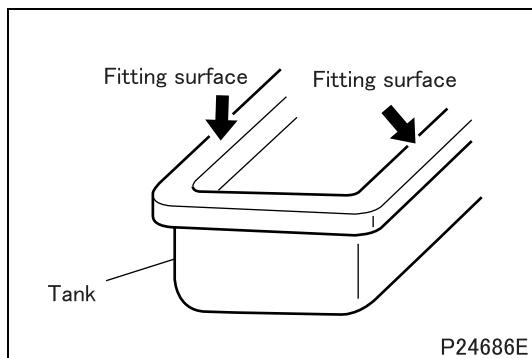

■ Inspection: Core fitting surfaces of tank

- Inspect the core fitting surfaces of the tank for any dirt or damage. If necessary, clean them thoroughly.
- Replace the tank(s) if defective.

CAUTION ⚠

- Carry out the inspection with your bare hands to avoid putting foreign matter on the fitting surfaces.

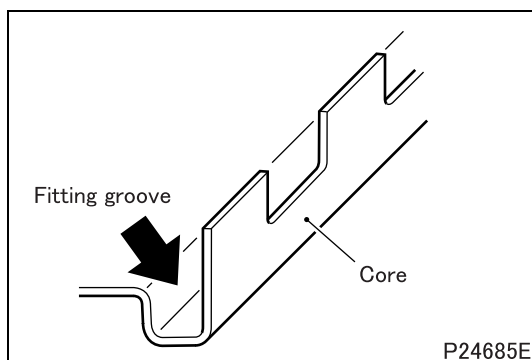

■ Inspection: Tank fitting groove of core

- Check the tank fitting groove of the core for any foreign matter or cracks.
- If foreign matter is found on the groove surfaces, lightly scrub it off with a No.1000 sandpaper taking care not to damage the surfaces, or blow it off with compressed air.
- If a crack is found on the groove surfaces, repair the crack or replace the core.

CAUTION ⚠

- Installing a packing and tank on the core without removing foreign matter from the groove surfaces can lead to coolant leakage. Make sure to inspect the entire groove surfaces extremely carefully. Even one strand of hair is enough to cause leakage.

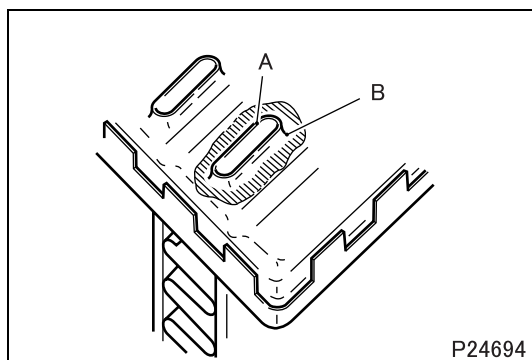

Repair of core

CAUTION ⚠

- The following core repair procedure involves tungsten inert gas arc welding (TIG arc welding). Only personnel competent for doing this type of welding should carry out the job.
- Dry the core completely before performing welding. Welding wet parts could be extremely dangerous.

- Scrub both ends **A** of a leaky tube as well as the surrounding areas **B** of each end with a stainless wire brush. Continue scrubbing until the aluminum layer becomes exposed.

RADIATOR, FAN SHROUD

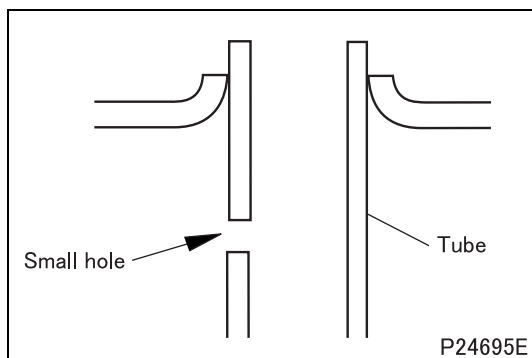

- Drill a small hole in the tube to let the air out when both ends of the tube are welded closed.

CAUTION

Failure to drill an air release hole in the tube may cause pinholes to form in the welds.

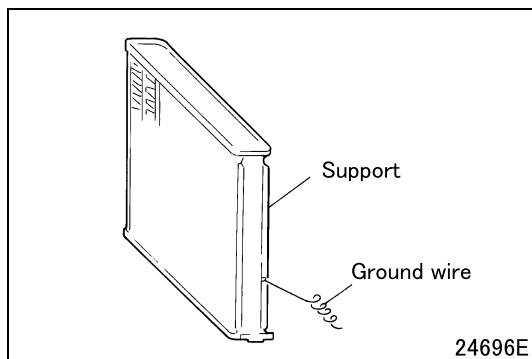

- Connect one of the support edges of the core to ground with a wire.

CAUTION

- **Inadequate connection of the ground wire can cause a short circuit to a part of the core, which may cause the part to melt.**

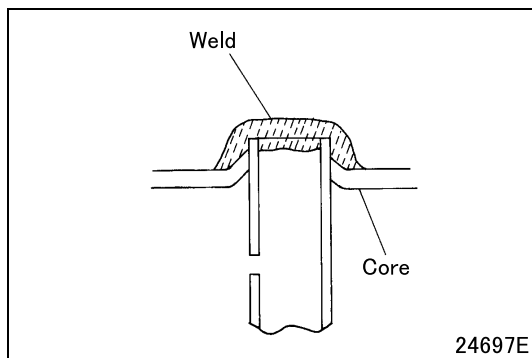

- Close both ends of the tube by TIG arc welding.
 - Welding conditions
 - Welding rod: A4043 (diameter approximately 2 mm { ϕ 0.079 in.})
 - Welding current: AC80A
- After the welding is completed, check for the following defects. If any of these defects are spotted, repair the defect or replace the core.
 - Undercuts
 - Cracks in weld bead
 - Cracks in base metal

CAUTION

- **Make sure that welds are proper. Any defect in welding can lead to recurrence of leakage.**

◆ Installation procedure ◆

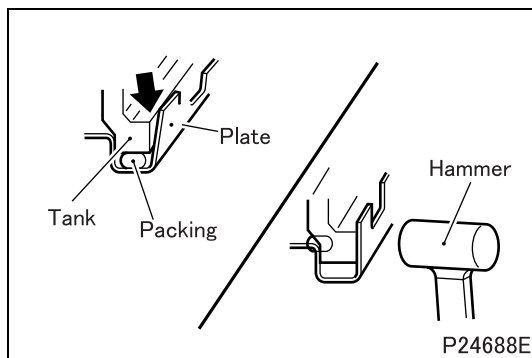

■ Installation: Upper tank and lower tank

- If there is a gap between the tank and core's tank holding plate when the tank is placed in position, lightly tap the plate with a rubber or plastic hammer to eliminate the gap.

CAUTION

- **When installing the tank and packing, use your bare hands to avoid putting foreign matter on the parts.**

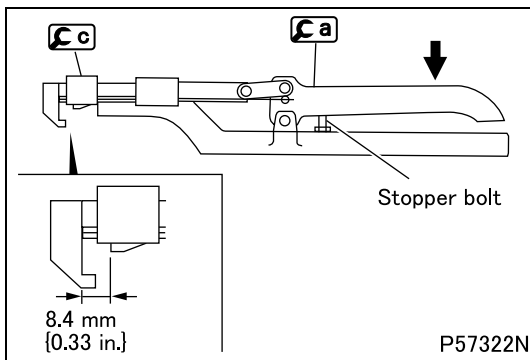

- Attach **Cc** onto **Ca**.
- Using the stopper bolt on **Ca**, adjust the jaw span of **Cc** to the dimension indicated in the illustration.

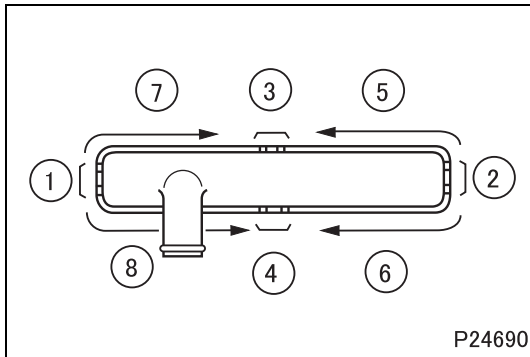

- Bend and clinch the tabs of the core over the brim of the tank in the sequence indicated in the illustration.
1 to 4: Clinch the two tabs at the center on each side of the tank.
5 to 8: Clinch the rest of the tabs in the order indicated by the arrows.

CAUTION ⚠

- The tabs on sides 1 and 2 cannot be clinched using **Cc**. Use a pair of pliers with the noses wrapped with vinyl tape to clinch these tabs.

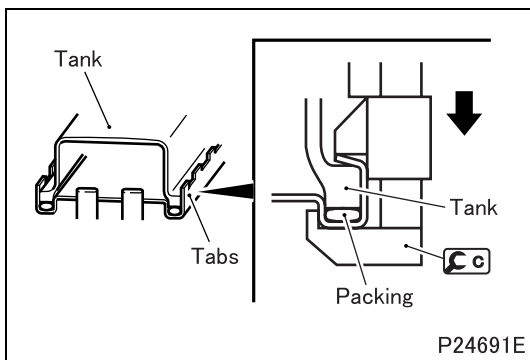

- After clinching all the tabs, check for leakage.

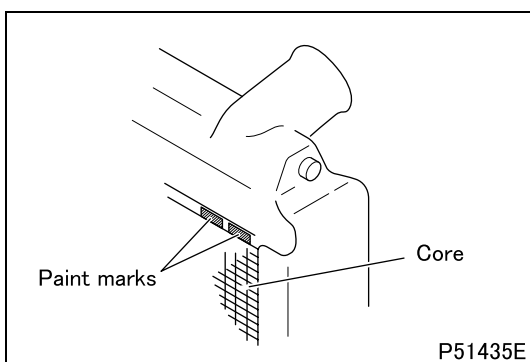

- Put a paint mark on a clearly visible area of the core to indicate the number of times the tabs have been unbent and re-clinched.

CAUTION ⚠

- One paint mark should be made for each of the upper and lower tanks every time the tabs for it are unbent and re-clinched.

COOLING FAN, V-BELT AND WATER PUMP

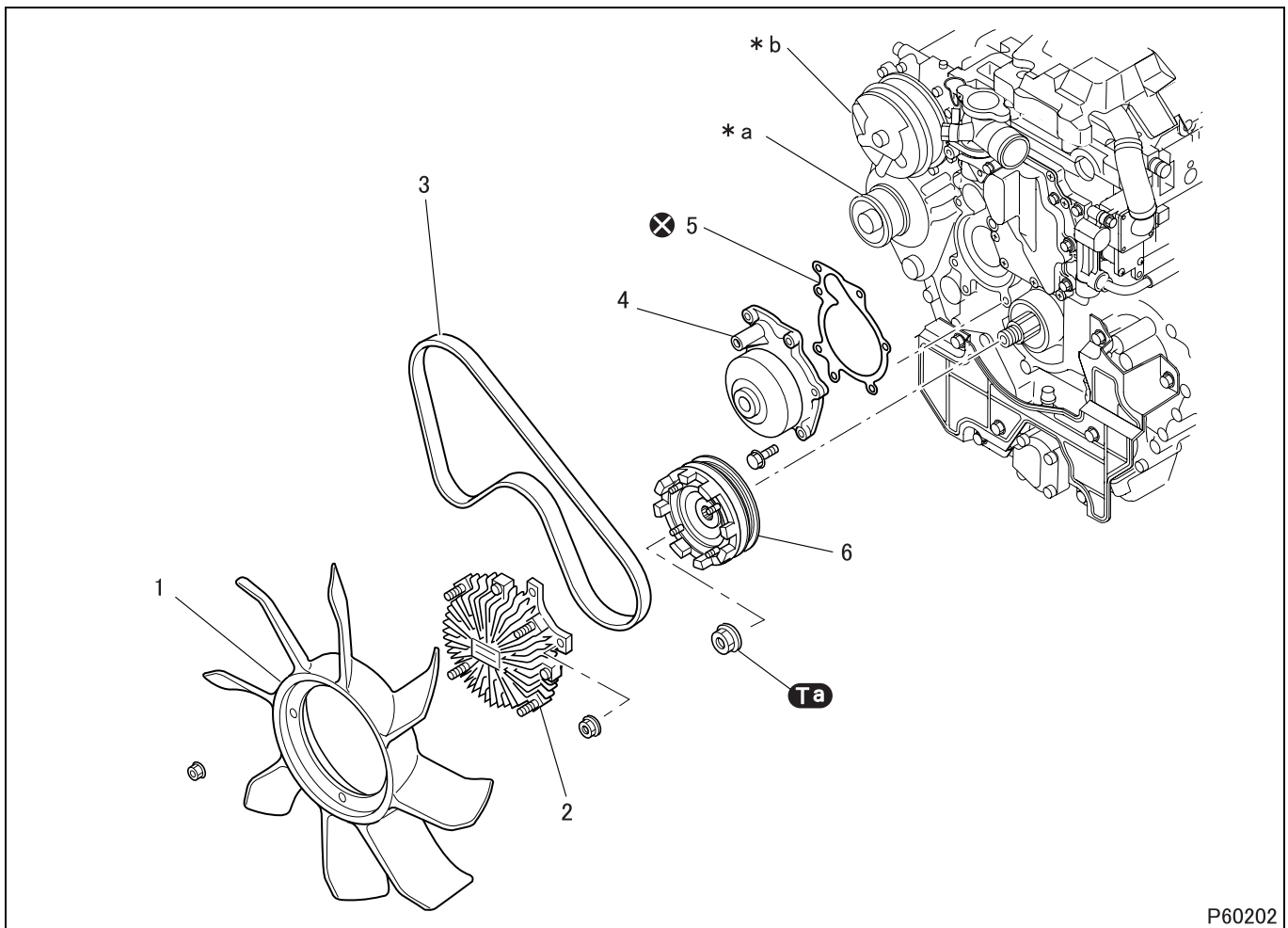

P60202

● Removal sequence

- | | |
|----------------------------------|--------------|
| 1 Cooling fan | 4 Water pump |
| 2 Automatic cooling fan coupling | 5 Gasket |
| 3 V-belt | 6 Fan pulley |

- *a: Alternator
 *b: Compressor
 <With air conditioner>
 Tension pulley
 <Without air conditioner>

⊗: Non-reusable parts

● Installation sequence

Follow the removal sequence in reverse.

CAUTION

- The automatic cooling fan coupling and the water pump cannot be disassembled. It must be replaced if defective.
- Make sure that there is no oil or grease on the V-belts. V-belts soiled with oil or grease may easily slip, resulting in deteriorated performance of the cooling system.

Tightening torque (Unit: N·m {ft.lbs, kgf·m})

Mark	Parts to be tightened	Tightening torque	Remarks
Ta	Nut (fan pulley mounting)	370 {270, 38}	—

Special tools (Unit: mm {in.})

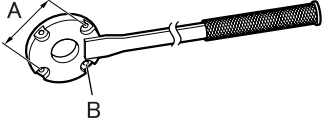
Mark	Tool name and shape	Part No.	Application				
Ca	Holding bar <table border="1"> <thead> <tr> <th>A</th> <th>B</th> </tr> </thead> <tbody> <tr> <td>114 {4.49}</td> <td>$\phi 9$ {$\phi 0.35$}</td> </tr> </tbody> </table>  P69433	A	B	114 {4.49}	$\phi 9$ { $\phi 0.35$ }	MH062970	Holding of fan pulley
A	B						
114 {4.49}	$\phi 9$ { $\phi 0.35$ }						

◆ Inspection and cleaning procedure ◆

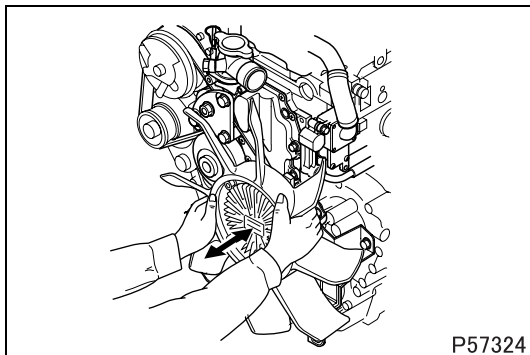

■ Inspection: Automatic cooling fan coupling

- Make an inspection of the following points. Replace the automatic cooling fan coupling if defective.
Check that:
 - the hydraulic oil sealed inside the coupling is not leaking;
 - the coupling does not make any abnormal noise or rotate unevenly due to defects in the inside bearing when rotated manually; and
 - the automatic cooling fan coupling does not move too much when pushed and pulled in the axial directions when the engine is cold.

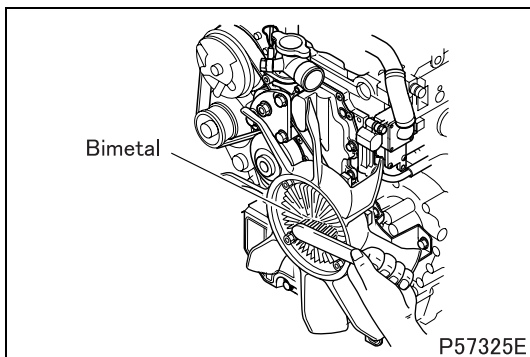

■ Cleaning: Automatic cooling fan coupling

- When removing foreign matter from the bimetal, be careful not to press too hard against the bimetal.

◆ Removal procedure ◆

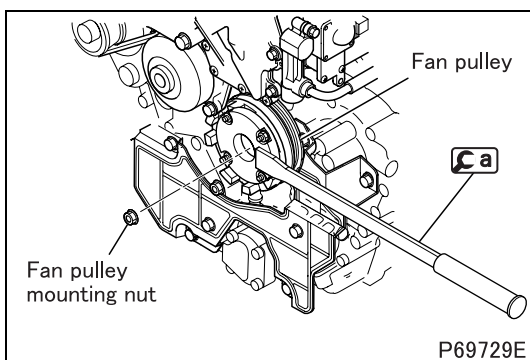

■ Removal: Fan pulley

- Put **Ca** in position on the studs of the fan pulley and fix the tool by using nuts.
- While holding **Ca**, loosen the fan pulley mounting nut.

COOLING FAN, BELT AND WATER PUMP

◆ Installation procedure ◆

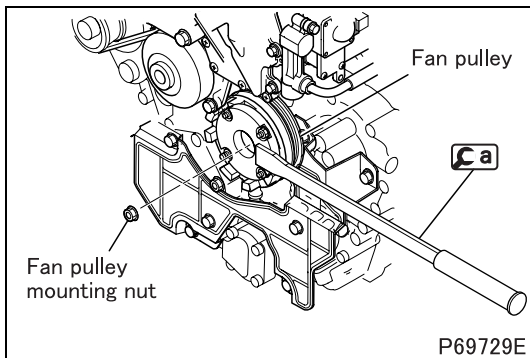

■ Installation: Fan pulley

- Put **Ca** in position on the studs of the fan pulley and fix the tool by using nuts.
- Tighten the fan pulley mounting nut to the specified torque while holding **Ca**.

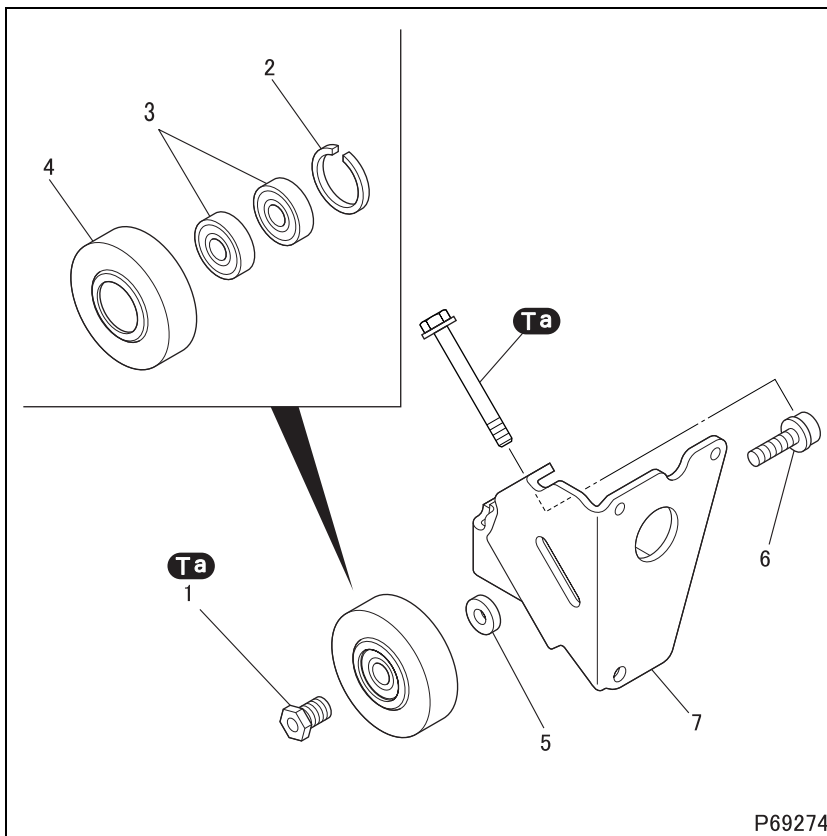

● Disassembly sequence

- 1 Sleeve
- 2 Snap ring
- 3 Bearing
- 4 Tension pulley
- 5 Spacer
- 6 Shaft
- 7 Tension pulley bracket

● Assembly sequence

Follow the disassembly sequence in reverse.

Tightening torque (Unit: N·m {lbf·ft, kgf·m})

Mark	Parts to be tightened	Tightening torque	Remarks
Ta	Sleeve	15 {11, 1.5}	—

THERMOSTAT

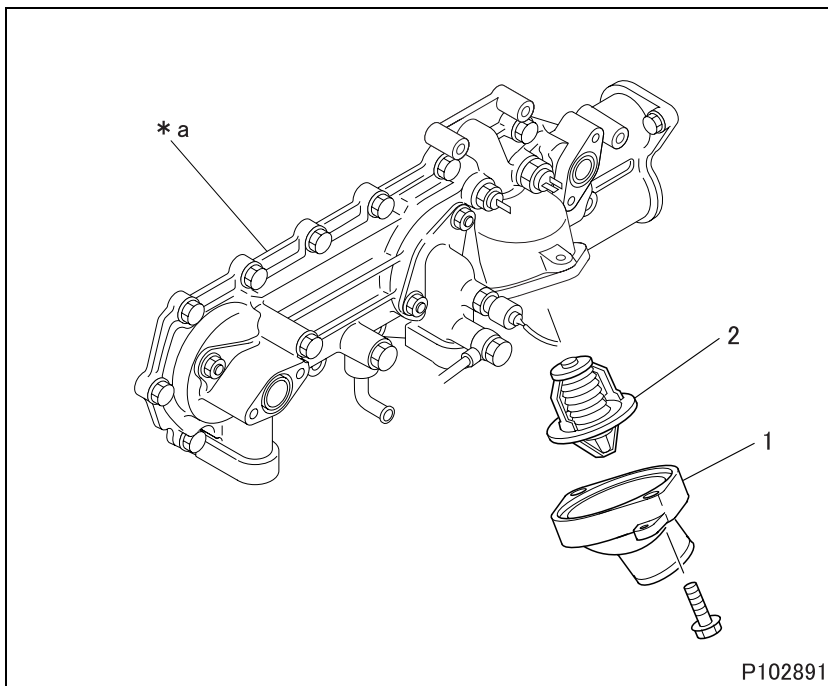

● Disassembly sequence

- 1 Thermostat cover
- 2 Thermostat

*a: Oil cooler

● Assembly sequence

Follow the disassembly sequence in reverse.

P102891

Service standards (Unit: mm {in.})

Location	Maintenance item	Standard value	Limit	Remedy	
2	Thermostat	Valve opening temperature	$82 \pm 2^{\circ}\text{C}$ { $180 \pm 3.6^{\circ}\text{F}$ }	-	Replace
		Valve lift / temperature	10 {0.39} or more / 95°C { 205°F }		

◆ Inspection procedure ◆

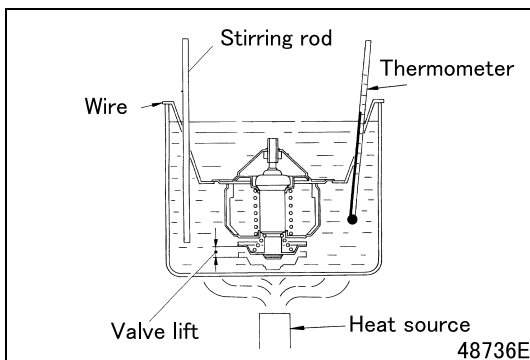

■ Inspection: Thermostat

- Stir the water using a stirring rod to maintain an even water temperature in the container, then conduct the tests indicated below.
- If the measured values deviate from the standard value ranges, replace the thermostat.

(1) Valve opening temperature

- Hold the thermostat with wire to keep it away from the heat source.
- Heat the water gradually to the valve opening temperature.
- Maintain this temperature for five minutes and make sure that the valve is completely open.
- Make sure that the valve closes completely when the water temperature drops below 65°C { 150°F }.

(2) Valve lift

- Heat the water to a temperature slightly higher than the valve opening temperature. Maintain this temperature for five minutes and measure the valve lift.

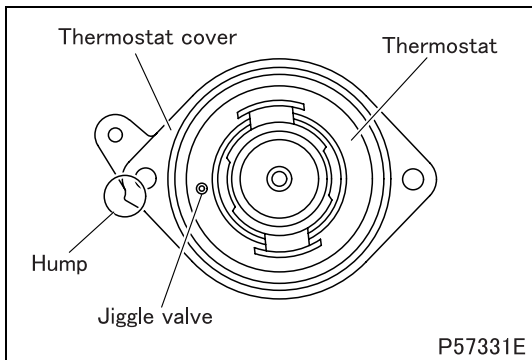
◆ Installation procedure ◆**■ Installation: Thermostat**

- Mount the thermostat on the thermostat cover in the illustrated direction.

PRESSURE CAP AND WATER OUTLET CASE

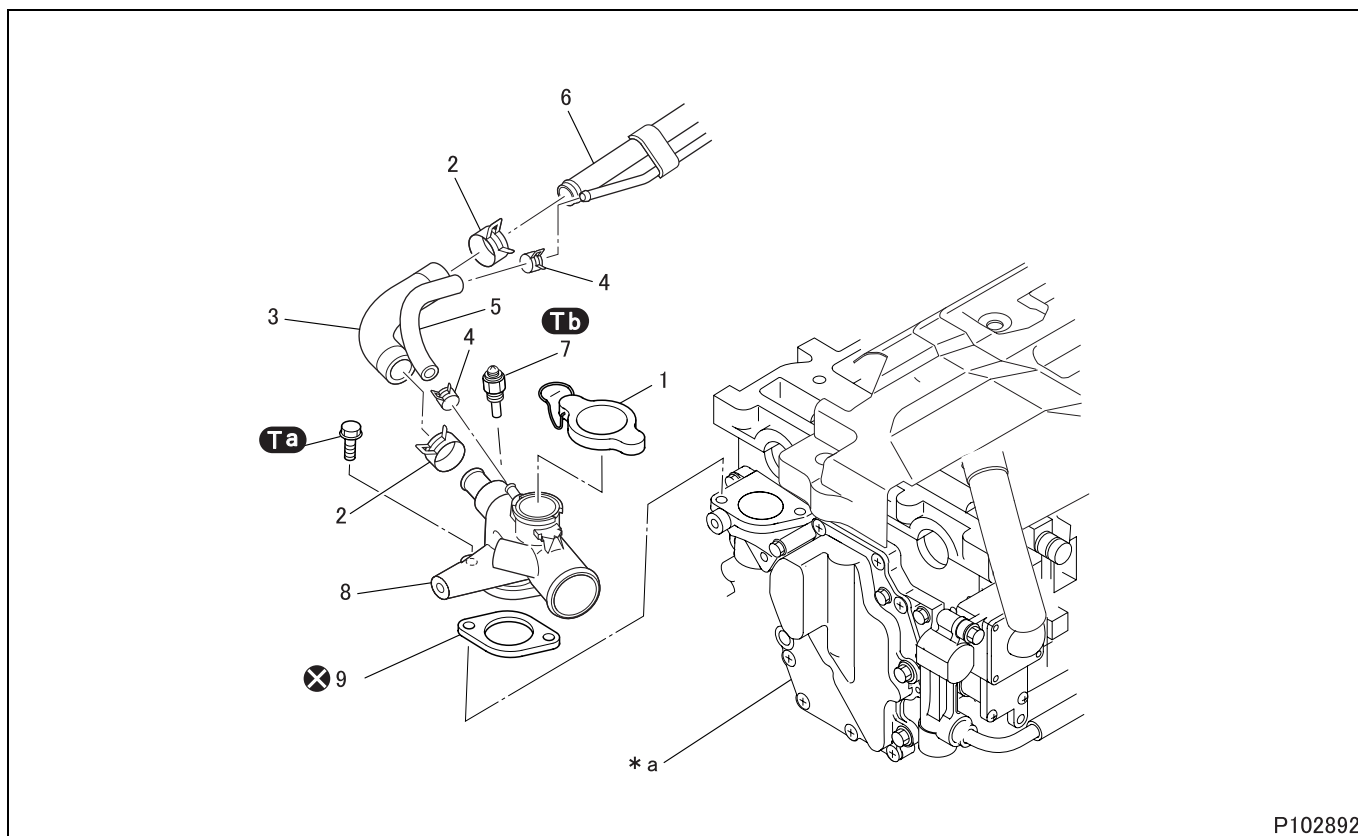

P102892

● Disassembly sequence

- | | | |
|----------------|-----------------------------------------|-----------------------|
| 1 Pressure cap | 5 Water hose | 8 Water outlet case |
| 2 Clip | 6 Exhaust gas recirculation outlet pipe | 9 Gasket |
| 3 Water hose | 7 Overheating switch | *a: Breather cover |
| 4 Clip | | ⊗: Non-reusable parts |

● Assembly sequence

Follow the disassembly sequence in reverse.

Service standards

Location	Maintenance item	Standard value	Limit	Remedy
1	Pressure cap valve opening pressure	110 ± 15 kPa {16 ± 2.2 psi, 1.1 ± 0.15 kgf/cm ³ }	–	Replace

Tightening torque (Unit: N·m {lbf·ft, kgf·m})

Mark	Parts to be tightened	Tightening torque	Remarks
Ta	Bolt (water outlet case mounting)	24 {18, 2.4}	–
Tb	Overheating switch	35 {26, 3.6}	–

◆ Inspection procedure ◆

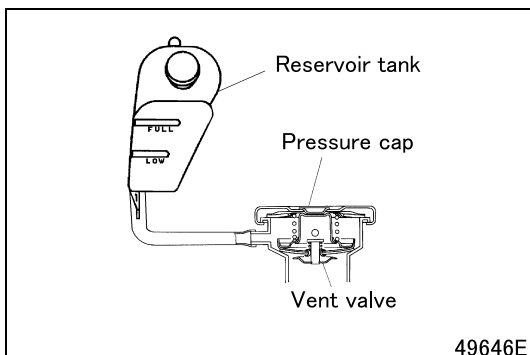
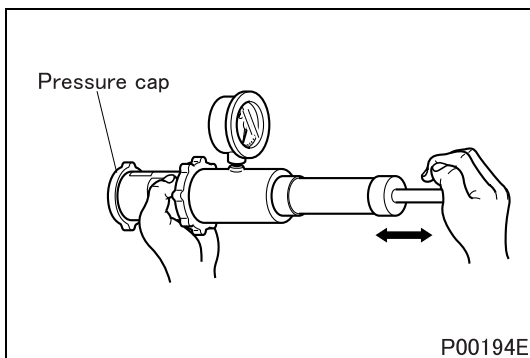

■ Inspection: Pressure cap

(1) Pressure valve opening pressure

- Replace the pressure cap if the measured value deviates from the standard value range.

(2) Inspection of vent valve

- Before starting the inspection, check the level of coolant in the reservoir tank.
- Run the engine at full speed. Stop the engine when the level of coolant in the reservoir tank noticeably rises.
- Wait until the coolant temperature drops to the ambient temperature. Then, check if the coolant in the reservoir tank has returned to the same level as that confirmed before the engine was started.
- If the coolant has failed to return to its original level, the vent valve is defective. In this case, replace the pressure cap.

CAUTION ⚠

- **Be aware that removing the pressure cap before the coolant cools down to the ambient temperature will result in loss of vacuum in the radiator, which disables the coolant from being returned to the reservoir tank.**