

---

# INDEX

<b>SPECIFICATIONS .....</b>	<b>15-2</b>
<b>STRUCTURE AND OPERATION</b>	
1. Air Cleaner.....	15-2
2. Turbocharger.....	15-3
3. Turbocharger Control System .....	15-4
4. Diesel Particulate Filter .....	15-8
<b>TROUBLESHOOTING.....</b>	<b>15-18</b>
<b>ON-VEHICLE INSPECTION AND ADJUSTMENT</b>	
1. Measurement of Turbocharger Boost Pressure.....	15-19
<b>AIR DUCT AND AIR CLEANER.....</b>	<b>15-20</b>
<b>DIESEL PARTICULATE FILTER INSPECTION .....</b>	<b>15-24</b>
<b>TURBOCHARGER .....</b>	<b>15-30</b>
<b>INTERCOOLER .....</b>	<b>15-34</b>
<b>INTAKE MANIFOLD .....</b>	<b>15-37</b>
<b>EXHAUST MANIFOLD .....</b>	<b>15-39</b>
<b>EXHAUST PIPE.....</b>	<b>15-40</b>
<b>DIESEL PARTICULATE FILTER .....</b>	<b>15-42</b>

# SPECIFICATIONS/STRUCTURE AND OPERATION

## SPECIFICATIONS

Item		Specifications
Air cleaner element		Filter paper type
Turbocharger	Model	TD04
	Manufacturer	Mitsubishi Heavy Industries, Ltd.
Intercooler		Tube and corrugated fin type air-to-air heat exchanger
DPF (Diesel Particulate Filter) type		Regeneration control type diesel particulate filter system

## STRUCTURE AND OPERATION

### 1. Air Cleaner

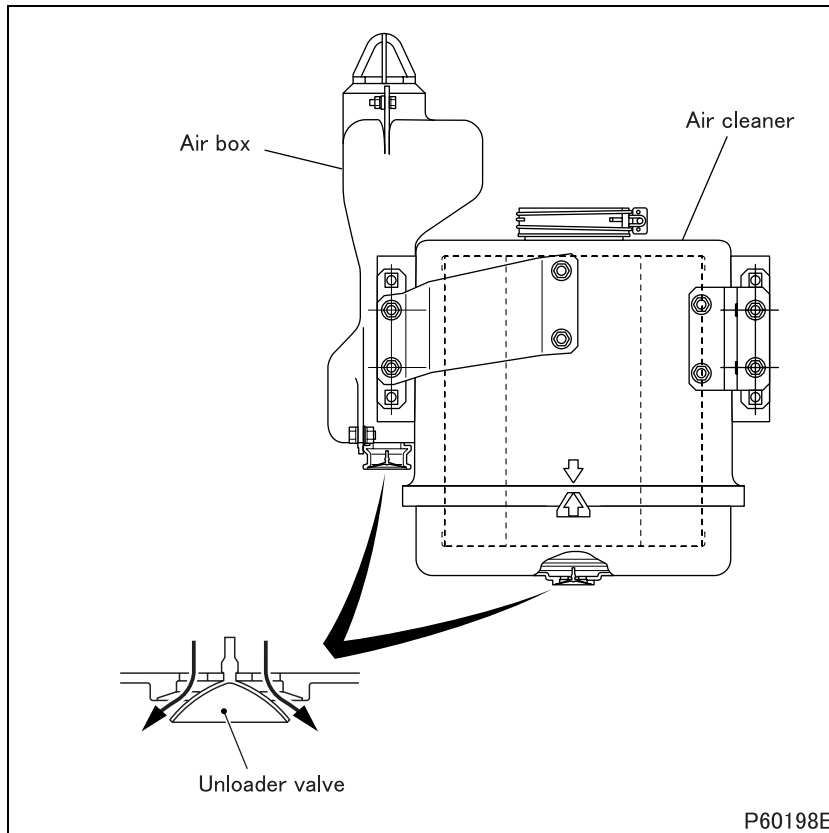

- The air cleaner is a single element type.
- When the engine slows down below the predetermined speed, the level of vacuum changes and causes the unloader valve to vibrate. Vibration of the unloader valve allows the air cleaner to automatically discharge any water and dust that has accumulated in its inside.

## 2. Turbocharger

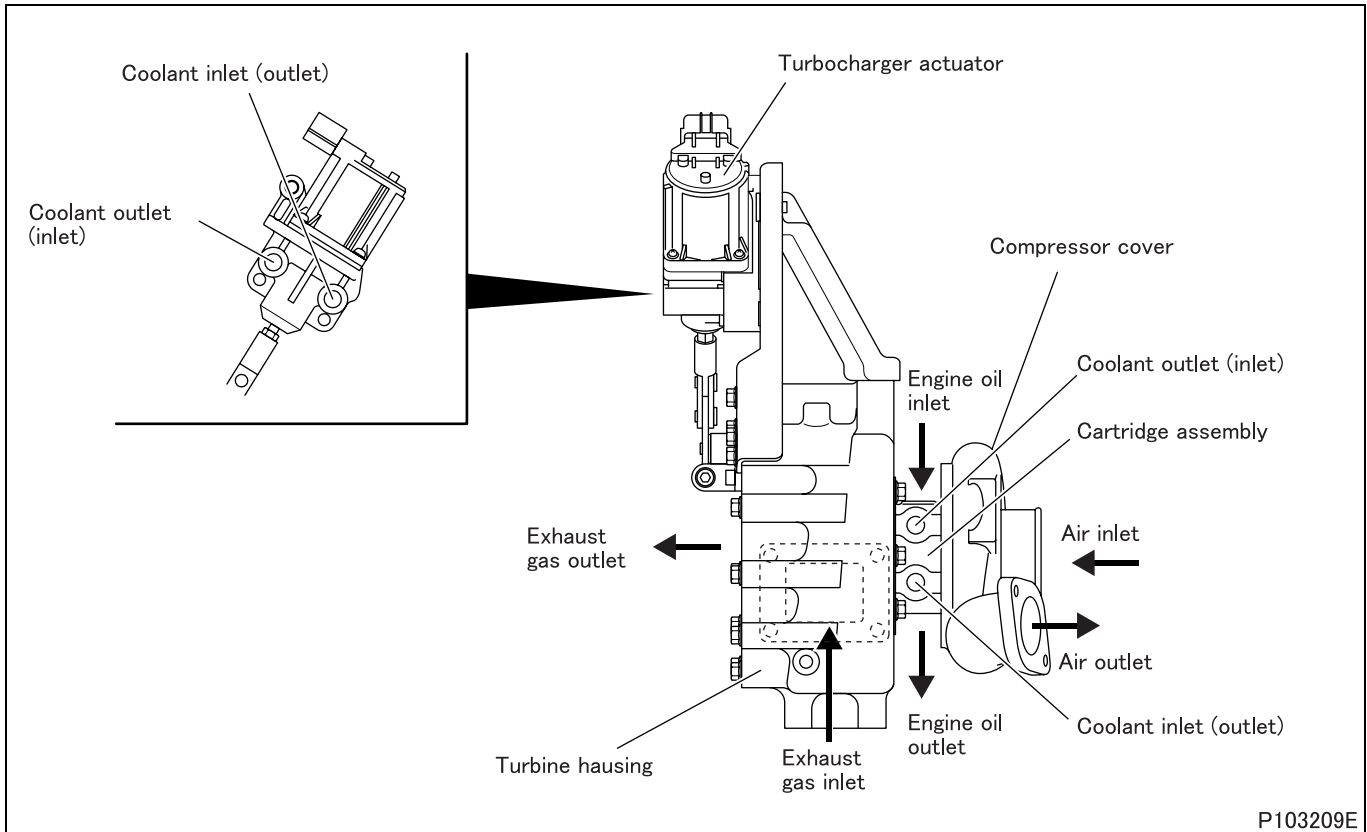

- TD05 model is equipped with turbocharger, which is a variable nozzle vane type turbocharger with adjustable, heat-resistive alloy turbine vanes provided at the turbine exhaust gas inlet port.

# STRUCTURE AND OPERATION

## 3. Turbocharger Control System

### 3.1 General description

- In the turbocharger control system, various engine-related information (engine speed, coolant temperature, accelerator position) and driving status are collected by the relevant sensors and are sent to the engine electronic control unit and turbocharger electronic drive unit which then control the engine based on the information received.
- The turbocharger actuator controls the opening of turbine vanes according to control signals to ensure low fuel consumption and high torque operation over the entire speed range.

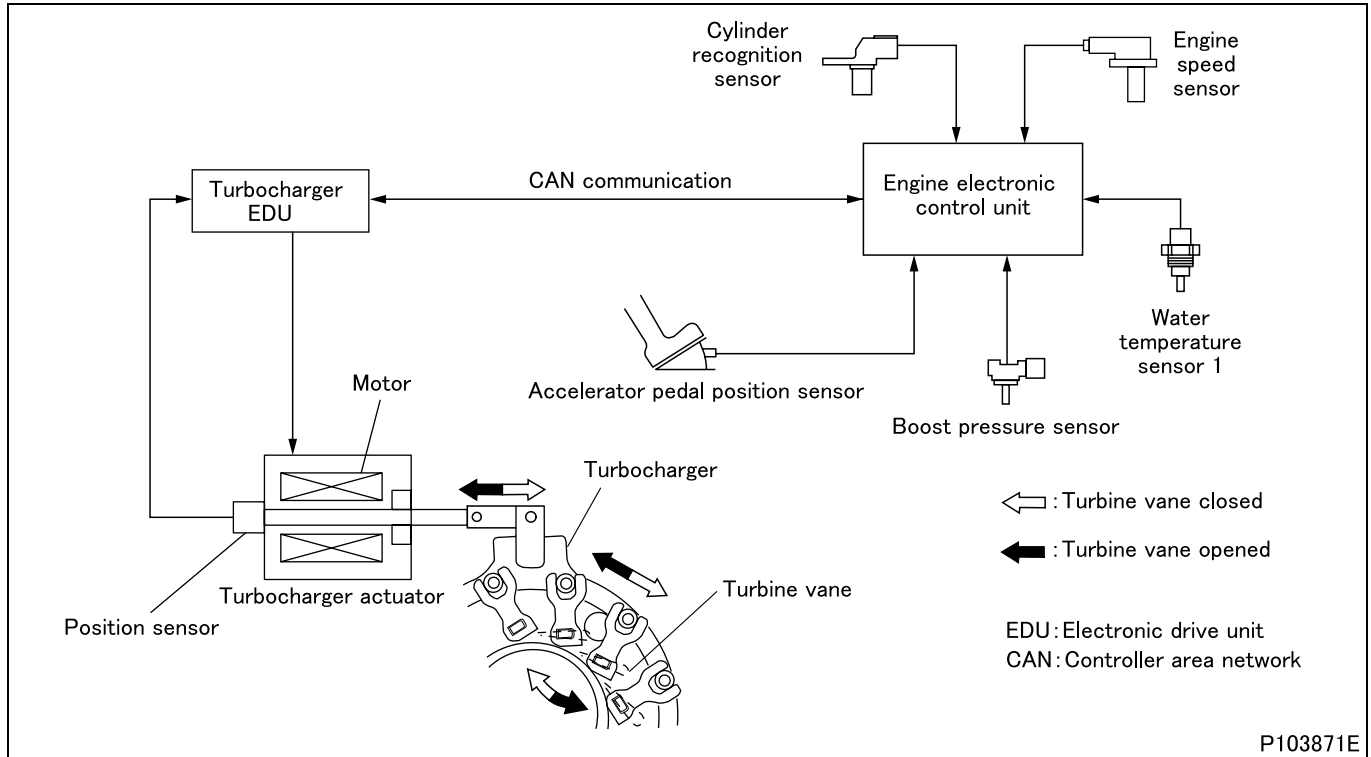

3.2 Electronic control system

(1) System block diagram

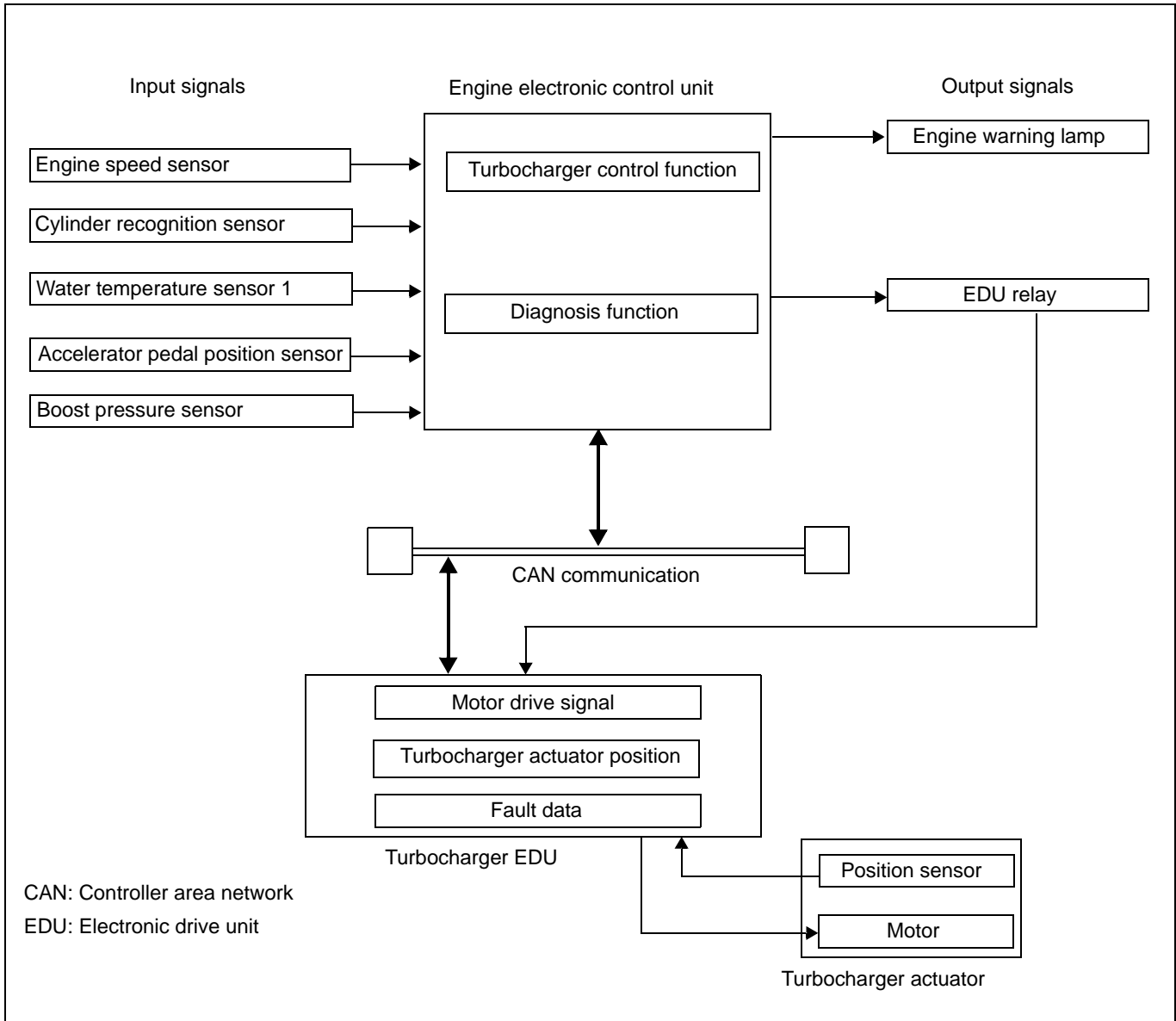

# STRUCTURE AND OPERATION

## (2) Turbocharger control function

- In response to output data from various sensors, the engine electronic control unit determines the opening of turbine vanes as required by the engine operating status and sends necessary control signals to the turbocharger electronic drive unit. (target opening of turbine vanes)
- The turbocharger electronic drive unit activates the turbocharger actuator motor to detect the amount of resultant shaft position by means of the position sensor and sends it to the engine electronic control unit. (actual opening of turbine vanes)

Thus, the target opening of turbine vanes can be accurately maintained as commanded by the engine electronic control unit.

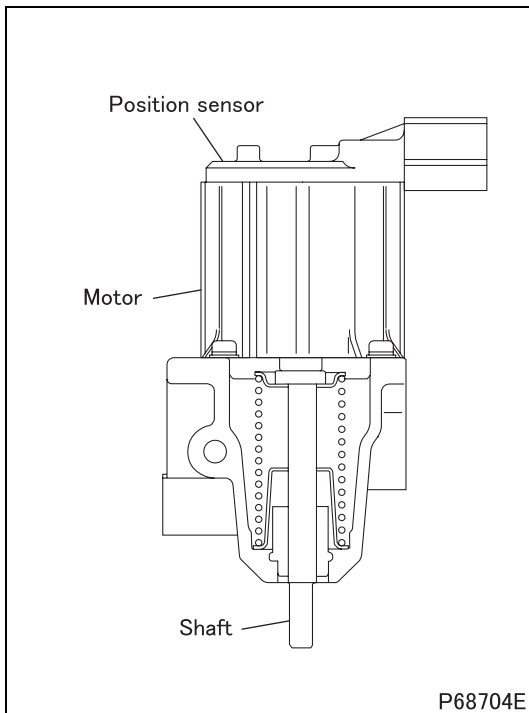

### (2.1) Turbocharger actuator

- In response to command signals from the turbocharger electronic drive unit, the turbocharger actuator moves the shaft up and down by means of its DC motor to open and close the turbine vanes.

## (3) Fault diagnosis function

- The engine electronic control unit continuously monitors the electronic drive units and sensors for faults. In the event that the engine electronic control unit finds a component faulty, it causes an indication to be made in the meter cluster to alert the driver. At the same time, it memorizes the fault location in the form of a diagnosis code and starts a control during fault.
- While the engine is running, the turbocharger electronic drive unit continuously monitor communication with the position sensor and motor of the turbocharger actuator communication with the engine electronic control unit. In the event that they identify a fault, they send fault data to the engine electronic control unit.
- While control necessitated by a fault is taking place, the system's functionality is limited to ensure vehicle and driver safety. It is possible to read the memorized diagnosis code using a Multi-Use Tester or from flashing of the warning lamp.
- The control during fault recovers by servicing the faults. However, for some diagnosis codes, the warning lamp stays illuminated until the normal signals are input for several times.
- Diagnosis codes shown by the Multi-Use Tester and those indicated by flashing of the warning lamp are different.
- The Multi-Use Tester is capable of showing more detailed diagnosis codes.

### 3.3 Electronic control unit wiring diagram

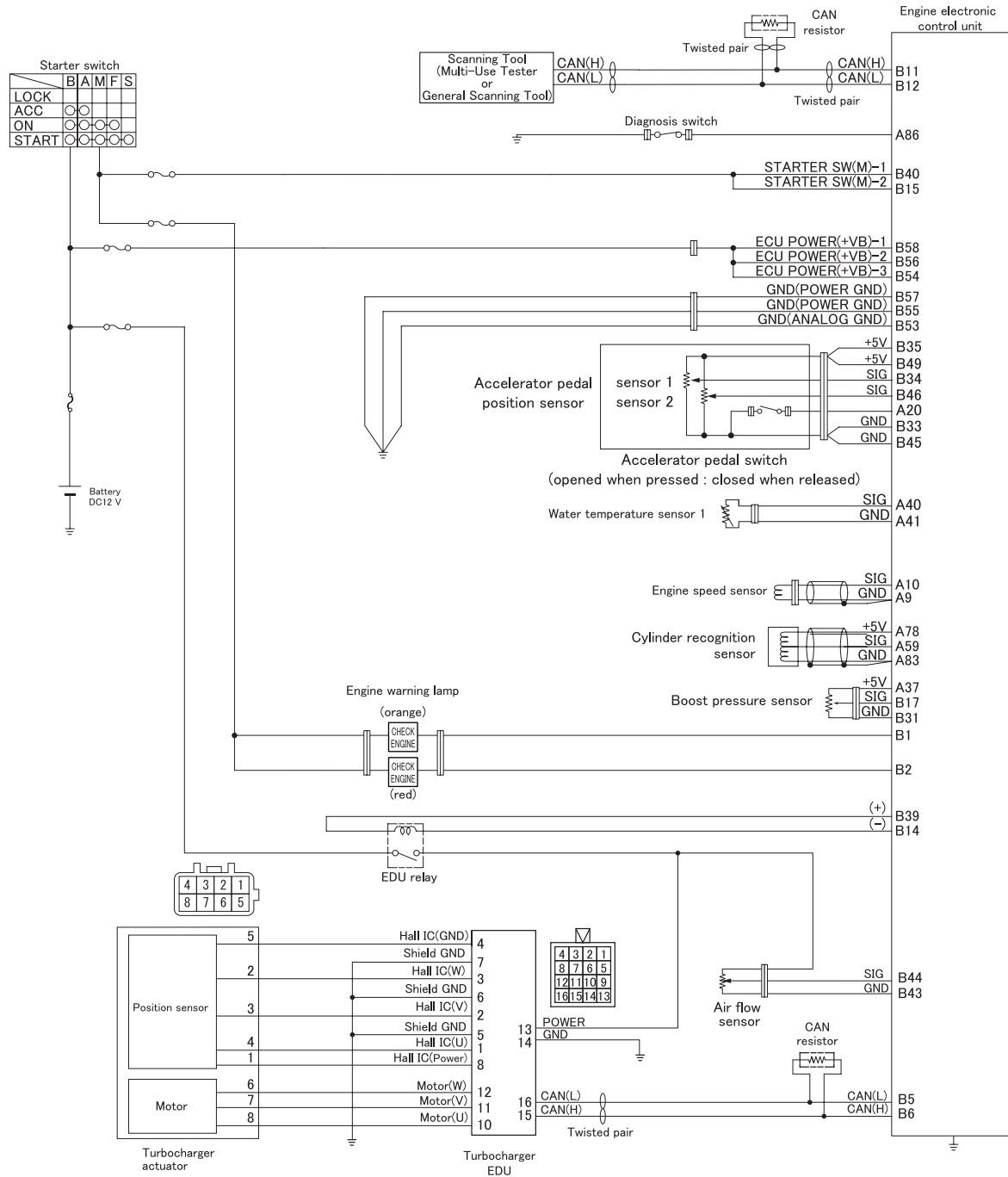

CAN : Controller area network  
EDU : Electronic drive unit

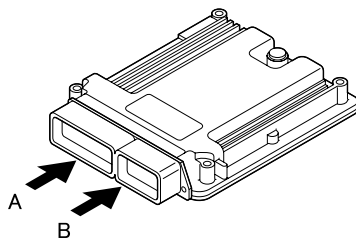

A: GE96A

24	23	22	21	20	19	18	17	16	15	14	13	12	11	10	9	8	7	6	5	4	3	2	1
48	47	46	45	44	43	42	41	40	39	38	37	36	35	34	33	32	31	30	29	28	27	26	25
72	71	70	69	68	67	66	65	64	63	62	61	60	59	58	57	56	55	54	53	52	51	50	49
96	95	94	93	92	91	90	89	88	87	86	85	84	83	82	81	80	79	78	77	76	75	74	73

B: GE58A

54	53	13	12	11	10	9	8	7	6	5	4	3	2	1
56	55	26	25	24	23	22	21	20	19	18	17	16	15	14
		39	38	37	36	35	34	33	32	31	30	29	28	27
58	57	52	51	50	49	48	47	46	45	44	43	42	41	40

See Gr13EA for control concerning engine electronic control unit.

# STRUCTURE AND OPERATION

---

## 4. Diesel Particulate Filter Regeneration Control System

### 4.1 General

- The diesel particulate filter regeneration control system burns and removes the particulate matter (PM) in the ceramic filter using high temperature exhaust gas to prevent excessive accumulation of particulate matter in the ceramic filter. Thus the diesel particulate filter is regenerated.
- The regeneration is divided into two types. One is the continuous regeneration utilizing high temperature exhaust gas during high-speed or high-load operations. The other is the automatic or **parked** regeneration which uses high temperature exhaust gas created by the regeneration control by the engine electronic control unit.
- For automatic or **parked** regeneration, the engine electronic control unit estimates the accumulated amount of particulate matter from the vehicle operating hours, driving distance and the engine condition during driving, and the regeneration is performed by controlling the fuel injection (amount and timing), turbocharger, exhaust shutter and intake throttle to make high temperature exhaust gas.



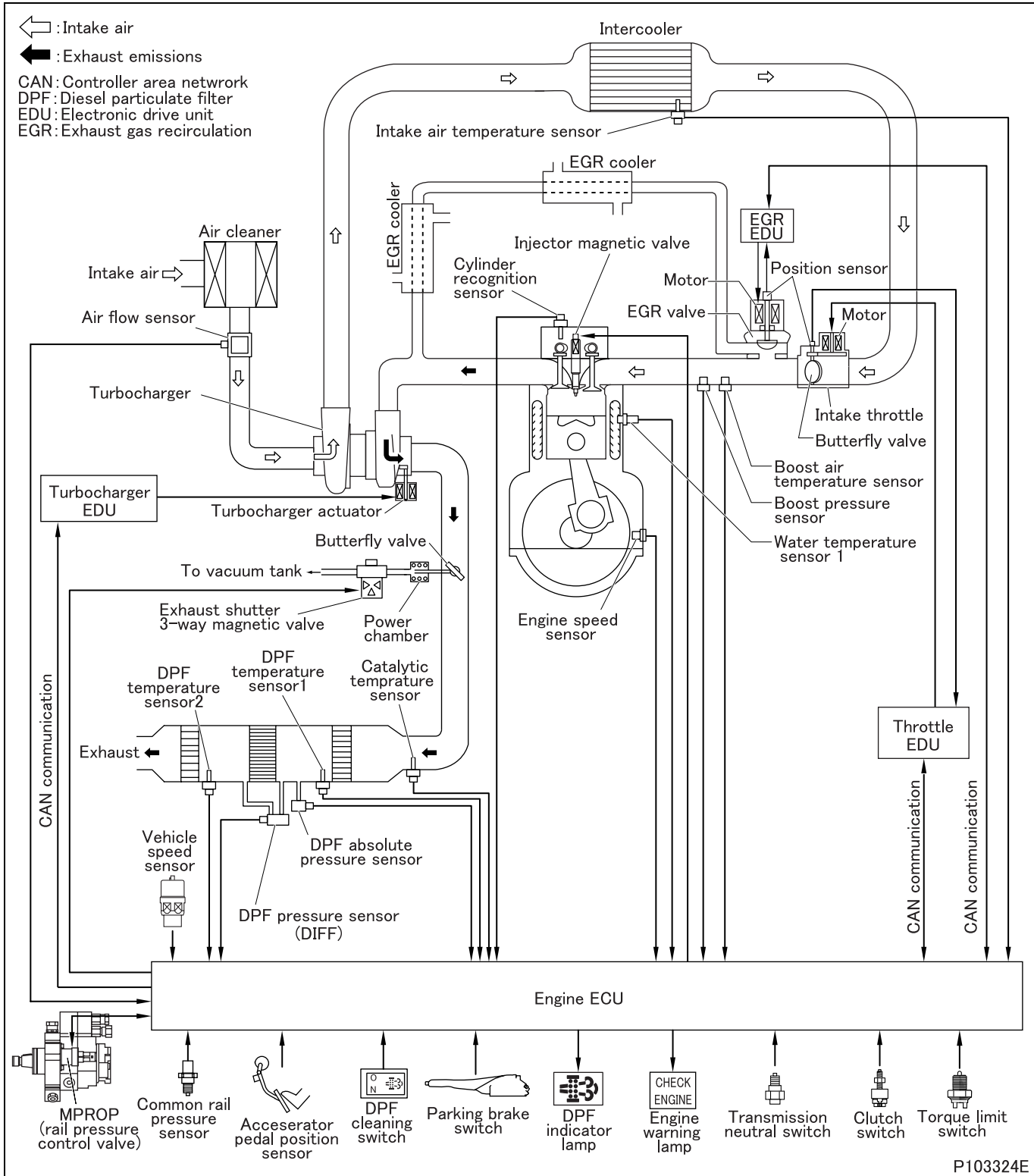

# STRUCTURE AND OPERATION

## 4.2 Continuous regeneration and regeneration control

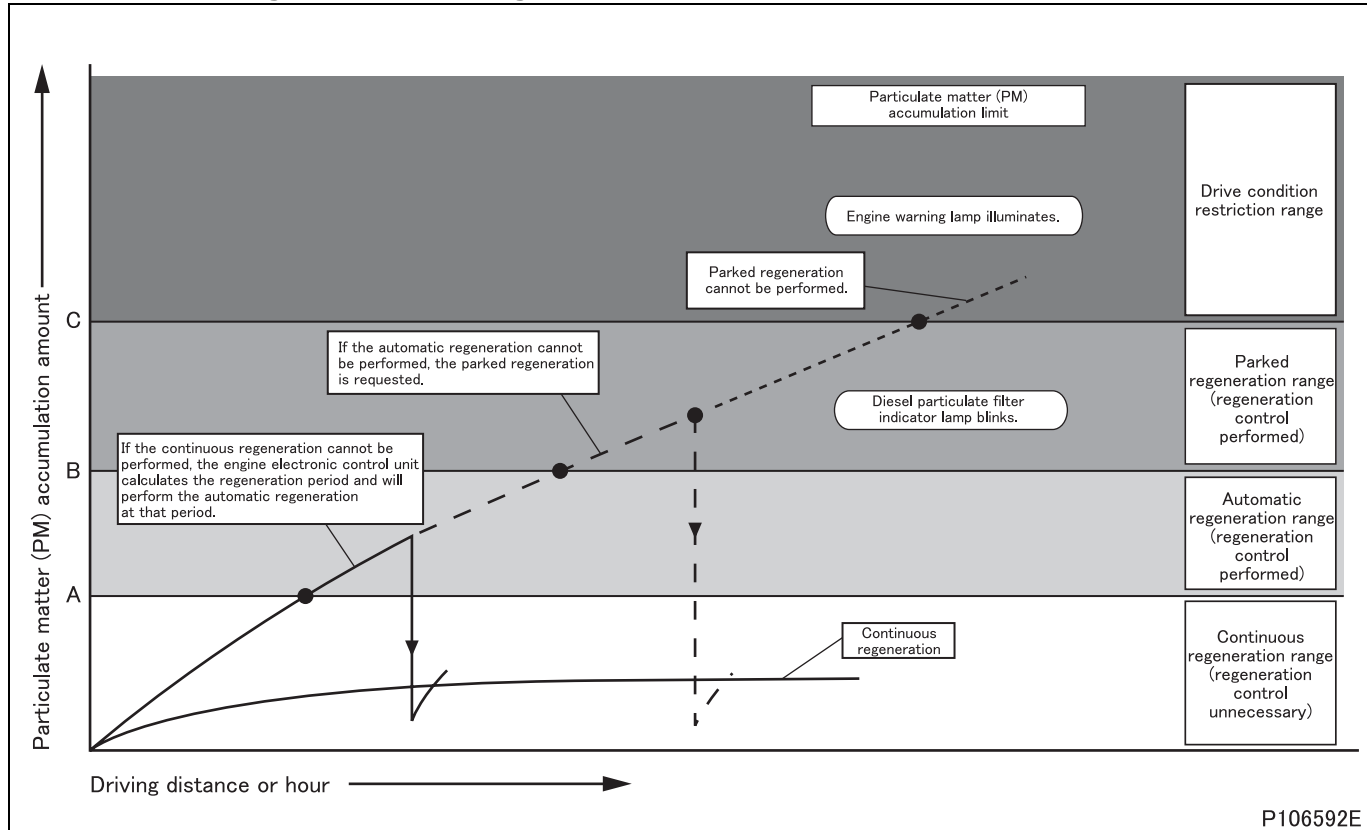

- The above diagram shows the relations between the driving distance or hours and the particulate matter accumulation amount, and the range of each diesel particulate filter regeneration operation.
- The particulate matter accumulation amount increases as the driving distance or hours increase. However, by conducting the regeneration operation that matches the vehicle operating condition and the particulate matter accumulation amount, the particulate matter accumulation amount is reduced to keep the performance of the diesel particulate filter.
- The regeneration is divided into two types – the continuous regeneration utilizing exhaust gas during normal driving operation and the automatic or **parked** regeneration which uses exhaust gas created by the regeneration control.

### (1) Continuous regeneration

- When exhaust gas temperature is high during high-speed or high-load operation,  $\text{NO}_2$  created by the action of the front oxidation catalyst continuously burns the particulate matter accumulated in the ceramic filter.

### (2) Regeneration control

#### (2.1) Automatic regeneration

- When the particulate matter accumulation level is between A and B on the diagram, the engine electronic control unit decides the regeneration period and the automatic regeneration will be performed at an appropriate period. During regeneration, the unburnt fuel (HC) supplied by the post injection is oxidized by the front oxidation catalyst, and the oxidation heat from that reaction burns the particulate matter accumulated in the ceramic filter.

## (2.2) Parked regeneration

- When the particulate matter accumulation level is between B and C on the diagram, the engine electronic control unit makes the diesel particulate filter indicator lamp blink. If the diesel particulate filter cleaning switch is turned on by the driver when the following conditions are met, the parked regeneration will take place.
  - Engine has warmed up (coolant temperature: 70°C {158°F} or higher)
  - Diesel particulate filter cleaning switch: ON (Press the switch until the diesel particulate filter indicator stays on.)
  - Accelerator pedal released (accelerator pedal position sensor: 0%)
  - Parking brake applied (parking brake switch: ON)
  - Transmission in neutral position (transmission neutral switch: OFF)
  - Clutch pedal released (clutch pedal switch: ON)
  - Power take-off inactive (power take-off switch: OFF)
- During regeneration, the diesel particulate filter indicator lamp blinks in two intervals (slow and fast) in accordance with the particulate matter accumulation amount.
- The exhaust gas temperature increase procedure and the particulate matter burning procedure are the same as that for the automatic regeneration.

## (2.3) Restriction on drive conditions

- When the particulate matter accumulation level exceeds C on the diagram, the engine warning lamp illuminates and some restrictions are applied to the driving conditions.

## 4.3 Diesel particulate filter unit

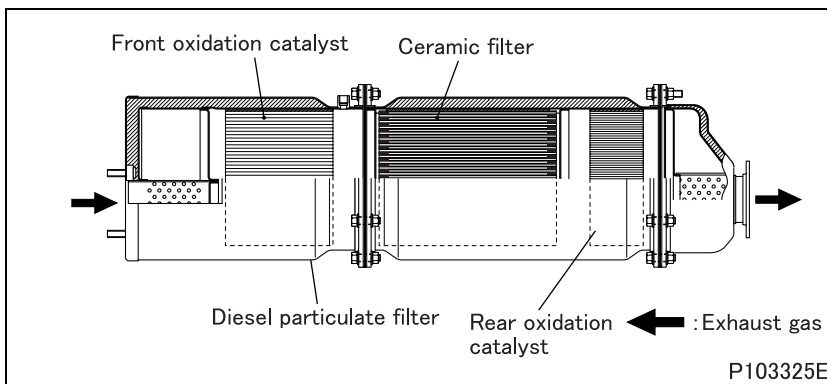

- Diesel particulate filter unit consists of the front oxidation catalyst, ceramic filter and rear oxidation catalyst.

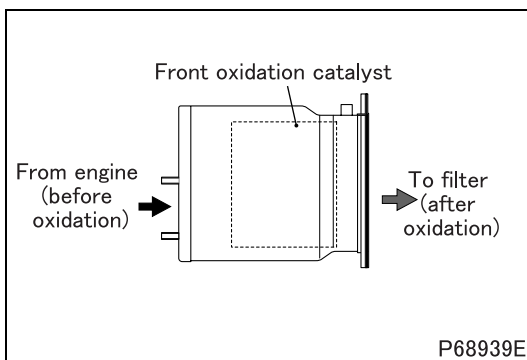

### (1) Front oxidation catalyst

- In normal driving condition, unburnt fuel (HC) and part of the particulate matter in the exhaust gas from the engine is purified by this catalyst.
- During filter regeneration, the unburnt fuel (HC) supplied by the post injection is oxidized by the front oxidation catalyst, and the oxidation heat raises exhaust gas temperature.

# STRUCTURE AND OPERATION

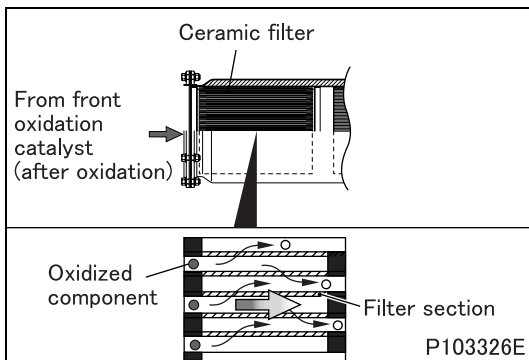

## (2) Ceramic filter

- The ceramic filter is an aggregate of thin tubes, and these tubes are closed at either end alternatively. During normal operation, particulate matter is trapped when the exhaust gas enters a tube and passes through the wall of the tube (filter section) to the adjacent tube.
- During regeneration, the particulate matter accumulated in the filter is cleared by burning at high temperature. This, however, cannot remove the calcium (ash) contained in the engine oil and the ash will accumulate in the filter. The excessively accumulated ash may cause early clogging of the ceramic filter. Therefore, the ceramic filter must be cleaned periodically.

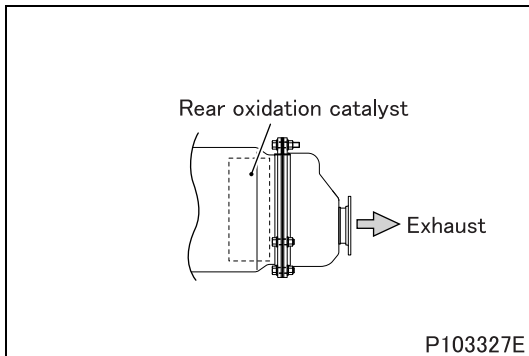

## (3) Rear oxidation catalyst

- The rear oxidation catalyst oxidize and remove the components (HC and CO) which remain untreated through the diesel particulate filter.

### 4.4 Electronic control system

#### (1) System block diagram

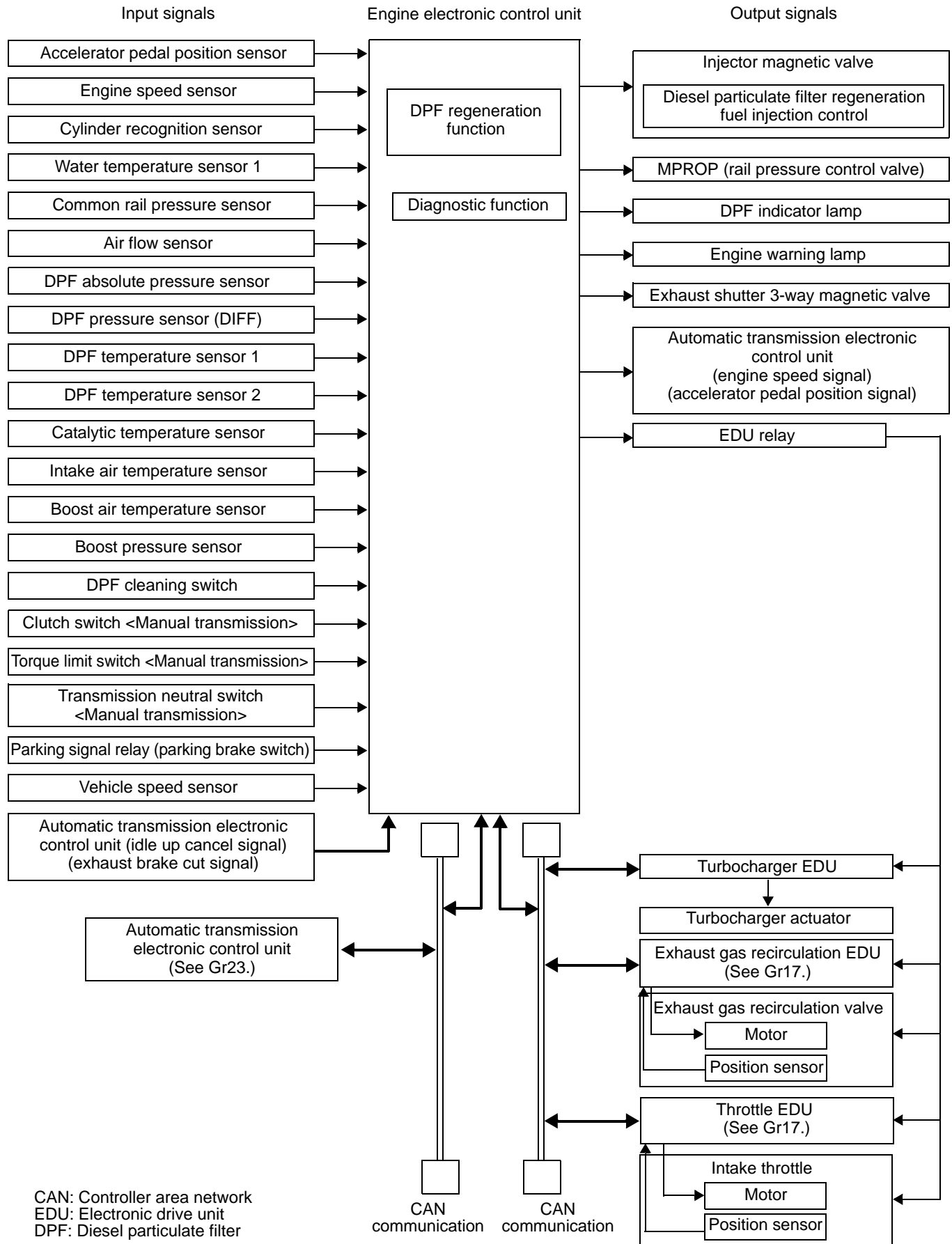

# STRUCTURE AND OPERATION

Part	Main function/operation
Accelerator pedal position sensor	Detection of extent of accelerator pedal depression
Engine speed sensor	Detection of engine speed
Cylinder recognition sensor	Cylinder recognition
Water temperature sensor 1	Detection of coolant temperature
Common rail pressure sensor	Sensing of common rail pressure
Air flow sensor	Detection of intake air flow rate
DPF absolute pressure sensor	Detection of DPF absolute pressure
DPF pressure sensor (DIFF)	Detection of DPF differential pressure
DPF temperature sensor 1	Detection of ceramic filter inlet temperature
DPF temperature sensor 2	Detection of ceramic filter outlet temperature
Catalytic temperature sensor	Detection of front catalyst inlet temperature
Intake air temperature sensor	Detection of upper stream side intake air temperature (in the intercooler)
Boost air temperature sensor	Detection of downstream side intake air temperature (after joining the exhaust gas recirculation)
Boost pressure sensor	Sensing of boost pressure
DPF cleaning switch	ON/OFF changeover of DPF <b>parked</b> regeneration
Clutch switch <Manual transmission>	Detection of released/pressed condition of clutch pedal (OFF with pedal released)
Torque limit switch <Manual transmission>	Detection of 1st and reverse positions
Transmission neutral switch <Manual transmission>	Detection of transmission neutral condition (OFF with transmission in neutral)
Parking signal relay (parking brake switch)	Detection of parking condition (turns ON when the parking brake is applied)
Injector magnetic valve	DPF regeneration fuel injection control
MPROP (rail pressure control valve)	Control of fuel injection pressure
DPF indicator lamp	Illuminates when the particulate matter accumulation in the DPF exceeds a certain value.
Engine warning lamp	Indication of system abnormalities Illuminates when the particulate matter accumulation in the DPF is excessive.
Exhaust shutter 3-way magnetic valve	ON/OFF changeover of exhaust shutter
Automatic transmission electronic control unit (engine speed data for automatic transmission control)	Output of engine speed for automatic transmission control
Automatic transmission electronic control unit (accelerator pedal position for automatic transmission control)	Output of extent of accelerator pedal depression for automatic transmission control
EDU relay	Switching ON/OFF supply of power to EGR EDU, turbocharger EDU and throttle EDU
Automatic transmission electronic control unit (idle up cancel signal and exhaust brake cut signal)	<ul style="list-style-type: none"> <li>Releasing the idle-up other than N range</li> <li>Prohibition of the activation of auxiliary brake when the vehicle speed is 10 km/h or lower</li> </ul>
Controller area network communication (automatic transmission electronic control unit)	<ul style="list-style-type: none"> <li>Engine data recognized by the engine electronic control unit are outputted to the controller area network bus to enable systems to obtain data that they need for control.</li> <li>Each automatic transmission electronic control unit issues signals to the engine electronic control unit to enable it to effect engine control appropriate for each type of system control. (See Gr23 for control of automatic transmission electronic control unit)</li> </ul>
Controller area network communication (turbocharger EDU, throttle EDU and EGR EDU)	<ul style="list-style-type: none"> <li>Engine data recognized by the engine electronic control unit are outputted to the controller area network bus to enable systems to obtain data that they need for control.</li> <li>Each EDU opens/closes the valves to increase exhaust gas temperature for DPF regeneration. (See Gr17 for control of throttle EDU and EGR EDU)</li> </ul>

**(2) Fault diagnosis function**

- The engine electronic control unit continuously monitors the electronic drive units and sensors for faults. In the event that the engine electronic control unit finds a component faulty, it causes an indication to be made in the meter cluster to alert the driver. At the same time, it memorizes the fault location in the form of a diagnosis code and starts a control during fault.
- While control necessitated by a fault is taking place, the system's functionality is limited to ensure vehicle and driver safety. It is possible to read the memorized diagnosis code using a Multi-Use Tester or from flashing of the warning lamp.
- Diagnosis codes shown by the Multi-Use Tester and those indicated by flashing of the warning lamp are different.
- The Multi-Use Tester is capable of showing more detailed diagnosis codes.

# STRUCTURE AND OPERATION

## 4.5 Electronic control unit wiring diagram

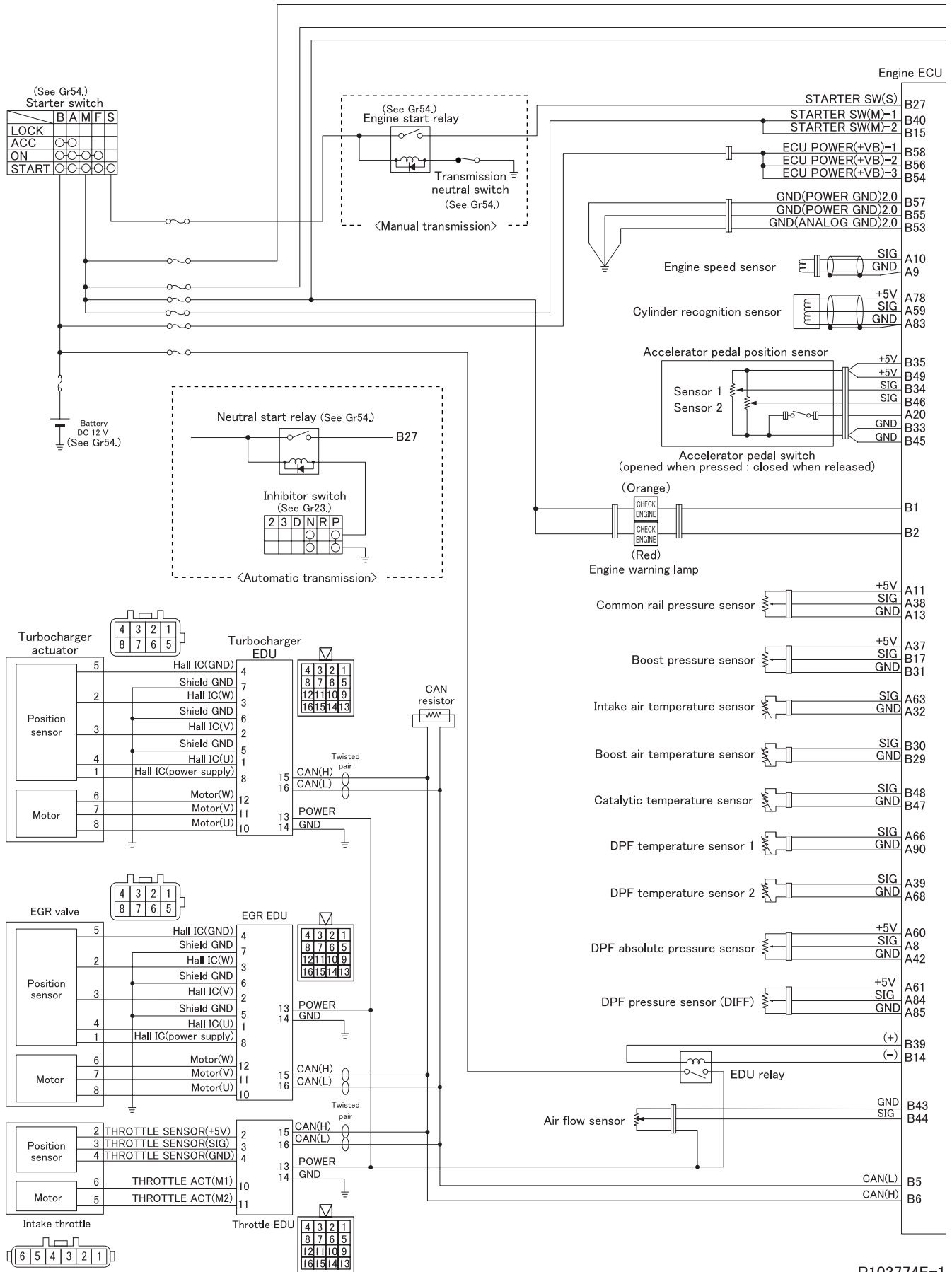

P103774E-1



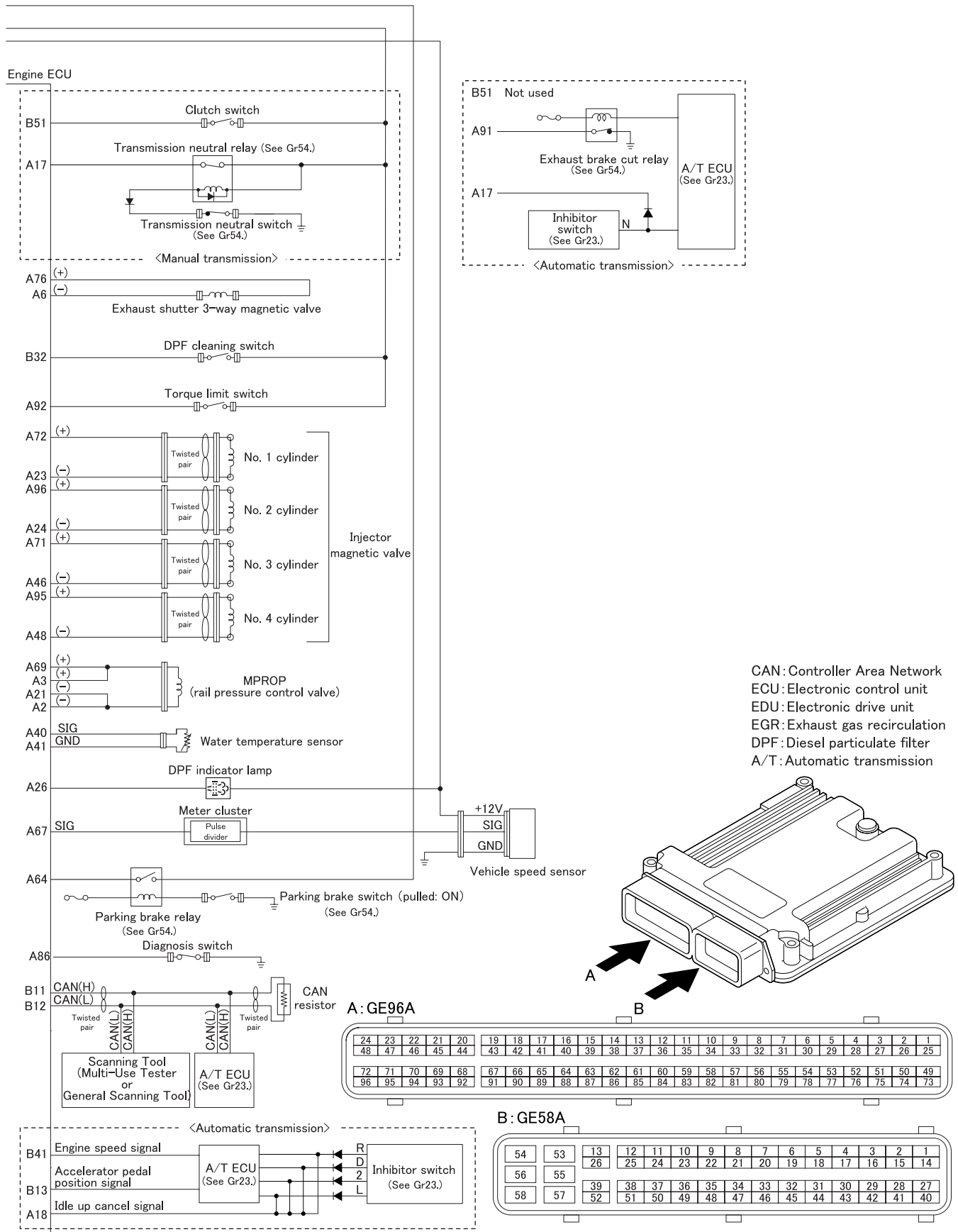

See Gr13EA for control concerning engine electronic control unit.

P103774E-2

# TROUBLESHOOTING

Possible causes		Symptoms						Reference Gr
			Engine is difficult to start	Exhaust gas is black	Exhaust gas is white	Engine output is insufficient	Fuel consumption is too high	
Air cleaner	Clogged air cleaner element		○	○		○		
Turbocharger	Cartridge assembly	Defective bearing		○		○		○
		Carbon deposits on turbine wheel		○		○		
		Interference between turbine wheel and turbine back plate			○		○	
		Interference between turbine wheel and turbine housing			○		○	
		Bent shaft		○		○		○
		Damaged turbine wheel		○		○		○
		Interference between compressor wheel and compressor cover			○		○	
		Seizure of thrust sleeve and/or thrust bearing			○		○	
		Damaged compressor wheel			○		○	
		Oil leakage due to worn piston ring and/or insert			○	○		○
		Poorly installed piston ring						○
		Unsmooth sliding of inner parts due to clogged lubricating oil pipe and/or eyebolt			○		○	
		Damaged oil seals due to clogged oil return pipe				○		○
		Poorly mounted compressor cover			○		○	○
Poorly mounted turbine housing					○	○		
Intercooler					○			
Throttle actuator	Butterfly valve stuck in closed position			○	○	○		Gr13E
	Poorly adjusted butterfly valve			○	○	○		
Deformed front pipe, muffler, and/or tail pipe							○	
Poorly installed front pipe, muffler, and/or tail pipe							○	
Inappropriate valve clearance				○				Gr11
Defective cylinder head gasket				○				
Worn valve and valve seat and/or carbon deposits				○				
Weakened valve springs				○				
Worn and/or damaged piston rings					○		○	
Worn and/or damaged piston ring grooves					○		○	
Malfunctioning cooling system				○				Gr14
Excessive engine oil level					○			Gr12
Seizure of main moving parts				○				Gr11
Uneven or excessive fuel injection				○				Gr13E

## 1. Measurement of Turbocharger Boost Pressure

### Service standards

Location	Maintenance item	Standard value	Limit	Remedy
-	Boost pressure	126 to 164 kPa {37.2 to 48.4 in.Hg, 945 to 1230 mmHg}	-	Replace

### 1.1 Preparation

- Place the transmission in neutral. (in the parking range P for automatic transmissions.)
- Hold the steering wheel in neutral position.
- Turn off lamps and accessory devices not to increase the engine speed.
- Connect the Multi-Use Tester. (See Gr00.)
- If any fault exists (corresponding diagnosis code is issued), rectify it.
- Warm up the engine until the engine coolant has been heated to more than 60°C {140°F}. (Determine coolant temperature from service data [32: Water temperature].)
- Check that the non-load minimum speed (idling speed) is as specified. (See Gr13A.)

### 1.2 Measurement and correction of boost pressure

- Set the diagnosis switch to OFF (disconnect the fuse). (See Gr00.)
- Select [A4: VGT1] in [Actuator Test] of the Multi-Use Tester. Set [Target Value] to 80% and execute.
- When [A4: VGT1] is executed, the engine speed should be automatically increased to 2500 rpm.
- Maintain the state of [Target Value] having been executed (for 5 to 15 minutes) until boost pressure is stabilized.
- Measure the following items from among [Service Data].  
20: Atmospheric pressure (measured atmospheric pressure)  
21: Boost pressure (measured boost pressure)  
30: Intake Air Temp. (upper stream) (measured air temperature)  
After the measurements, set the diagnosis switch to ON (connect the fuse).
- Obtain boost pressure correction value respectively by calculating above Service Data.

#### [Calculation of atmospheric pressure correction value]

Atmospheric temperature correction value = Measured atmospheric temperature - 100

#### [Calculation of boost pressure correction value]

- Obtain the boost pressure correction value using the following equation.  
Boost pressure correction value = Measured boost pressure - atmospheric temperature correction value
- If boost pressure correction value deviates from the standard value, replace the turbocharger.

# AIR DUCT AND AIR CLEANER

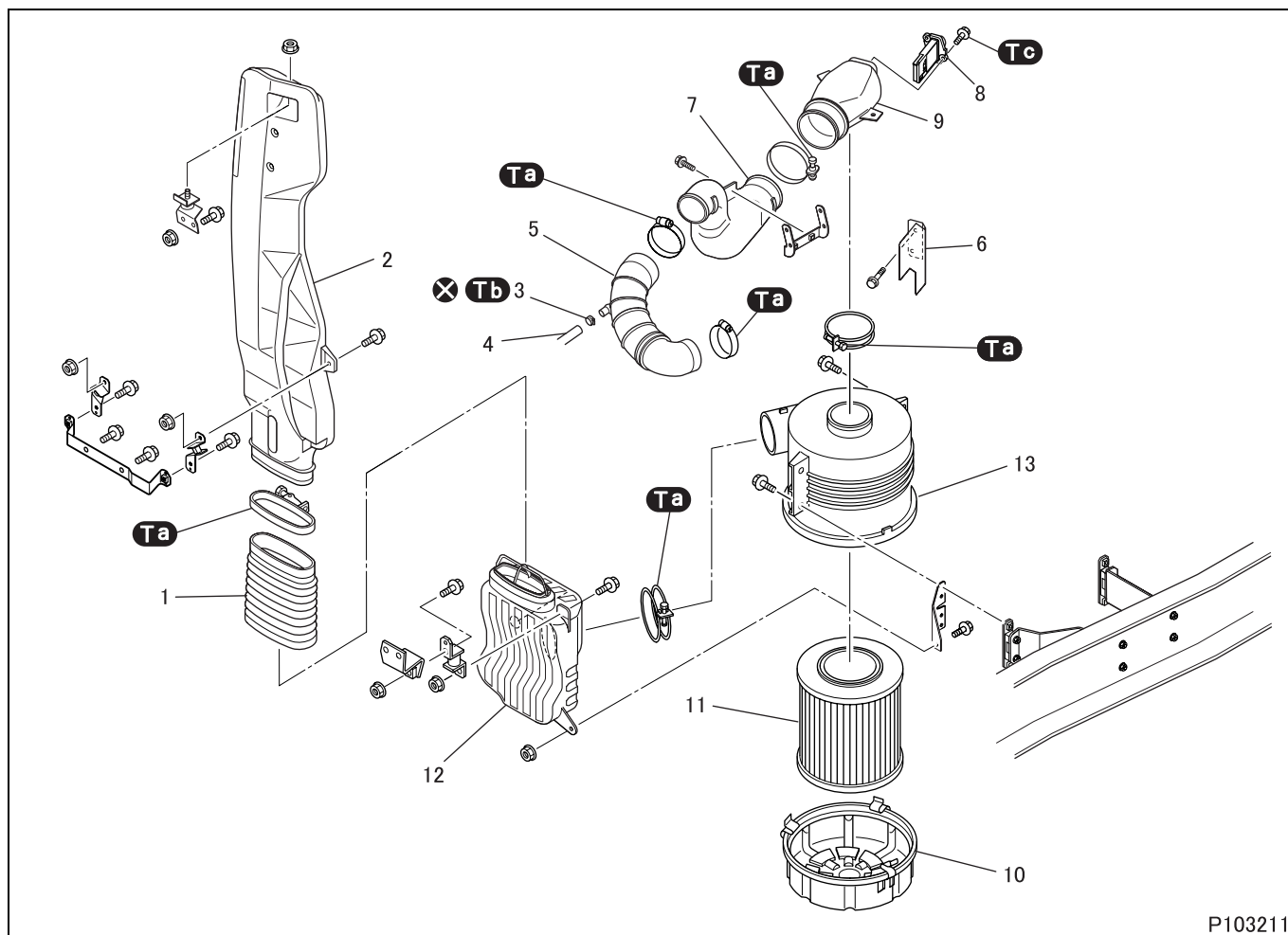

## ● Disassembly sequence

- |                  |                        |
|------------------|------------------------|
| 1 Connector      | 7 Air duct             |
| 2 Air inlet duct | 8 Air flow sensor      |
| 3 Clamp          | 9 Connector            |
| 4 PCV hose       | 10 Air cleaner cap     |
| 5 Air hose       | 11 Air cleaner element |
| 6 Insulator      | 12 Air box             |

13 Air cleaner case

⊗: Non-reusable parts

PCV: Positive Crankcase Ventilation



## ● Assembly sequence

Follow the disassembly sequence in reverse.

## Tightening torque (Unit: N·m {ft.lbs, kgf·m})

Mark	Parts to be tightened	Tightening torque	Remarks
Ta	Clamp	3.0 to 3.4 {2.2 to 2.5, 0.3 to 0.35}	—
Tb	Clamp	9.0 to 11 {6.6 to 8.1, 0.9 to 1.1}	—
Tc	Bolt (air flow sensor mounting)	1.2 to 1.8 {0.9 to 1.3, 0.1 to 0.2}	—

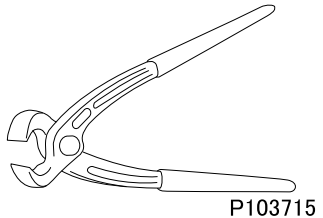
## Special tools

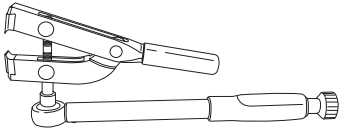
Mark	Tool name and shape	Part No.	Application
	Pincer 	MH063865	Removal of hose clamp
	Clamp installation tool 	MH063866	Installation of hose clamp

### ◆ Removal procedure ◆

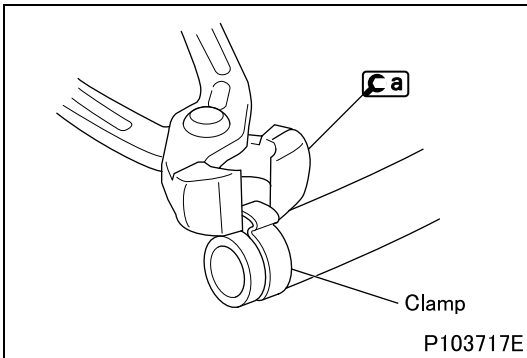

#### ■ Removal: Clamp

- To remove the clamp, cut the clamp using .

### ◆ Cleaning procedure ◆

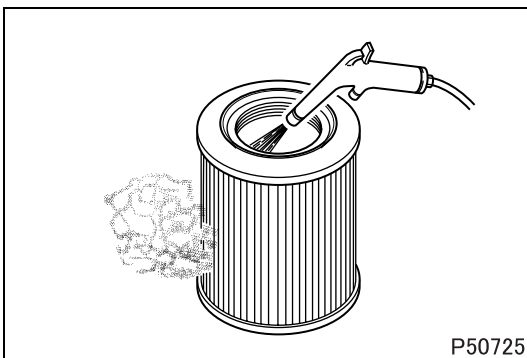

#### ■ Cleaning: Filter element

- Blow a jet of compressed air at a pressure not higher than 685 kPa {100 psi, 7 kgf/cm<sup>2</sup>} against the inside surfaces of the element.
- Move the compressed air jet up and down along all pleats of the filter paper element.

#### CAUTION

- Do not strike the element or hit it against another object to remove dust.
- Do not blow compressed air against outside surfaces of the element.

# AIR DUCT AND AIR CLEANER

## ◆ Inspection procedure ◆

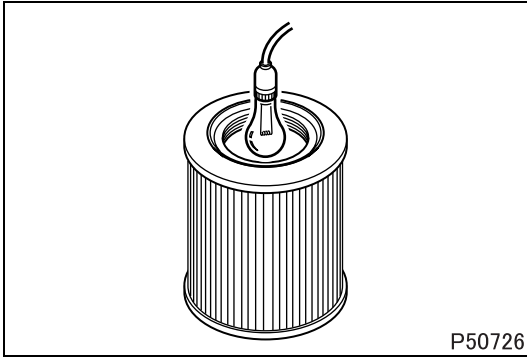

### ■ Inspection: Element

- Shine some electric light inside the element.
- Replace the element if thin spots or broken parts are evident in the filter paper, or if the packing at the top of the element is damaged.

Also replace the element if the dust on the element is damp with oily smoke or soot, regardless of the replacement schedule.

## ◆ Installation procedure ◆

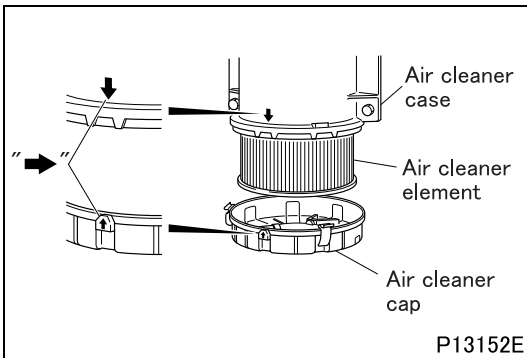

### ■ Installation: Air cleaner cap

➔ : Alignment mark

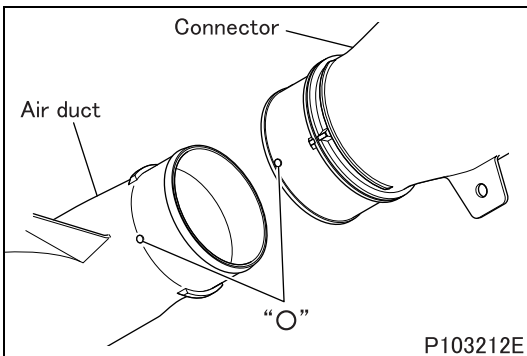

### ■ Installation: Air duct

- Align the marks "○" on air duct and push it in until it hits stopper.

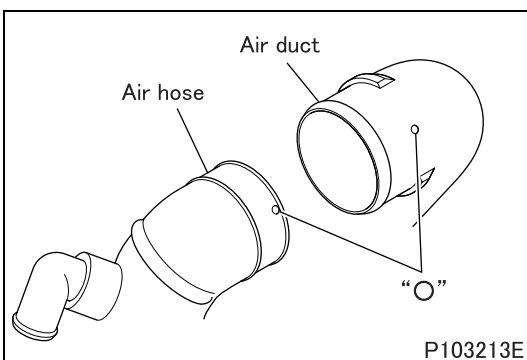

### ■ Installation: Air hose

- Align the marks "○" on air hose and push it in until it hits stopper.

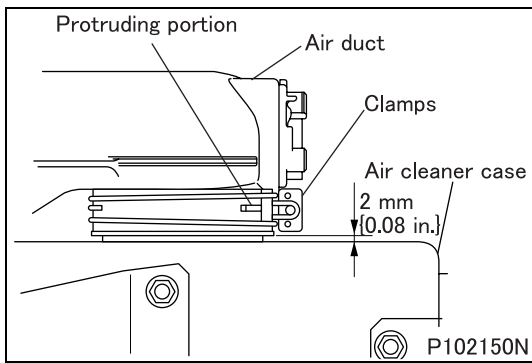
**■ Installation: Air duct**

- The protruding portion of the connector is put between clamps.
- Installation is such that the space between the connector and the air cleaner case measures the amount shown in the figure.

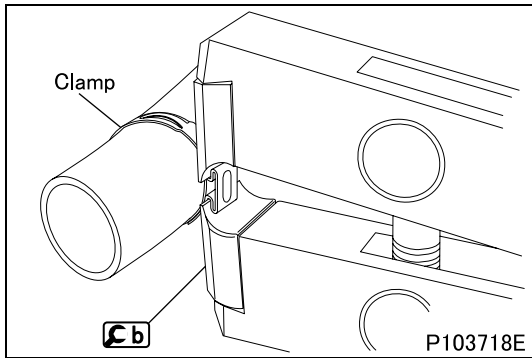
**■ Installation: Clamp**

- Pinch the projecting part of the clamp with **Ⓒb** and tighten to the specified torque.

# DIESEL PARTICULATE FILTER INSPECTION

## 2. Diesel Particulate Filter Unit Inspection for Clogging and Cleaning the Diesel Particulate Filter Unit







### CAUTION

- Diesel particulate filter has become very hot after the operation of engine. Cool down the diesel particulate filter sufficiently so as not to get burnt.
- The ceramic filter must be cleaned at first 176,000 km {110,000 miles} of driving, and then every 104,000 km {65,000 miles} of driving. Otherwise, ash will accumulate in the filter and the filter may be damaged.

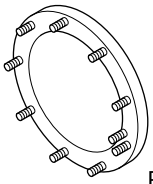
### Service standards

Location	Maintenance item	Standard value	Limit	Remedy
-	Diesel particulate filter differential pressure (after re-generation and cleaning, at no-load max. speed)	Less than 15 kPa {2.2 psi, 0.2 kgf/cm <sup>2</sup> }	15 kPa or more {2.2 psi, 0.2 kgf/cm <sup>2</sup> }	Replace

### Special tools

Mark	Tool name and shape	Part No.	Application
 a	Adapter  P103810	MH063867	Washing of ceramic filter
 b	Flange nut (M10)	MF434105	
 c	Drain plug (M12 × 1.25)	MF665003	
 d	Drain plug (M14 × 1.5)	MF665004	
 e	Gasket (M12)	MF665004	
 f	Gasket (M14)	MF660065	

### 2.1 Preparation

- Place the transmission to neutral position.
- Turn the steering wheel in neutral position. Apply the parking brake securely.
- Turn off the air conditioner not to increase the engine speed.
- Connect the Multi-Use Tester. (See Gr00.)
- Check if there is any diagnosis code stored in the memories of the electronic control units. Repair if any fault is found.
- Warm up the engine until the coolant temperature becomes 70°C {158°F}. (Check this by Multi-Use Tester service data “35: coolant temperature”.)
- Perform resetting of electronic control unit “History reset” using Multi-Use Tester. (See later section.)



## 2.2 Inspection procedure

- Perform the inspection in accordance with the following flowchart.

### CAUTION

- The differential pressure of diesel particulate filter, that is, the pressure difference between the inlet and outlet of the diesel particulate filter, may exceed 30 kPa {4.4 psi, 0.3 kgf/cm<sup>2</sup>} due to the clogging of the ceramic filter. If the diesel particulate filter regeneration is performed using Multi-Use Tester actuator test “DPF regeneration (park)”, the abnormal combustion of the particulate matter may make the diesel particulate filter excessively high temperature, resulting in damage of the diesel particulate filter. Before performing the diesel particulate filter regeneration, therefore, be sure to check that the diesel particulate filter differential pressure is less than 30 kPa {4.4 psi, 0.3 kgf/cm<sup>2</sup>}.
- When replacing the electronic control unit to a new one, current ash accumulation data must be copied to the new electronic control unit.
- For data copying procedure, consult your nearest **STERLING TRUCKS** dealer or **STERLING TRUCKS CORPORATION**.

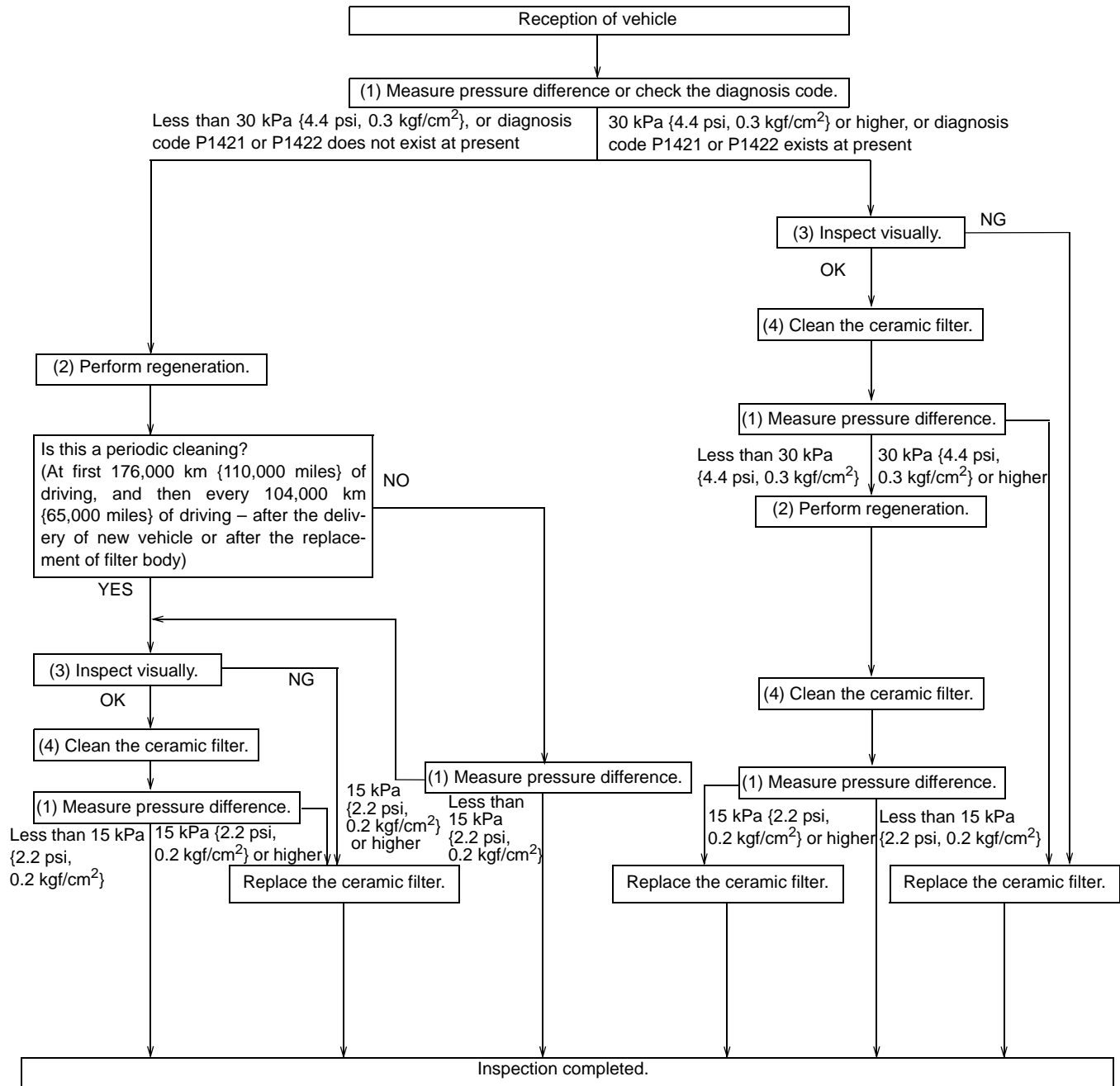

# DIESEL PARTICULATE FILTER INSPECTION

## (1) Measurement of pressure difference

- Measure the pressure difference with the accelerator pedal fully pressed.
- Measurement can be performed using Multi-Use Tester service data "32: DPF pressure difference".

## (2) Regeneration

- Perform Multi-Use Tester actuator test "A5: DPF regeneration (parked)".

## CAUTION



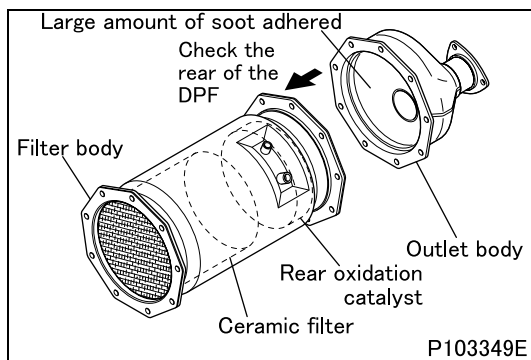



- **The exhaust gas during regeneration is extremely hot. Be sure to confirm that there is no flammables around the rear of the vehicle.**



## (3) Visual inspection

- Disassemble the diesel particulate filter and check the following.
  - Check if a large amount of soot adheres inside the diesel particulate filter outlet body.
  - Check the rear oxidation catalyst after the ceramic filter for damage.
- If a large amount of soot adheres inside the outlet body or if a damage is found on the rear oxidation catalyst, engine-related fault may be suspected. Replace the diesel particulate filter.

## (4) Cleaning

- Fit  **a** to the filter body with  **b** and tighten  **b** to the specified torque (43 N·m {32 ft.lbs, 4.4 kgf·m}).  
Fit  **c** and  **e** to the sensor mounting hole on the filter body and tighten them to the specified torque (30 N·m {22 ft.lbs, 3.1 kgf·m}).  
Fit  **d** and  **f** to the sensor mounting hole on the filter body and tighten them to the specified torque (40 N·m {30 ft.lbs, 4.1 kgf·m}).

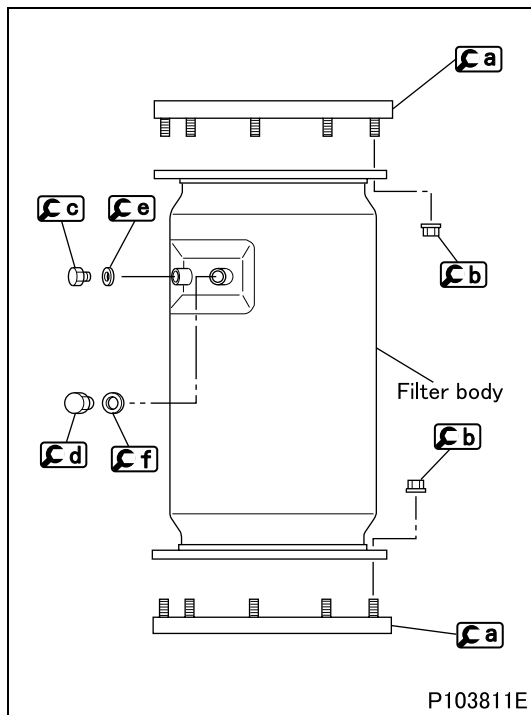

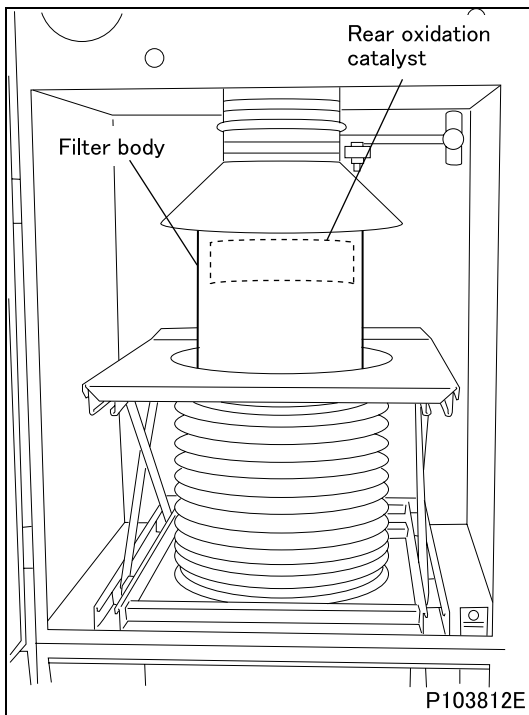

- Set the filter body in the cleaning machine with its rear oxidation catalyst side upward.
- Be sure to fit the cleaning machine and the filter body with no air leaks between them.
- Set the air pressure to 620 kPa {90 psi, 6.3 kg/cm<sup>2</sup>}.
- Set the timer to 10 to 15 minutes (25 pulses/once) and perform cleaning.
- For the handling procedure of the cleaning machine, refer to its instruction manual.

### 3. Resetting the DPF-related Information (Resetting Electronic Control Unit)

- On the regeneration control type as diesel particulate filter system, the engine electronic control unit stores many DPF-related information to control the diesel particulate filter regeneration as diesel particulate filter history.
- This history is automatically reset by the engine electronic control unit when the diesel particulate filter regeneration is performed.
- If the ceramic filter is replaced or cleaned without regeneration, reset the DPF history using Multi-Use Tester as follows.

#### 3.1 Preparation

- This operation should be performed under the following conditions.
  - Starter switch: ON (but do not start the engine)
  - Vehicle parked
  - Diagnosis switch: ON (fuse installed)
  - Transmission: Neutral (or P position for automatic transmission)

#### 3.2 Resetting procedure

##### (1) Error while operating the Multi-Use Tester

###### [Communication error] screen

- This screen will appear when a reject response signal is sent from the engine electronic control unit to the Multi-Use Tester while performing any operation.
- In this case, check if the conditions for the execution of the procedure are satisfied and retry from the beginning.
- Click "OK".

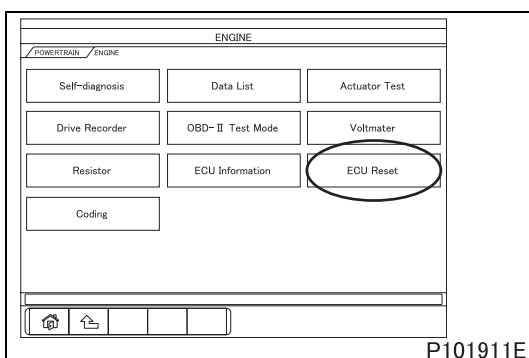
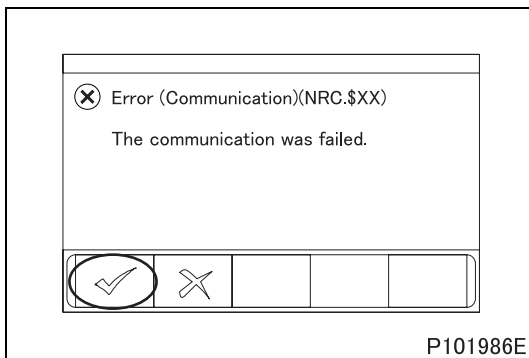

##### (2) System selection

- From the System selection menu, select "Engine/Transmission". The engine control-related menu will appear.
- Select "ECU Reset".

# DIESEL PARTICULATE FILTER INSPECTION

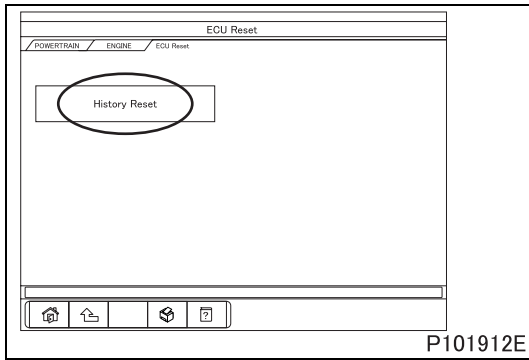

### (3) ECU reset function selection

#### [ECU reset] screen

- Select "History Reset".

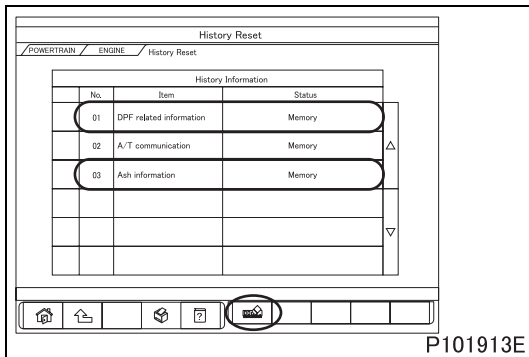

### (4) History reset

#### [History reset] screen

- Depending on the action performed on the ceramic filter, the contents of resetting differ.
  - Filter replacement: 01 "DPF-related information"
  - Filter cleaning: 03 "Ash information"
- Click "Reset" button.
  - If the status column shows "No memory stored", no resetting action required. Finish this procedure.

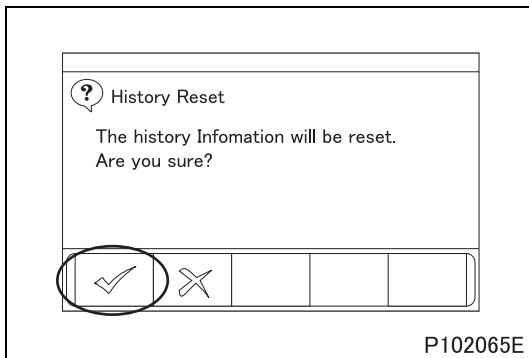

#### [History reset confirmation] screen

- Click "OK" button.

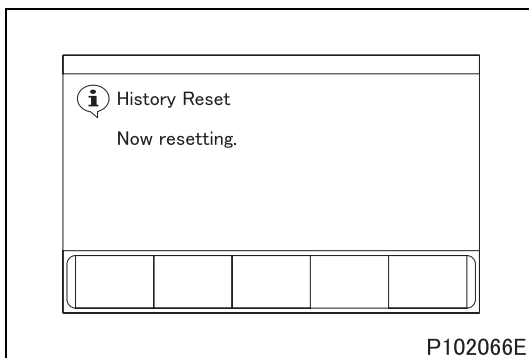

#### [History resetting] screen

- During resetting, do nothing and wait for a while.

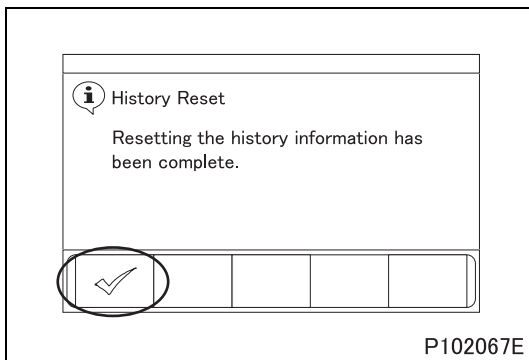

#### [History reset completed] screen

- This screen will appear when resetting of the history has finished. Click “OK” button and return to [History reset] screen.

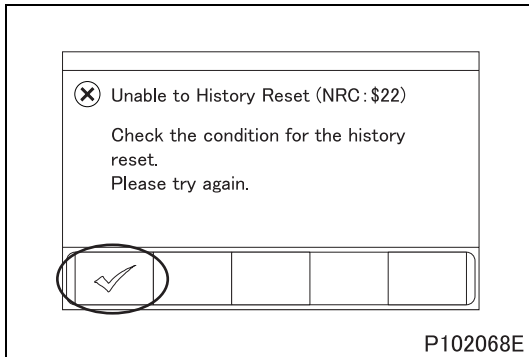

#### [History reset condition error] screen

- This screen will appear when a failure signal is sent from the engine electronic control unit to the Multi-Use Tester during resetting.
- In this case, check if the Multi-Use Tester and the vehicle (engine electronic control unit) is connected correctly and if the conditions for the execution of this procedure are satisfied. Then click “OK” to return to the [History reset] screen.

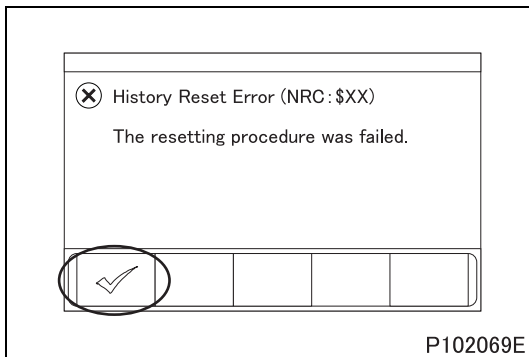

#### [History reset failed] screen

- This screen will appear when the communication error between Multi-Use Tester and the engine electronic control unit or the resetting error occurs.
- In this case, check if the Multi-Use Tester and the vehicle (engine electronic control unit) is connected correctly and if the conditions for the execution of this procedure are satisfied. Then click “OK” to return to the [History reset] screen.

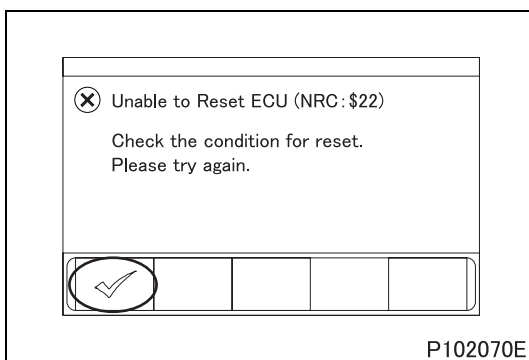

#### [ECU reset condition error] screen

- This screen will appear when a execution failure signal is sent from the engine electronic control unit to the Multi-Use Tester during resetting.
- In this case, recheck the conditions of the vehicle and retry from the beginning.
- Click “OK” to return to the [History reset] screen.

# TURBOCHARGER

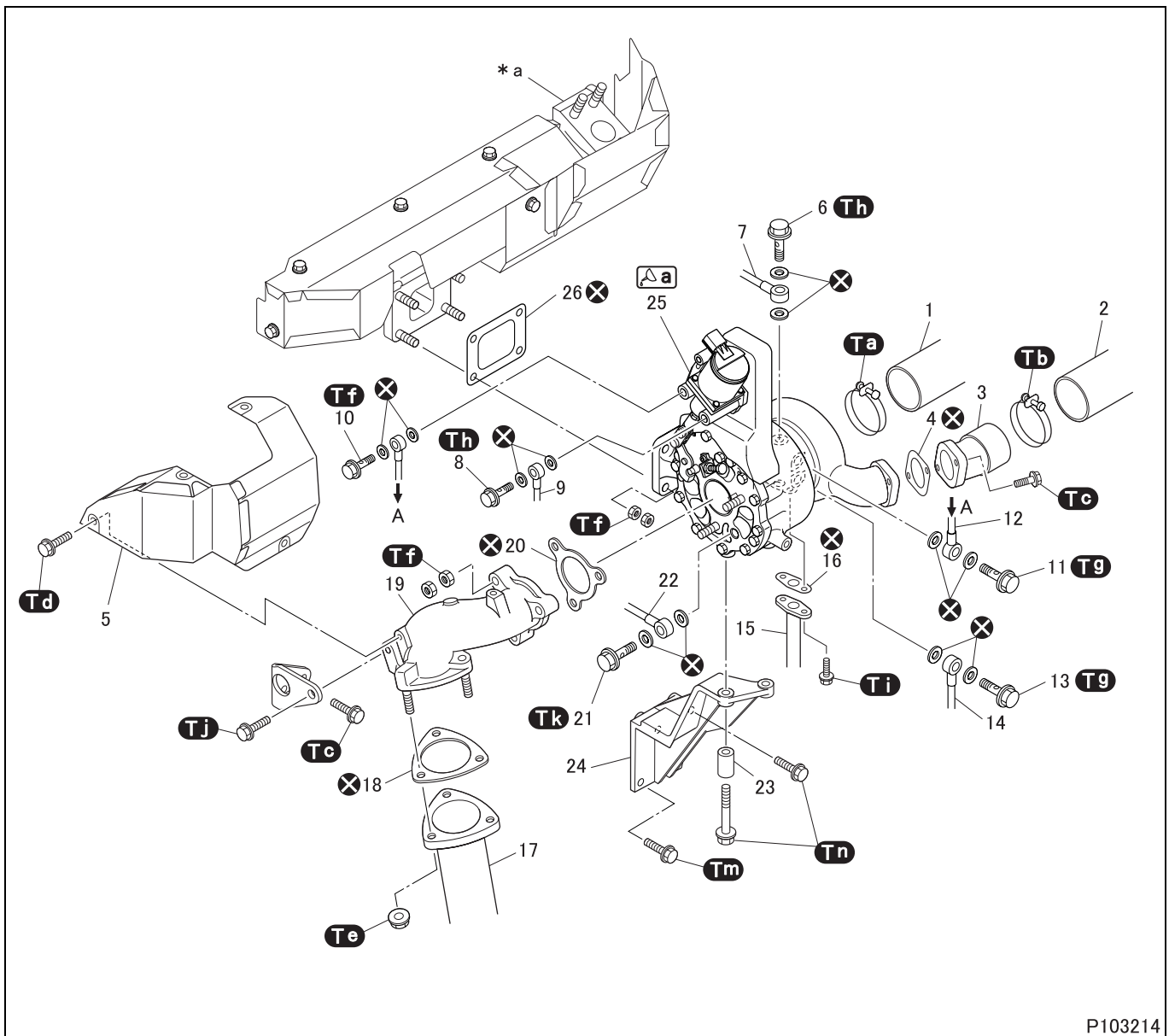

P103214

## ● Removal sequence

- |                        |                                      |
|------------------------|--------------------------------------|
| 1 Air duct             | 16 Gasket                            |
| 2 Air inlet hose       | 17 Front pipe                        |
| 3 Turbocharger coupler | 18 Gasket                            |
| 4 Gasket               | 19 Exhaust coupler                   |
| 5 Insulator            | 20 Gasket                            |
| 6 Eyebolt              | 21 Eyebolt                           |
| 7 Oil pipe             | 22 Air pipe                          |
| 8 Eyebolt              | 23 Spacer                            |
| 9 Water pipe           | 24 Bracket                           |
| 10 Eyebolt             | 25 Turbocharger (See later section.) |
| 11 Eyebolt             | 26 Gasket                            |
| 12 Water pipe          |                                      |
| 13 Eyebolt             |                                      |
| 14 Water pipe          |                                      |
| 15 Oil return pipe     |                                      |
- \*a: Exhaust manifold  
 X: Non-reusable parts

● **Installation sequence**

Follow the removal sequence in reverse.

**Tightening torque (Unit: N·m {ft.lbs, kgf·m})**

Mark	Parts to be tightened	Tightening torque	Remarks
<b>Ta</b>	Clamp	3 to 3.4 {2.2 to 2.5, 0.3 to 0.35}	–
<b>Tb</b>	Clamp	3.9 to 4.9 {2.9 to 3.6, 0.4 to 0.5}	–
<b>Tc</b>	Bolt (turbocharger coupler mounting)	24 {18, 2.4}	–
	Bolt (exhaust coupler stay mounting)		
<b>Td</b>	Bolt (insulator mounting)	20 {15, 2.0}	–
<b>Te</b>	Nut (front pipe mounting)	25 to 30 {18 to 22, 2.5 to 3.1}	–
<b>Tf</b>	Nut (exhaust coupler mounting)	50 {37, 5.1}	–
	Nut (turbocharger mounting)		
<b>Tg</b>	Eyebolt (water pipe mounting)	26 {19, 2.7}	–
<b>Th</b>	Eyebolt (water pipe mounting)	21 {15, 2.1}	–
	Eyebolt (oil pipe mounting)		
<b>Ti</b>	Bolt (oil pipe mounting)	5 {3.7, 0.5}	–
<b>Tj</b>	Bolt (exhaust coupler stay mounting)	42 {31, 4.3}	–
<b>Tk</b>	Eyebolt (air pipe mounting)	39 {29, 4.0}	–
<b>Tm</b>	Bolt (bracket mounting)	64 {47, 6.5}	–
<b>Tn</b>	Bolt (turbocharger mounting)	33 {24, 3.4}	–
	Bolt (bracket mounting)		

**Lubricant and/or sealant**

Mark	Points of application	Specified lubricant and/or sealant	Quantity
<b>△a</b>	Pouring into turbocharger	Engine oil	As required

**Special tools**

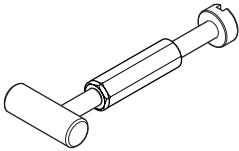
Mark	Tool name and shape	Part No.	Application
<b>Ca</b>	Jack 	MH063952	Displacement of engine

P106941

◆ **Work before removal** ◆

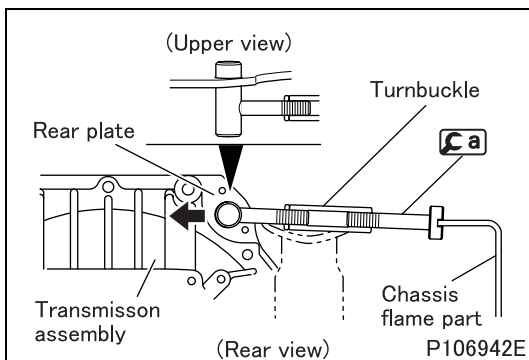

■ **Preparing for engine removal: Installation of jack**

- This work should be performed only if there isn't sufficient space around the turbocharger for removal and installation of it.
- Fit **Ca** between the chassis frame and the rear plate of the engine.
- Turn the turnbuckle of **Ca** with a wrench and shift the engine leftward by approximately 5 to 15 mm to make the space sufficient for removing and installing the turbocharger.

# TURBOCHARGER

## ◆ Installation procedure ◆

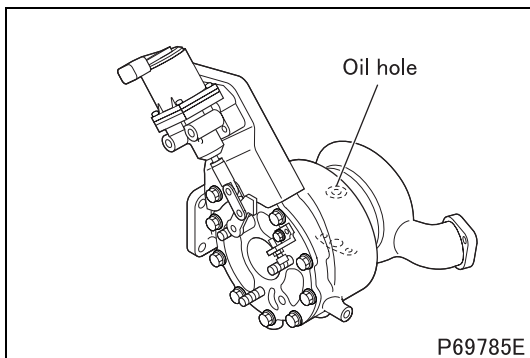

### ■ Installation: Turbocharger

- Before installing the turbocharger assembly, pour engine oil into the oil hole to ensure smooth operation of the internal parts.

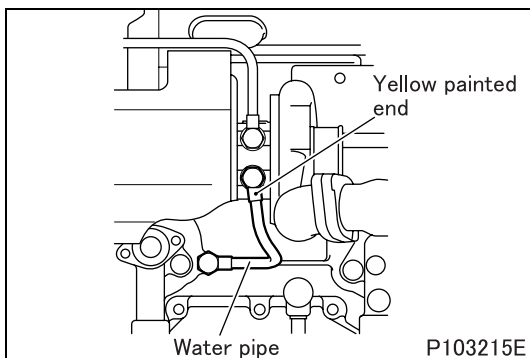

### ■ Installation: Water pipe

- Install the water pipe with its yellow painted end toward the turbocharger.

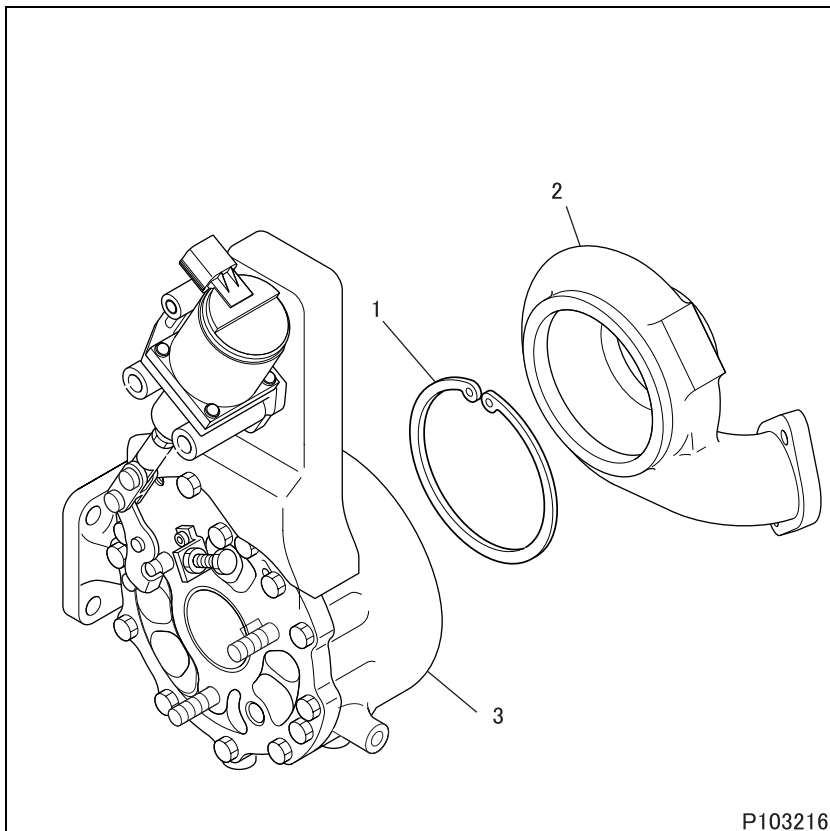

### ● Removal sequence

- 1 Snap ring
- 2 Compressor cover
- 3 Turbine assembly

- Do not unseal and try to adjust the turbine assembly. It should be replaced as an assembly if any failure is found.

### CAUTION ⚠

- The blades on the turbine assembly are easily bent. Make sure that they do not strike the compressor cover.
- The turbine assembly is a non-disassemble component. When it becomes unsmooth in rotation or has a damaged compressor wheel, replace the turbocharger.

### ● Installation sequence

Follow the removal sequence in reverse.



## Service standards (Unit: mm {in.})

Location	Maintenance item	Standard value	Limit	Remedy
3	Play in shaft axis direction of turbine assembly	0.39 to 0.67 {0.015 to 0.026}	–	Replace

### ◆ Work after disassembly ◆

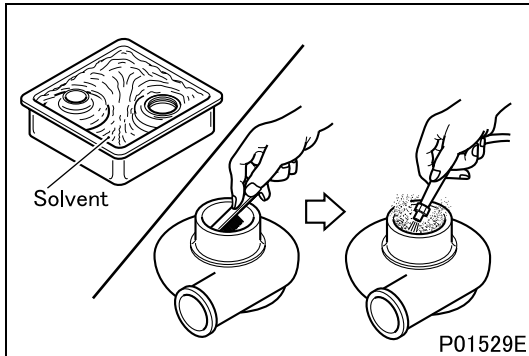

#### ■ Cleaning

- Before cleaning, visually check the disassembled parts for scorches, abrasion and other marks that may be difficult to see after cleaning. Replace any part that appears defective.
- Immerse the disassembled parts in a non-flammable solvent (a 5 to 10 aqueous solution of Oil Clean from New Hope Co., Ltd.). Take out the parts and blow them dry with compressed air. Remove any hard deposits with a stiff brush or plastic scraper.

#### CAUTION ⚠

- **Do not immerse the cartridge assembly in the solvent. Doing so will cause the O-ring inside the cartridge assembly to sell up, which may adversely affect turbocharger operation.**

- Again, immerse the parts in the solvent.
- Blow them dry using compressed air.

### ◆ Inspection procedure ◆

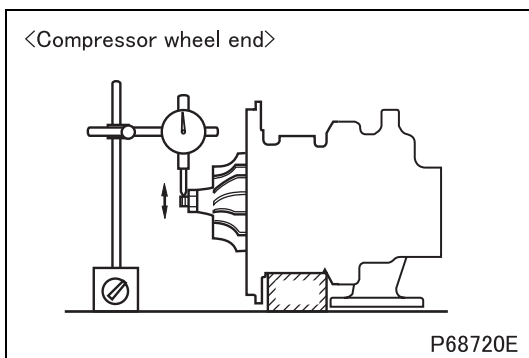

#### ■ Inspection: Play in shaft axis direction of turbine assembly

- With the flange of the turbine assembly attached to a flat plate, measure the play with a dial gauge.
- If the measurement exceeds the specified limit, replace the turbine assembly.

# INTERCOOLER

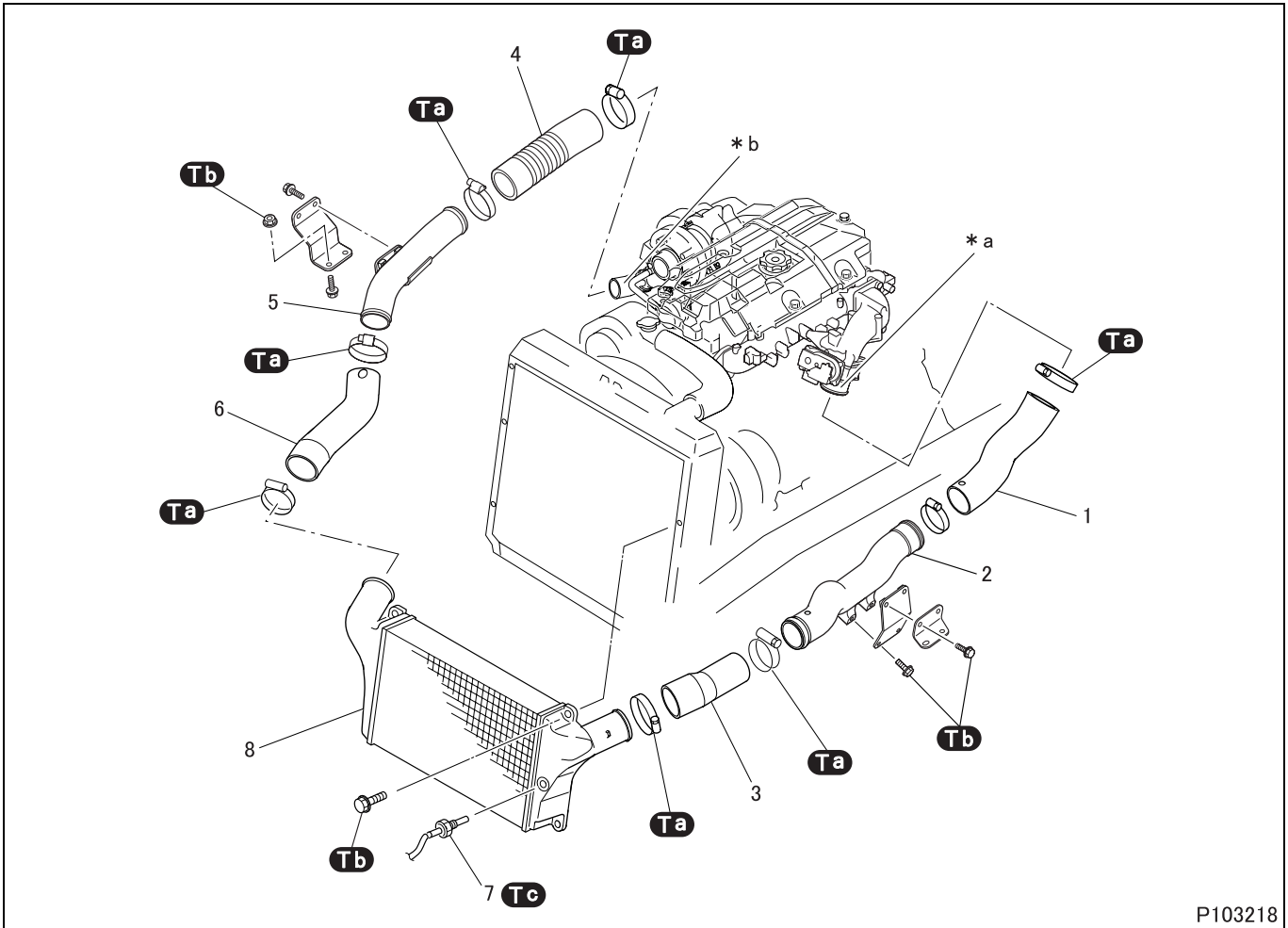

## ● Disassembly sequence

- |                     |                                 |                          |
|---------------------|---------------------------------|--------------------------|
| 1 Air inlet hose    | 5 Air inlet pipe RH             | *a: Intake throttle      |
| 2 Air inlet pipe LH | 6 Air inlet hose                | *b: Turbocharger coupler |
| 3 Air inlet hose    | 7 Intake air temperature sensor |                          |
| 4 Air inlet hose    | 8 Intercooler                   |                          |

## CAUTION

- Do not remove forcibly the air inlet hose using a screwdriver or other similar tool. Doing so could damage the fluorine treatment layer on the inside surface of the hose, deteriorating the resistance to oil of the hose.

## ● Assembly sequence

Follow the disassembly sequence in reverse.

## Service standards

Location	Maintenance item	Standard value	Limit	Remedy
8	Intercooler air leakage (air pressure: 200 kPa {29 psi, 2.0 kgf/cm <sup>2</sup> } maintained for 30 seconds)	0 cm <sup>3</sup> {0 cu.in.}	–	Replace

**Tightening torque (Unit: N·m {ft.lbs, kgf·m})**

Mark	Parts to be tightened	Tightening torque	Remarks
<b>Ta</b>	Clamp	3.9 to 4.9 {2.9 to 3.6, 0.4 to 0.5}	–
<b>Tb</b>	Bolt (bracket mounting)	12 to 15 {8.9 to 11, 1.2 to 1.5}	–
	Nut (bracket mounting)		
	Bolt (intercooler mounting)		
<b>Tc</b>	Intake air temperature sensor	14.7 to 24.5 {11 to 18, 1.5 to 2.5}	–

**◆ Inspection procedure ◆**

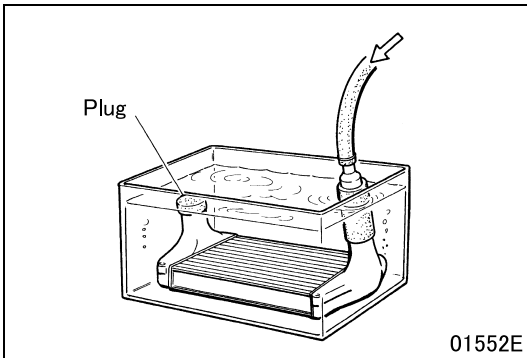

**■ Inspection: Intercooler**

- Plug one of the air ports on the intercooler and connect an air source to the other port. Place the intercooler in a tank of water and apply air pressure of the specified level (200 kPa {29 psi, 2.0 kgf/cm<sup>2</sup>}) to the intercooler and retain the pressure for 30 seconds.
- Replace the intercooler if any air leakage is evident.

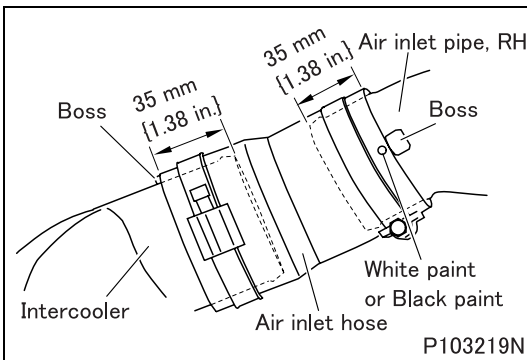

**■ Installation: Air inlet hose**

- Connect the air inlet hose to the RH air inlet pipe with the white paint on the hose aligned with the boss on the pipe.
- Connect the air inlet hoses to the intercooler, RH air inlet pipe and turbocharger coupler to the dimensions indicated in the illustrations.

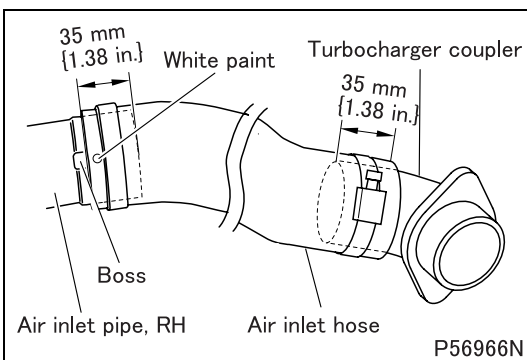

# INTERCOOLER

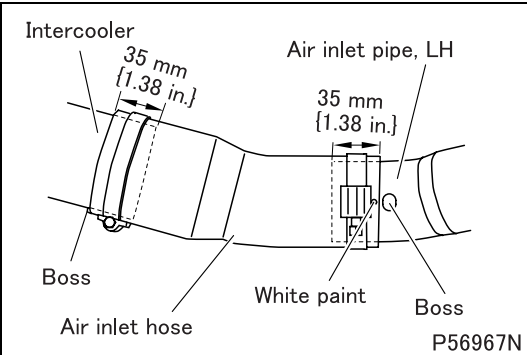

- Connect the air inlet hose to the LH air inlet pipe with the white paint on the hose aligned with the boss on the pipe.
- Connect the air inlet hoses to the intercooler, LH air inlet pipe and air inlet duct to the dimensions indicated in the illustrations.

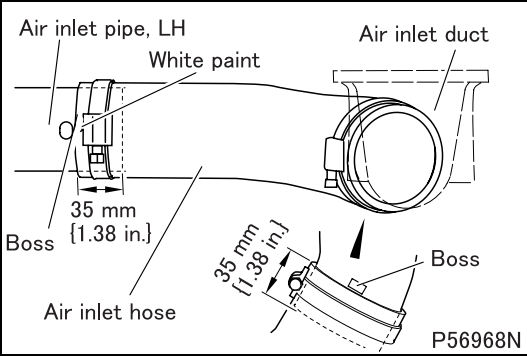

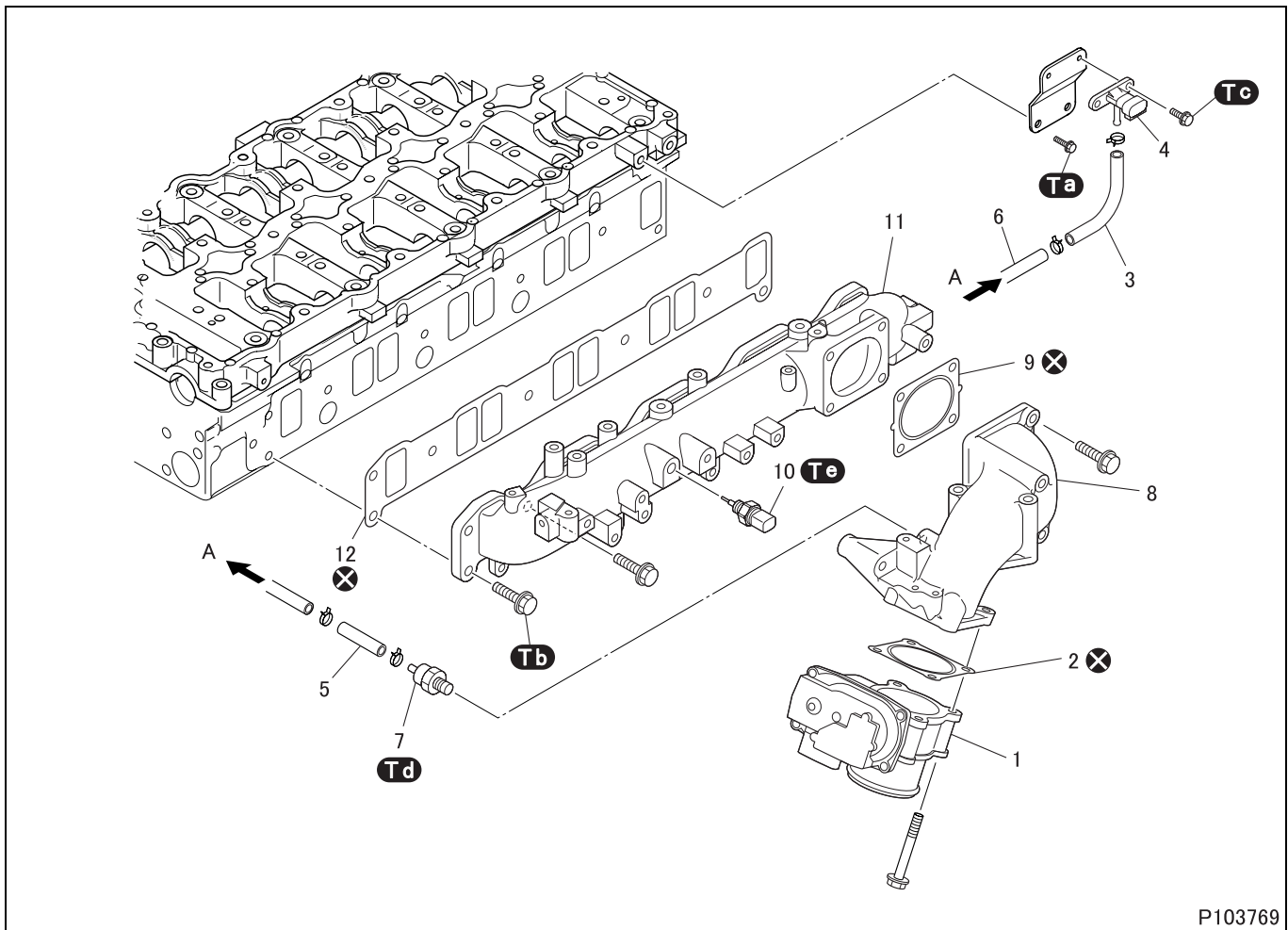

P103769

## ● Disassembly sequence

- |                         |                                 |                       |
|-------------------------|---------------------------------|-----------------------|
| 1 Intake throttle       | 6 Vacuum pipe                   | 11 Intake manifold    |
| 2 Gasket                | 7 Gas filter                    | 12 Gasket             |
| 3 Vacuum hose           | 8 Air inlet pipe                |                       |
| 4 Boost pressure sensor | 9 Gasket                        | ⊗: Non-reusable parts |
| 5 Vacuum hose           | 10 Boost air temperature sensor |                       |

## ● Assembly sequence

Follow the disassembly sequence in reverse.

## Tightening torque (Unit: N·m {ft.lbs, kgf·m})

Mark	Parts to be tightened	Tightening torque	Remarks
<b>Ta</b>	Bolt (boost pressure sensor bracket mounting)	24 {18, 2.4}	—
<b>Tb</b>	Bolt (intake manifold mounting)	46 {34, 4.7}	—
<b>Tc</b>	Bolt (boost pressure sensor mounting)	5.5 {4.1, 0.6}	—
<b>Td</b>	Gas filter	14.7 to 19.6 {11 to 14, 1.5 to 2.0}	—
<b>Te</b>	Boost air temperature sensor	25 {18, 2.5}	—

# INTAKE MANIFOLD

## ◆ INSTALLATION procedure ◆

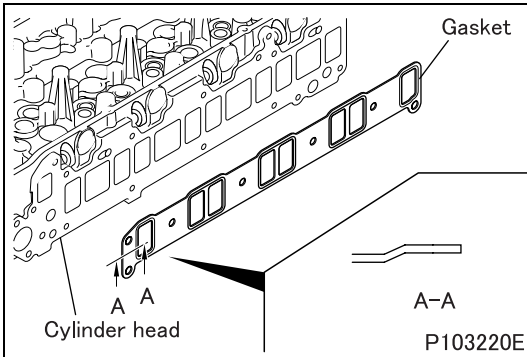

## ◆ Inspection procedure ◆

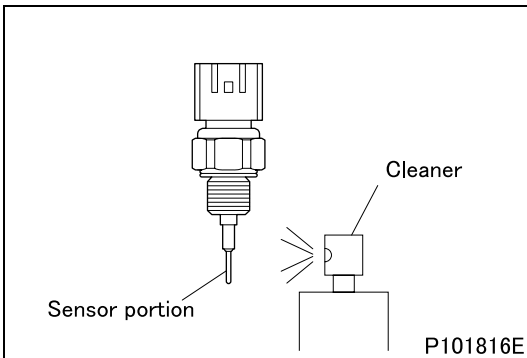

### ■ Installation: Gasket

- Install the gasket on the cylinder head in the illustrated direction.

### ■ Inspection: Boost air temperature sensor

- Check that the sensor portion is free of soot, oily substance, etc.
- If not, clean the sensor portion as follows.
- Spray a cleaner on the sensor portion from 2 or 3 cm {0.79 or 1.18 in.} away.  
Recommended cleaners:  
Nonchlorinated solvent
- In 20 to 30 seconds after spraying, wipe the sensor portion clear of the sprayed cleaner using a soft waste cloth the like.

### CAUTION ⚠

- **Be sure to wait for 20 to 30 seconds before wiping. It takes the cleaner that long to dissolve foreign matter.**

- If the sensor portion is fouled excessively, the positive crankcase ventilation (PCV) may be faulty. Inspect the PCV valve and filter to locate the cause and remove it.

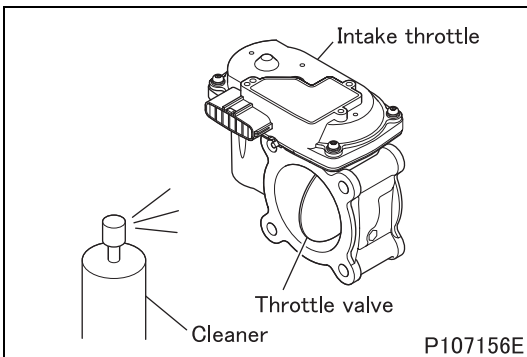

### ■ Inspection: Intake throttle

- Check that the throttle valve is free of soot, oily substance, etc.
- If not, clean the throttle valve as follows.
- Spray a cleaner on the throttle valve from 2 or 3 cm {0.79 or 1.18 in.} away.  
Recommended cleaners:  
Nonchlorinated solvent
- In 20 to 30 seconds after spraying, wipe the throttle valve clear of the sprayed cleaner using a soft waste cloth the like.

### CAUTION ⚠

- **Be sure to wait for 20 to 30 seconds before wiping. It takes the cleaner that long to dissolve foreign matter.**
- **Do not spray a cleaner on the intake throttle connector directly. If it is sprayed on the connector, immediately wipe it off.**

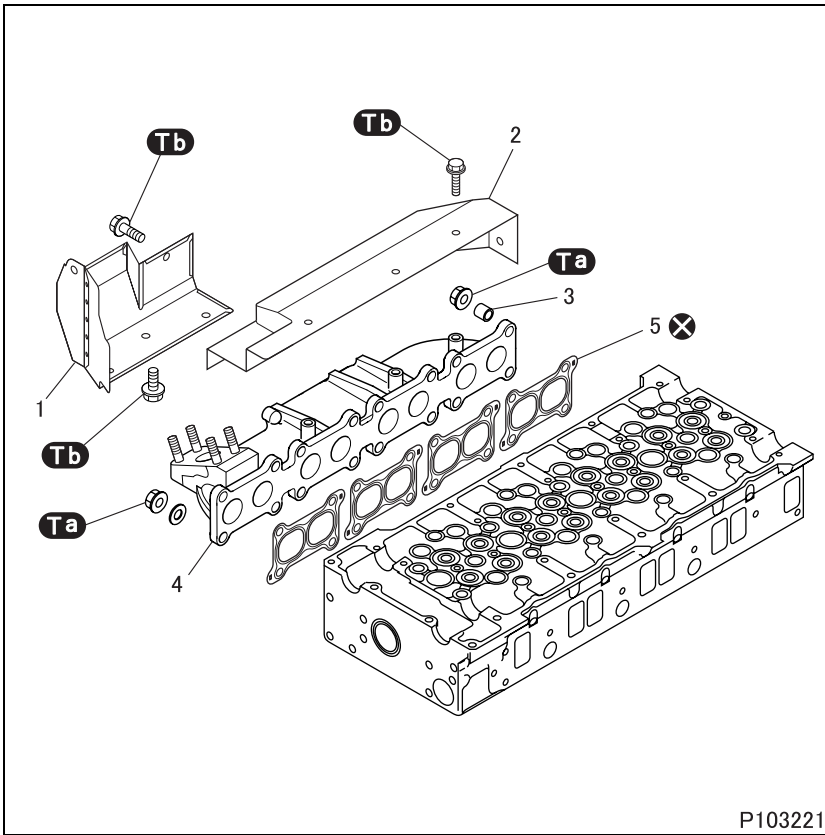

### ● Disassembly sequence

- 1 Exhaust manifold insulator
- 2 Exhaust manifold insulator
- 3 Distance piece
- 4 Exhaust manifold
- 5 Gasket

⊗: Non-reusable parts

### ● Assembly sequence

Follow the disassembly sequence in reverse.

### Tightening torque (Unit: N·m {ft.lbs, kgf·m})

Mark	Parts to be tightened	Tightening torque	Remarks
<b>Ta</b>	Nut (exhaust manifold mounting)	42 {31, 4.3}	—
<b>Tb</b>	Bolt (exhaust manifold insulator mounting)	20 {15, 2.0}	—

### ◆ Installation procedure ◆

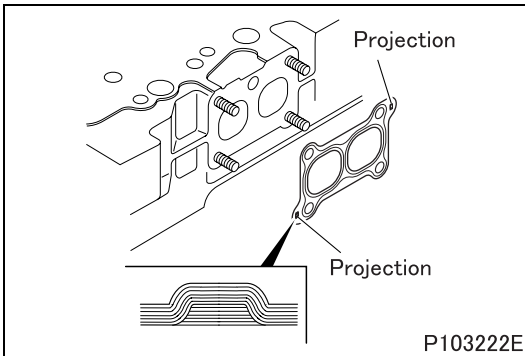

### ■ Installation: Gasket

- Install the gasket on the cylinder head with their surfaces facing in the illustrated directions.

# EXHAUST PIPE

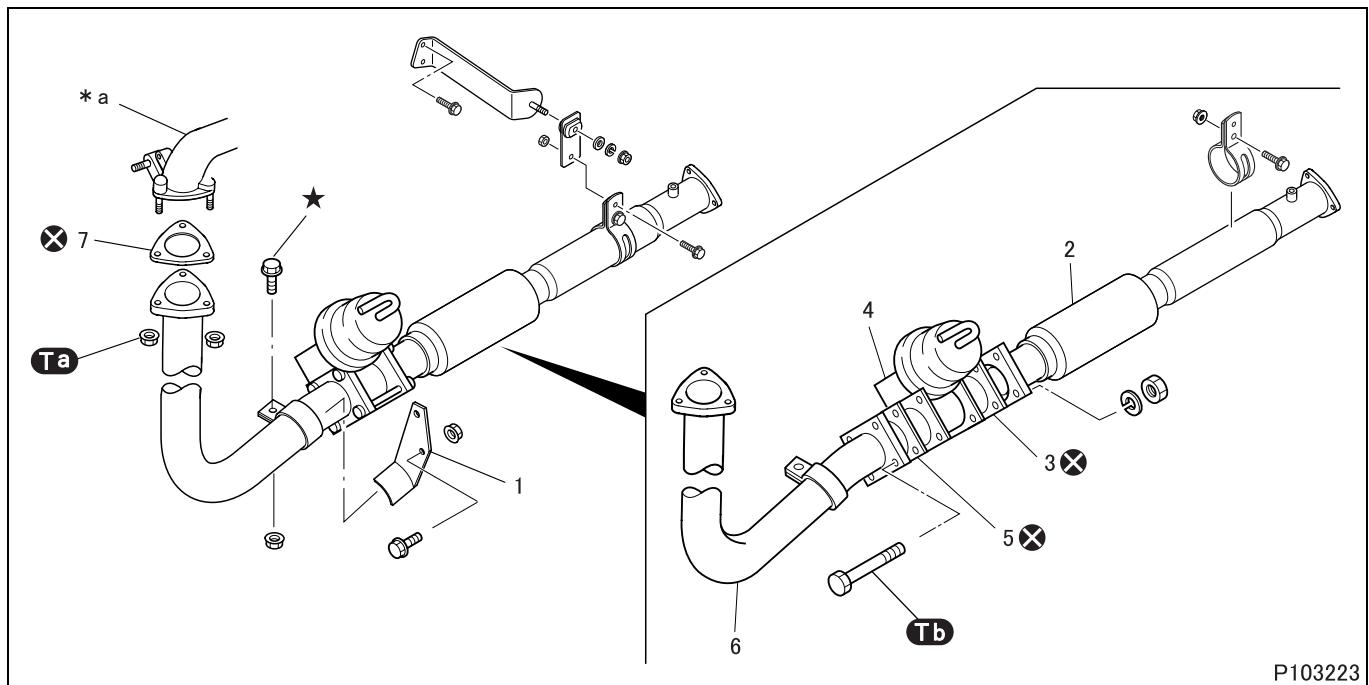

## ● Disassembly sequence

- |   |               |   |                                    |     |                    |
|---|---------------|---|------------------------------------|-----|--------------------|
| 1 | Brace bracket | 4 | Exhaust brake unit<br>(See Gr35A.) | 7   | Gasket             |
| 2 | Front pipe    | 5 | Gasket                             | *a: | Exhaust coupler    |
| 3 | Gasket        | 6 | Front pipe                         | ⊗:  | Non-reusable parts |

## CAUTION

- Loosen the ★ marked bolt first to prevent undue forces from being applied to the exhaust pipe.

## ● Assembly sequence

Follow the disassembly sequence in reverse.

## CAUTION

- Tighten the ★ marked bolt last to prevent undue forces from being applied to the exhaust pipe.

## Tightening torque (Unit: N·m {ft.lbs, kgf·m})

Mark	Parts to be tightened	Tightening torque	Remarks
Ta	Nut (front pipe mounting)	25 to 30 {18 to 22, 2.5 to 3.1}	-
	Bolt (front pipe mounting)		
Tb	Bolt (exhaust brake unit mounting)	25 to 28 {18 to 21, 2.5 to 2.9}	-

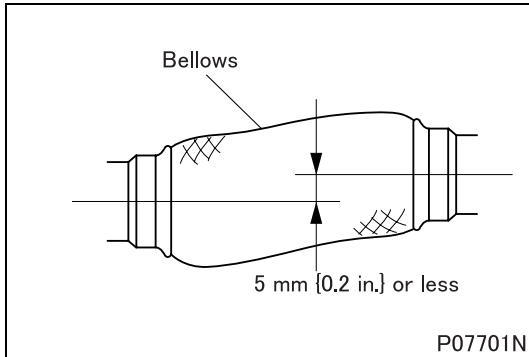

**◆ Installation procedure ◆****■ Installation: Front pipe**

- Install the front pipe so that the amounts of offset in both vertical and horizontal directions between the pipes in front of and behind the bellows are smaller than the dimension indicated in the illustration.

**CAUTION** 

- The bellows on the front pipe have the purpose of reducing the level of noise from the vehicle. It is not intended for compensating for misalignment that may result from improper installation of the front pipe. Install the front pipe properly to avoid excessive tension or other stress on the bellows.

# DIESEL PARTICULATE FILTER

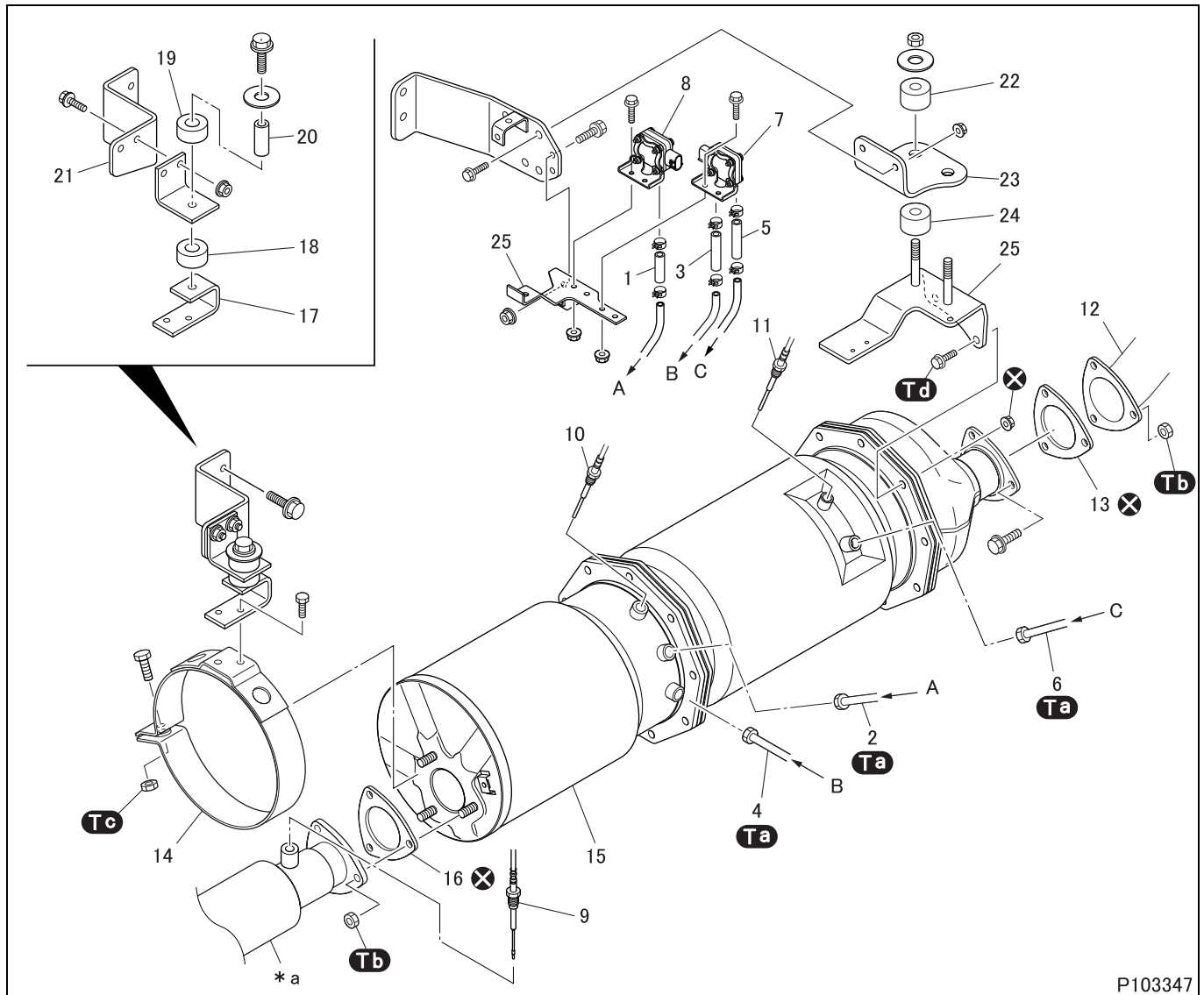

## ● Removal sequence

- |                                |                             |                                |
|--------------------------------|-----------------------------|--------------------------------|
| 1 Pressure hose                | 10 DPF temperature sensor 1 | 20 Collar                      |
| 2 Pressure pipe                | 11 DPF temperature sensor 2 | 21 Bracket                     |
| 3 Pressure hose                | 12 Tail pipe                | 22 Cushion rubber              |
| 4 Pressure pipe                | 13 Gasket                   | 23 Bracket                     |
| 5 Pressure hose                | 14 DPF band                 | 24 Cushion rubber              |
| 6 Pressure pipe                | 15 DPF (See later section.) | 25 Bracket                     |
| 7 DPF pressure sensor (DIFF)   | 16 Gasket                   |                                |
| 8 DPF absolute pressure sensor | 17 Stay                     | *a: Front pipe                 |
| 9 Catalytic temperature sensor | 18 Cushion rubber           | ⊗: Non-reusable parts          |
|                                | 19 Cushion rubber           | DPF: Diesel particulate filter |

## ● Installation sequence

Follow the removal sequence in reverse.

## Tightening torque (Unit: N·m {ft.lbs, kgf·m})

Mark	Parts to be tightened	Tightening torque	Remarks
<b>Ta</b>	Pressure pipe	40 {30, 4.0}	–
<b>Tb</b>	Nut (front pipe mounting)	26 to 33 {2.0 to 24, 2.7 to 3.4}	–
	Nut (tail pipe mounting)		
<b>Tc</b>	Nut (diesel particulate filter band mounting)	45 to 55 {33 to 4.1, 4.5 to 5.6}	–
<b>Td</b>	Bolt (bracket mounting)	49 to 63.7 {36 to 47, 5.0 to 6.4}	–

### ◆ Inspection procedure ◆

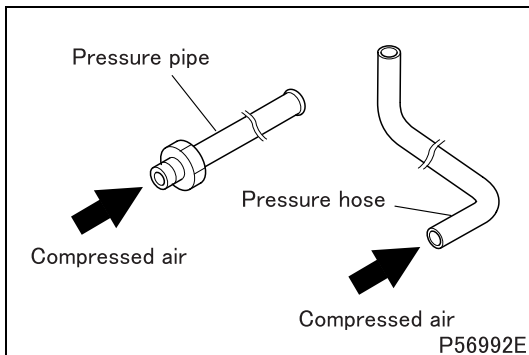

#### ■ Inspection: Pressure pipe and hose

- Check the pressure pipe and hose for clogging by blowing compressed air into the pipe and hose.

#### CAUTION ⚠

- Inspection must be performed on an individual pressure pipe or hose.
- If compressed air is blown into the pressure pipe or hose with diesel particulate filter pressure sensor still installed, the sensor may become damaged.

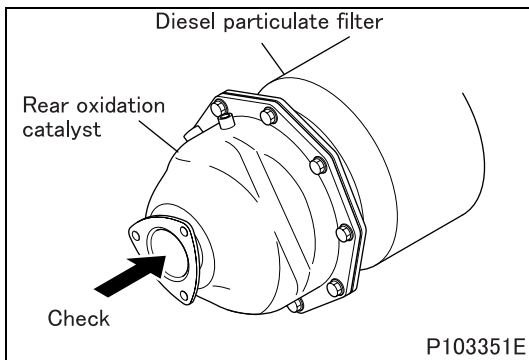

#### ■ Inspection: Diesel particulate filter

- Check the inside of the rear oxidation catalyst and the diesel particulate filter for adhesion of soot.
- If a large amount of soot is adhered, replace the ceramic filter as it may be damaged.

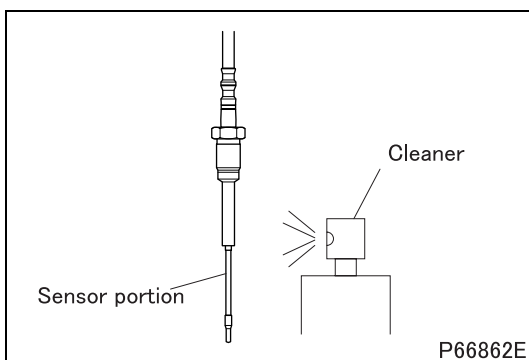

#### ■ Inspection: Temperature sensor

- Check that the sensor portion is free of soot, oily substance, etc.
- If not, clean the sensor portion as follows.
- Spray a cleaner on the sensor portion from 2 or 3 cm {0.79 or 1.18 in.} away.  
Recommended cleaners:  
Nonchlorinated solvent
- In 20 to 30 seconds after spraying, wipe the sensor portion clear of the sprayed cleaner using a soft waste cloth the like.

#### CAUTION ⚠

- Be sure to wait for 20 to 30 seconds before wiping. It takes the cleaner that long to dissolve foreign matter.

# DIESEL PARTICULATE FILTER

## ◆ Installation procedure ◆

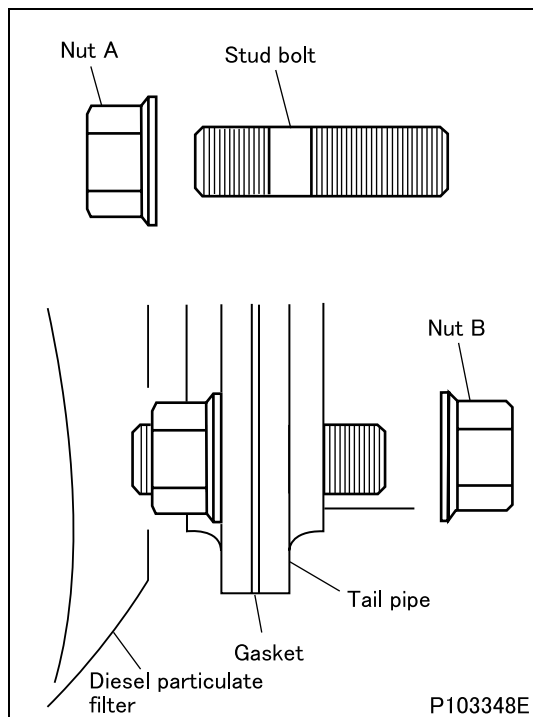

### ■ Installation: Tail pipe

- Install nut A to the shorter thread end of a stud bolt. Tighten the nut fully.
- From the diesel particulate filter side, insert the assembled stud bolt and nut A into the bolt hole. Fit the gasket and the tail pipe and tighten nut B to the specified torque.

DPF

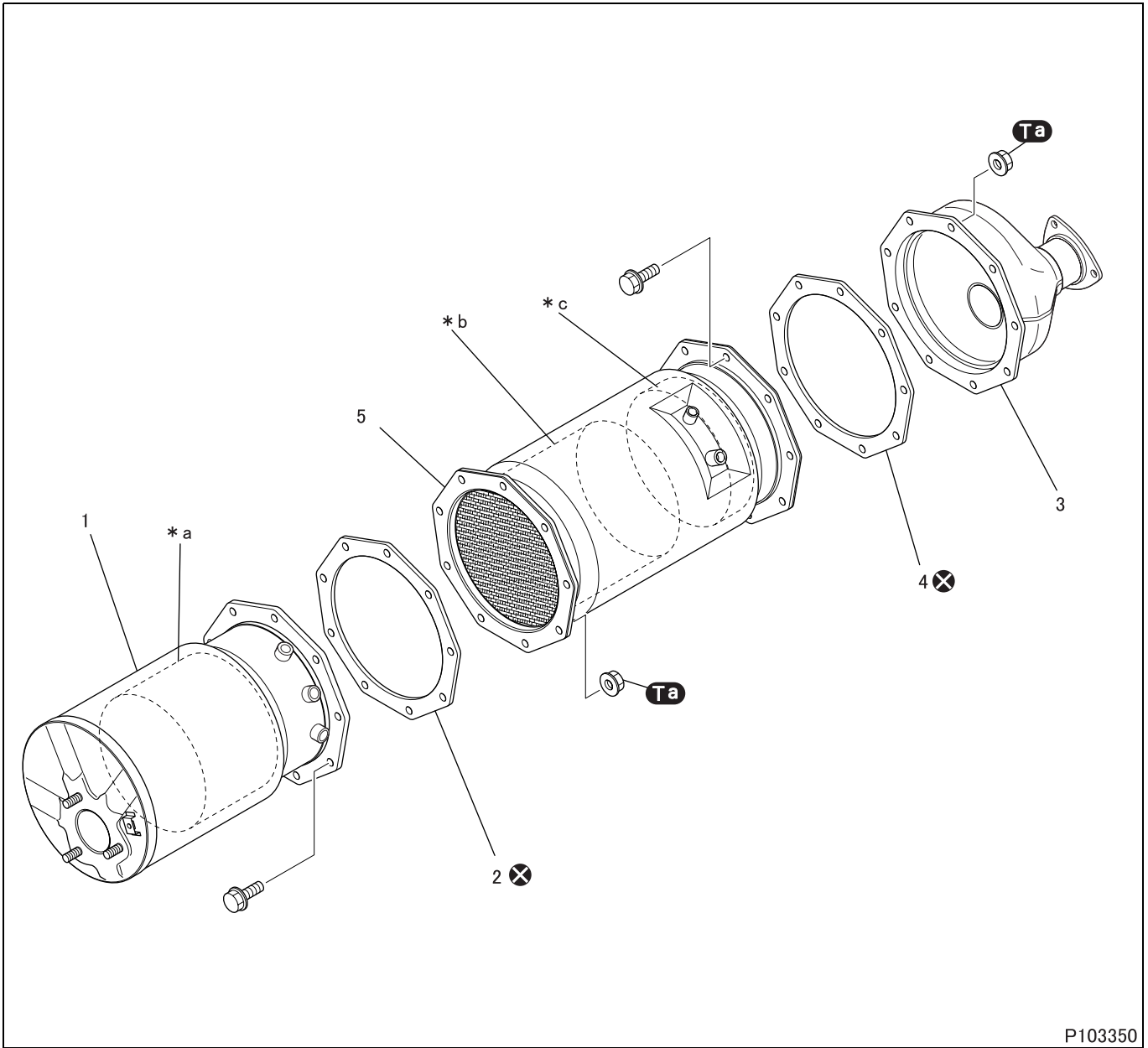

P103350

● Disassembly sequence

- 1 Inlet body
- 2 Gasket
- 3 Outlet body

- 4 Gasket
- 5 Filter body

- \*a: Front oxidation catalyst
- \*b: Ceramic filter
- \*c: Rear oxidation catalyst
- ⊗: Non-reusable parts

● Assembly sequence

Follow the disassembly sequence in reverse.

Tightening torque (Unit: N·m {ft.lbs, kgf·m})

Mark	Parts to be tightened	Tightening torque	Remarks
Ta	Nut (inlet body mounting)	49 to 63.7 {36 to 47, 5.0 to 6.4}	-
	Nut (outlet body mounting)		

# DIESEL PARTICULATE FILTER

## ◆ Inspection procedure ◆

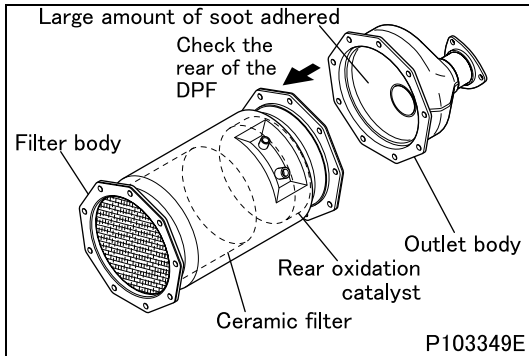

### ■ Inspection: Inlet body

- Visually inspect the front oxidation catalyst.
- If there is any abnormality or damage, replace the inlet body.

### ■ Inspection: Outlet body

- Check if a large amount of soot adheres inside the diesel particulate filter outlet body.
- If a large amount of soot adhesion is found, replace the diesel particulate filter.

### ■ Inspection: Filter body

- Check the rear oxidation catalyst at the rear of the ceramic filter for damage.
- If any abnormality is found, replace the filter body.
- If no abnormality is found but cleaning of the filter is required, clean the ceramic filter. (See "DIESEL PARTICULATE FILTER INSPECTION".)