INDEX

STRUCTURE AND OPERATION

- 1. Exhaust Gas Recirculation System 17-2
- 2. Crankcase Emission Control System 17-7

EXHAUST GAS RECIRCULATION VALVE, PIPE AND COOLER 17-8

CRANKCASE EMISSION CONTROL SYSTEM 17-12

STRUCTURE AND OPERATION

1. Exhaust Gas Recirculation System

1.1 Overview

- In the exhaust gas recirculation system, the engine electronic control unit and multiple electronic drive units control the exhaust gas recirculation valve and intake throttle in accordance with information from sensors on various aspects of the engine (engine speed, coolant temperature, throttle opening, etc.).
- Exhaust gas recirculation involves the introduction of inert gases in the post-combustion exhaust emissions into the intake manifold. By reducing the combustion temperature, it reduces the amount of nitrogen oxides (NO_x), which are harmful, in the exhaust emissions. Further, an exhaust gas recirculation cooler cools the recirculated exhaust emissions, thereby reducing the peak combustion temperature.
- The intake air quantity is adjusted by means of intake throttle control such that the effectiveness of exhaust gas recirculation is maximized.

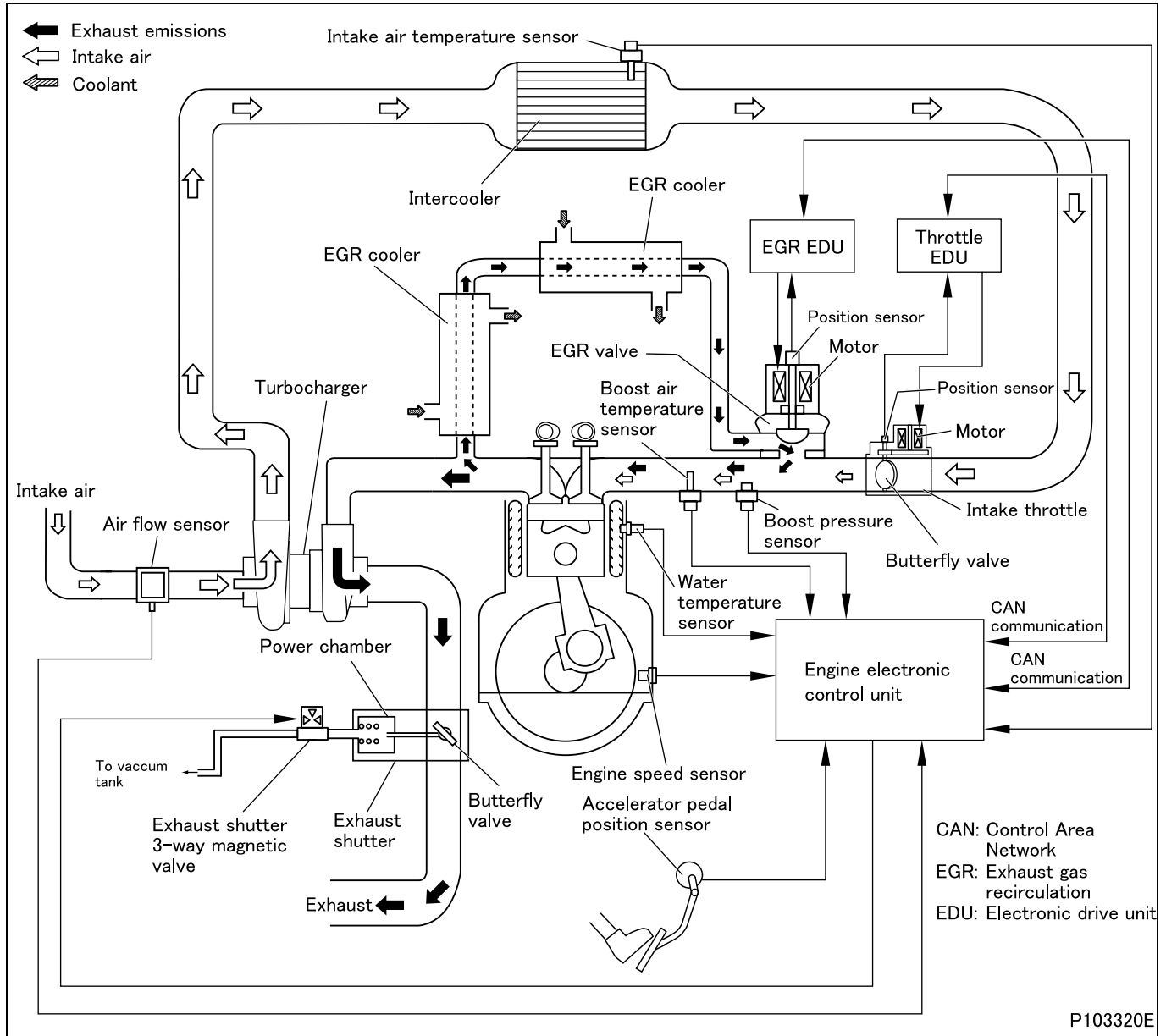

1.2 Electronic control system

(1) System block diagram

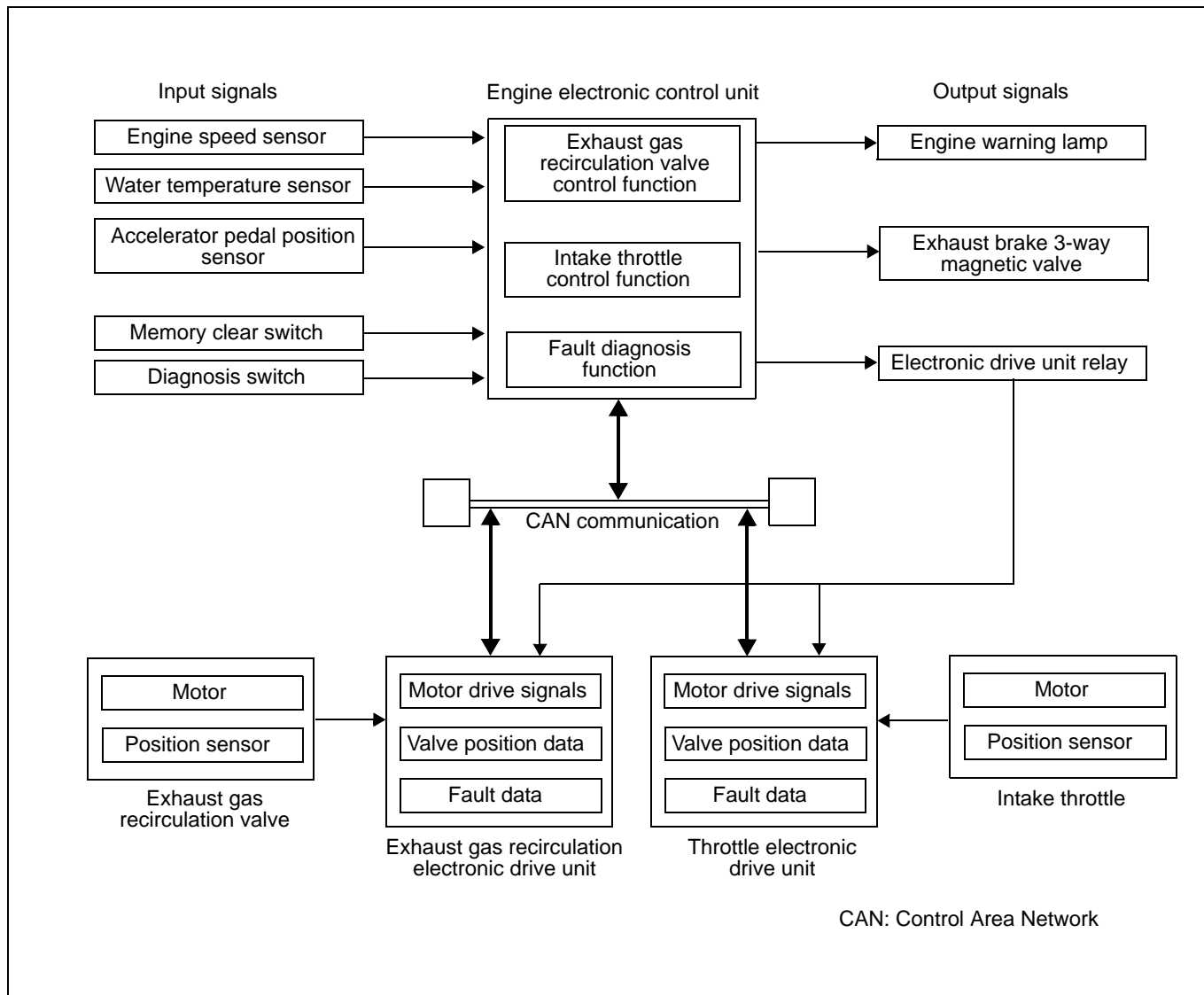

STRUCTURE AND OPERATION

(2) Exhaust gas recirculation valve control function

- In accordance with data from sensors, the engine electronic control unit determines the exhaust gas recirculation valve opening that suits the operating condition and sends a control signal (this indicates the target exhaust gas recirculation valve opening) to the exhaust gas recirculation electronic drive unit.
When necessary to prevent black smoke emissions and engine speed instability (for example, when the engine is heavily loaded, when the engine is lightly loaded, and when the exhaust brake is operating), the engine electronic control unit stops exhaust gas recirculation valve control.
- The exhaust gas recirculation electronic drive unit activates the exhaust gas recirculation valve motor. At the same time, it monitors the extent of valve lift using a position sensor and sends this information (this indicates the actual exhaust gas recirculation valve opening) to the engine electronic control unit.
This operation makes it possible for the target exhaust gas recirculation valve opening indicated by the engine electronic control unit to be precisely maintained.

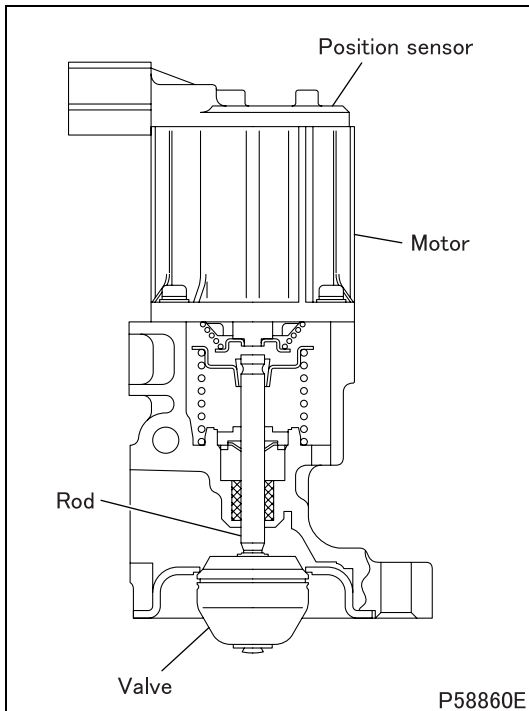

(2.1) Exhaust gas recirculation valve

- A motor in the exhaust gas recirculation valve is driven by control signals from the exhaust gas recirculation electronic drive unit. Via a rod, the motor's operation opens and closes the valve.

(3) Intake throttle control function

- When the engine electronic control unit determines from sensor data on the engine speed and engine loading that the vacuum pressure in the intake manifold is low, it increases the amount of exhaust emissions introduced into the intake manifold by determining an appropriate butterfly valve opening and by sending corresponding control signals (these indicate the target throttle opening) to the throttle electronic drive unit.
- The throttle electronic drive unit activates the valve motor. At the same time, it monitors the valve opening using a position sensor and sends this information (this indicates the actual throttle opening) to the engine electronic control unit.
This operation makes it possible for the target throttle opening indicated by the engine electronic control unit to be precisely maintained.

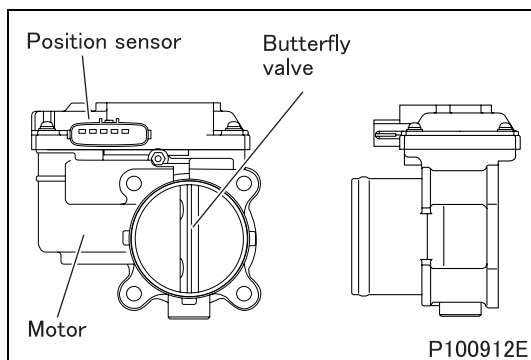

(3.1) Intake throttle

- In accordance with signals from the throttle electronic drive unit, the motor opens and closes the butterfly valve, thereby adjusting the intake air amount such that the effectiveness of exhaust gas recirculation is maximized.

(4) Fault diagnosis function

- While the starter switch is in the ON position, the engine electronic control unit continuously monitors the electronic drive units and sensors for faults. In the event that the engine electronic control unit finds a component faulty, it causes an indication to be made in the meter cluster to alert the driver. At the same time, it memorizes the fault location in the form of a diagnosis code and starts a control during fault.
- While the engine is running, the exhaust gas recirculation electronic drive unit and throttle electronic drive unit continuously monitor communication with the position sensor and motor of the exhaust gas recirculation valve, communication with the position sensor and motor of the intake throttle, and communication with the engine electronic control unit. In the event that they identify a fault, they send fault data to the engine electronic control unit.
- While control necessitated by a fault is taking place, the system's functionality is limited to ensure vehicle and driver safety. It is possible to read the memorized diagnosis code using a Multi-Use Tester or from flashing of the warning lamp.

NOTE

- **Diagnosis codes shown by the Multi-Use Tester and those indicated by flashing of the warning lamp are different.**
- **The Multi-Use Tester is capable of showing more detailed diagnosis codes.**

STRUCTURE AND OPERATION

1.3 Electronic control unit connection diagram

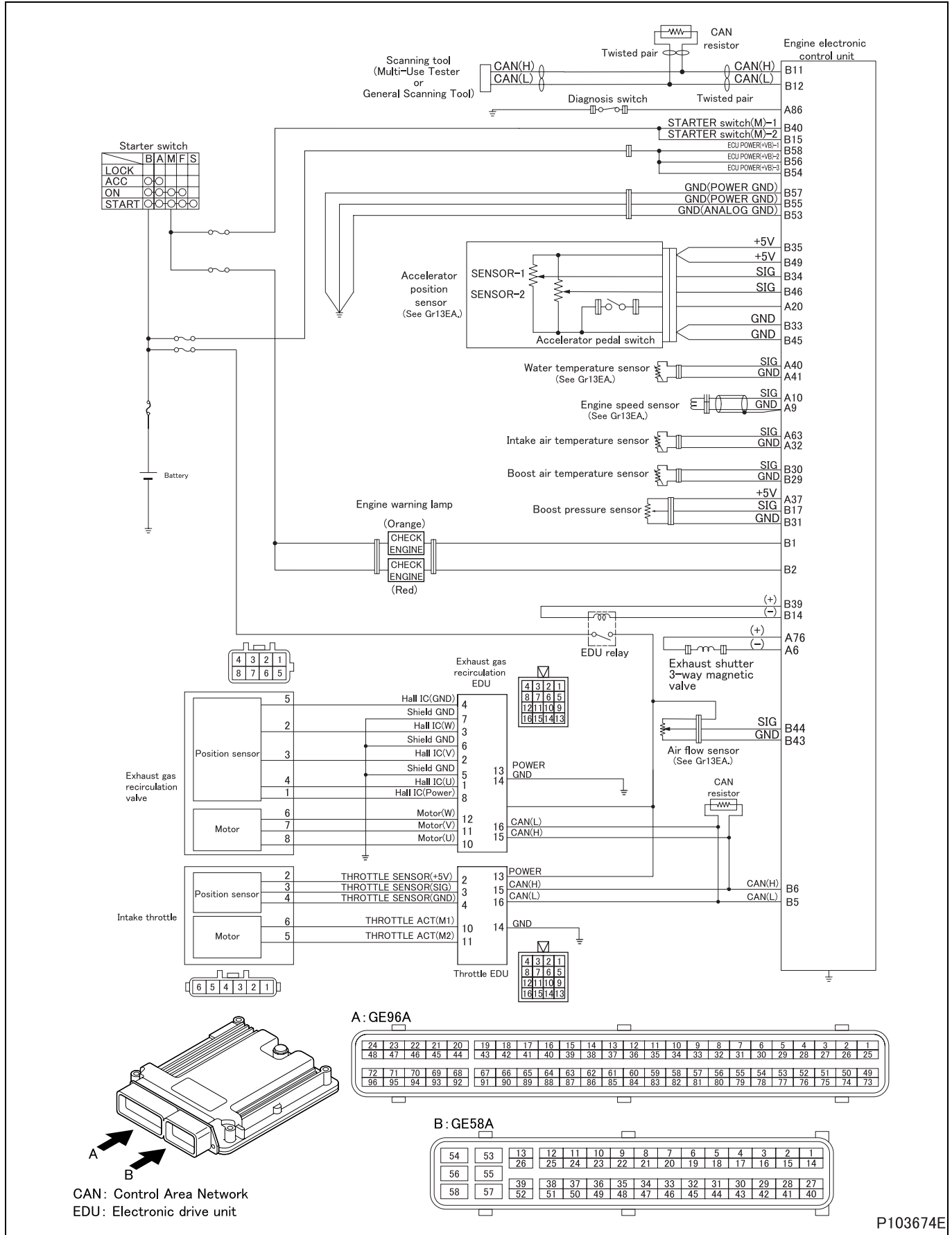

2. Crankcase Emission Control System

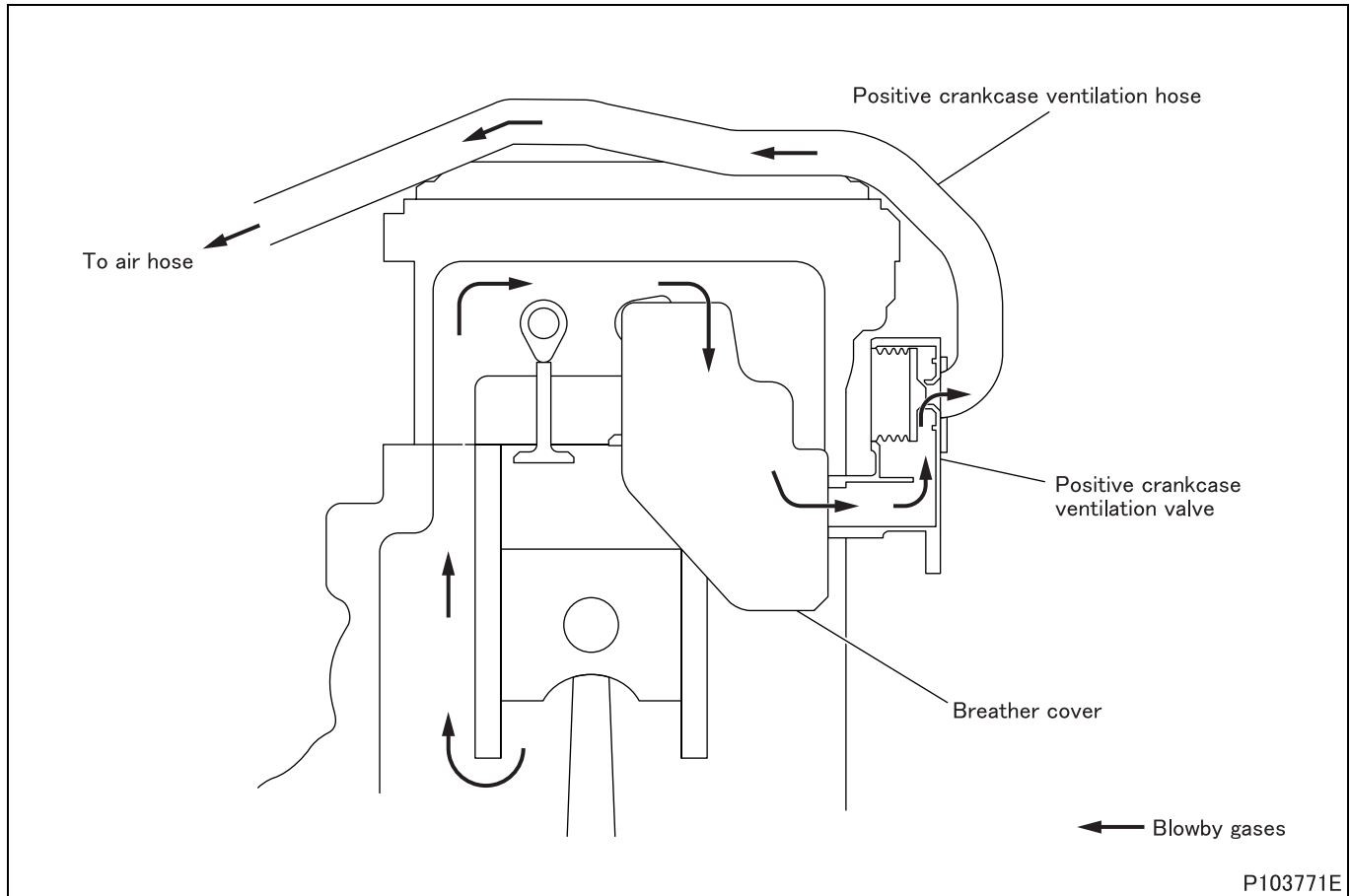

- The crankcase emission control system returns blowby gases to an air duct to prevent them from being released to the outside air.
- The positive crankcase ventilation valve keeps constant the pressure inside the crankcase.

Service standards

Location	Maintenance item	Standard value	Limit	Remedy	
10	Air leakage from EGR cooler	Leakage into coolant (air pressure: 300 kPa {44 psi, 3.1 kgf/cm ² })	0 cm ³ {0 mL}	-	Replace
		Leakage into exhaust gas (air pressure: 400 kPa {58 psi, 4.1 kgf/cm ² })	0 cm ³ {0 mL}		
17	Air leakage from EGR cooler	Leakage into coolant (air pressure: 196 kPa {28 psi, 2.0 kgf/cm ² })	0 cm ³ {0 mL}	-	Replace
		Leakage into exhaust gas (air pressure: 294 kPa {43 psi, 3.0 kgf/cm ² })	0 cm ³ {0 mL}		

Tightening torque (Unit: N·m {ft.lbs, kgf·m})

Mark	Parts to be tightened	Tightening torque	Remarks
Ta	Connector	58 {43, 5.9}	-
Tb	Bolt (EGR pipe A mounting)	24 {18, 2.5}	-
	Bolt (EGR pipe C mounting)		
	Bolt (EGR cooler mounting)		
Tc	Nut (EGR cooler mounting)	41 {30, 4.2}	-
Td	Bolt (EGR cooler bracket mounting)	28 {21, 2.9}	-
Te	Bolt (EGR valve mounting)	46 {34, 4.7}	-
	Bolt (EGR pipe C mounting)		
	Bolt (EGR cooler bracket mounting)		
Tf	Bolt (EGR cooler insulator mounting)	20 {15, 2.0}	-

Lubricant and/or sealant

Mark	Points of application	Specified lubricant and/or sealant	Quantity
△a	O-ring	Soapy water	As required

◆ Inspection procedures ◆

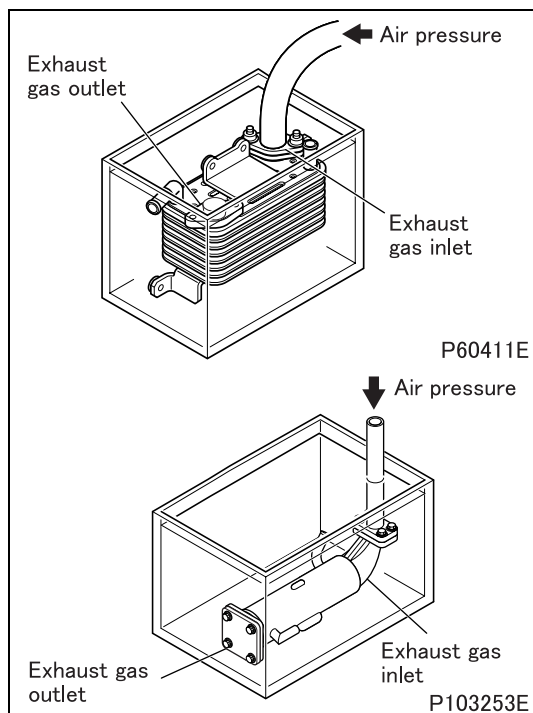

■ Inspection: Exhaust gas recirculation cooler

- Perform the following inspection. If any abnormality is found, replace the exhaust gas recirculation cooler.

(1) Exhaust gas passage side

- Fit a cover over the exhaust gas outlet of the exhaust gas recirculation cooler, and connect a hose to the exhaust gas inlet. Then, submerge the exhaust gas recirculation cooler in a container of water. Make sure the coolant passage is full of water.
- Apply specified air pressure through the hose. Check that air does not leak from any part of the exhaust gas recirculation cooler.

EXHAUST GAS RECIRCULATION SYSTEM

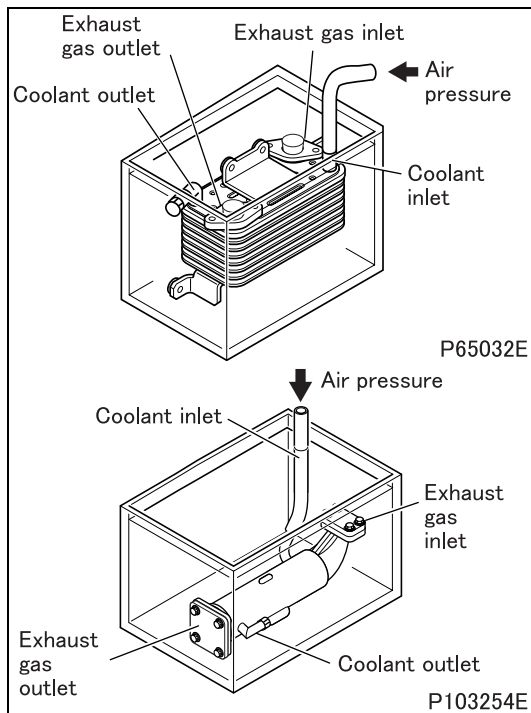

(2) Coolant passage side

- Fit covers over the exhaust gas recirculation cooler's exhaust gas inlet, exhaust gas outlet, and coolant outlet, and connect a hose to the coolant inlet. Then, submerge the exhaust gas recirculation cooler in a container of water.
- Apply air pressure of 196 kPa {28 psi, 2 kgf/cm²} through the hose. Check that air does not leak from any part of the exhaust gas recirculation cooler.
- If there is any abnormality, replace the exhaust gas recirculation cooler.

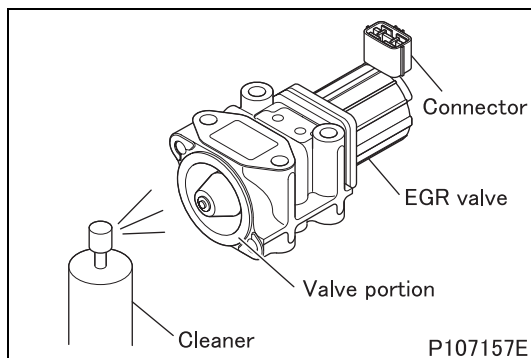

■ Inspection: Exhaust gas recirculation valve

- Check that the valve portion is free of soot, oily substance, etc.
- If not, clean the valve portion as follows.
- Spray a cleaner on the valve portion from 2 or 3 cm {0.79 or 1.18 in.} away.
Recommended cleaners:
Nonchlorinated solvent
- In 20 to 30 seconds after spraying, wipe the valve portion clear of the sprayed cleaner using a soft waste cloth the like.

CAUTION ⚠

- Be sure to wait for 20 to 30 seconds before wiping. It takes the cleaner that long to dissolve foreign matter.
- Do not spray a cleaner on the intake throttle connector directly. If it is sprayed on the connector, immediately wipe it off.

M E M O

CRANKCASE EMISSION CONTROL SYSTEM

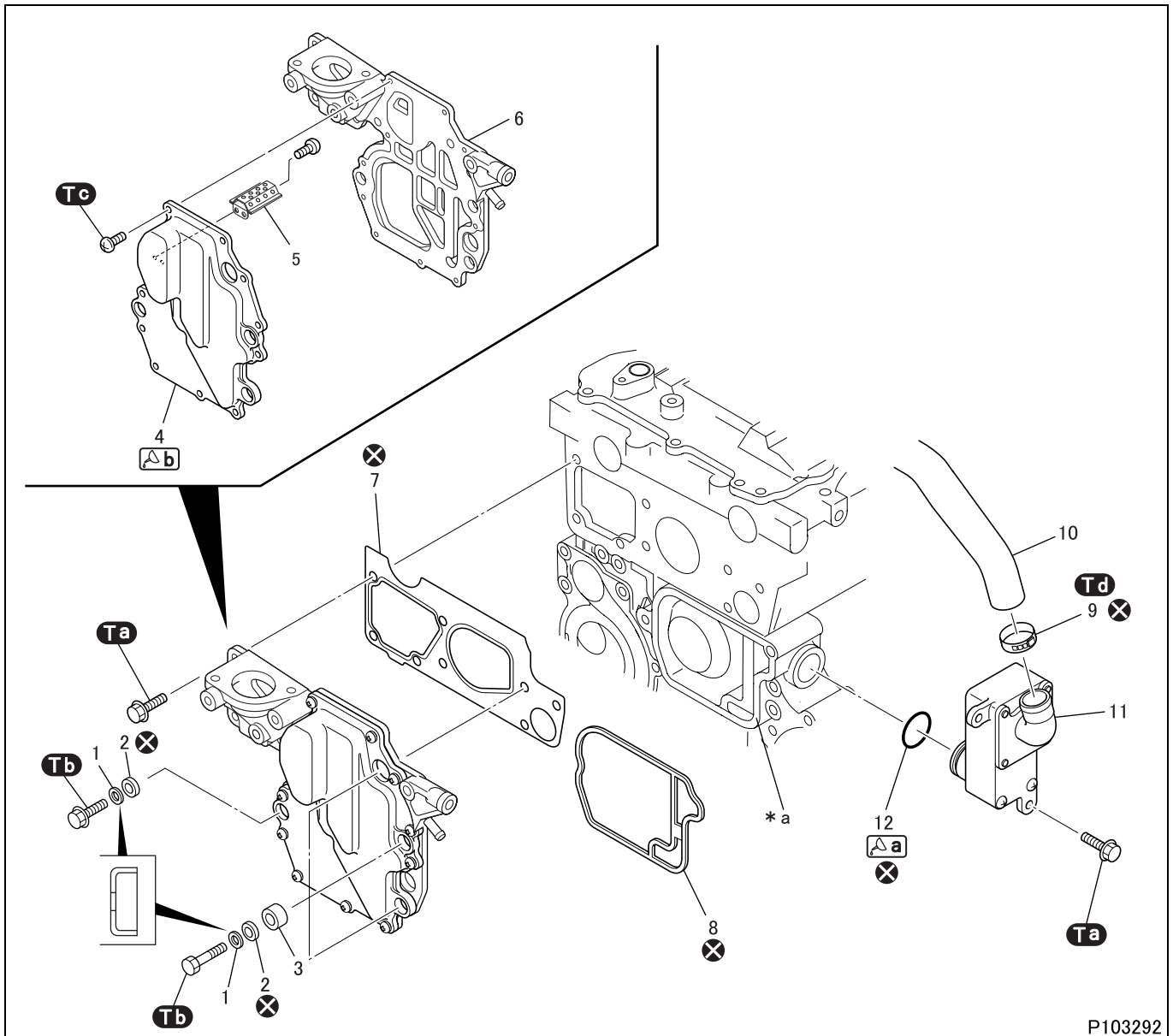

P103292

● Removal sequence

- | | | |
|--------------------|-------------------|-------------------------------------|
| 1 Washer | 7 Gasket | *a: Front case |
| 2 Rubber bushing | 8 Breather gasket | ⊗: Non-reusable parts |
| 3 Spacer | 9 Clamp | PCV: Positive crankcase ventilation |
| 4 Breather cover A | 10 PCV hose | |
| 5 Separator plate | 11 PCV valve | |
| 6 Breather cover B | 12 O-ring | |

● Installation sequence

Perform installation by following the removal sequence in reverse.

Tightening torque (Unit: N·m {ft.lbs, kgf·m})

Mark	Parts to be tightened	Tightening torque	Remarks
Ta	Bolt (mounting of breather cover A, B)	23.2 {17, 2.4}	-
	Bolt (mounting of PCV valve)		
Tb	Bolt (mounting of breather cover A, B)	9.8 {7.2, 1.0}	-
Tc	Screw (mounting of breather cover A)	2 to 3 {1.5 to 2.2, 0.2 to 0.3}	-
Td	Clamp	9 to 11 {6.6 to 8.1, 0.9 to 1.1}	-

Lubricant and/or sealant

Mark	Points of application	Specified lubricant and/or sealant	Quantity
a	O-ring	Engine oil	As required
b	Mating surface of breather cover A	ThreeBond 1216	As required

Special tools

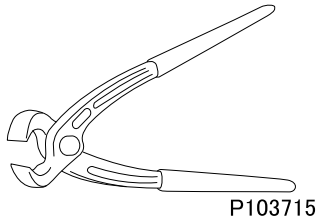
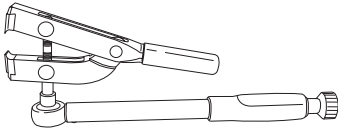
Mark	Tool name and shape	Part No.	Application
ca	Pincer 	MH063865	Removal of hose clamp
cb	Clamp installation tool 	MH063866	Installation of hose clamp

◆ Removal procedure ◆

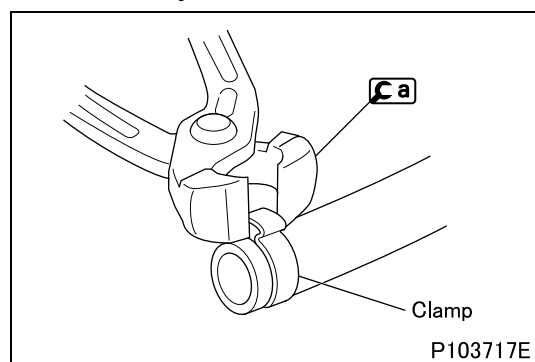

■ Removal: Clamp

- To remove the clamp, cut the clamp using **ca**.

CRANKCASE EMISSION CONTROL SYSTEM

◆ Installation procedures ◆

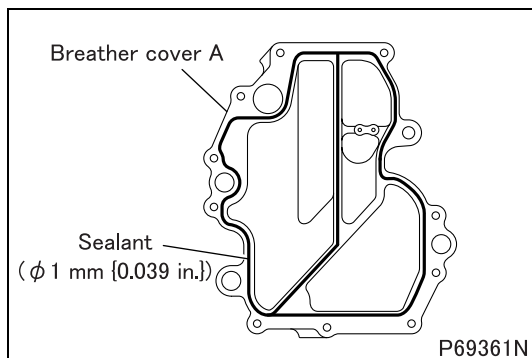

■ Installation: Breather cover A

- Clean the sealant application surfaces of each part.
- Apply a bead of sealant to the breather cover A evenly and without any breaks as shown in the illustration.
- Install the lower crankcase within three minutes of applying the sealant to the upper crankcase, being careful not to dislodge the sealant.

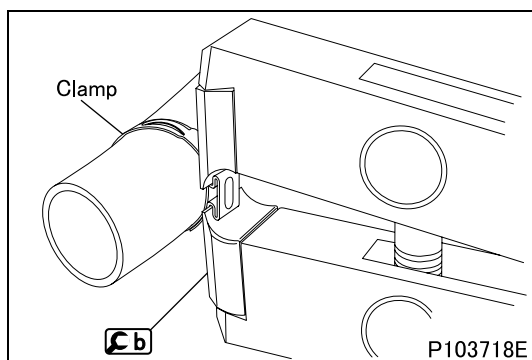

■ Installation: Clamp

- Pinch the projecting part of the clamp with **Cb** and tighten to the specified torque.