

INDEX

STRUCTURE AND OPERATION	
1. Wiper and Washer System	51-2
TROUBLESHOOTING	51-3
MIRROR	51-4
WIPER AND WASHER	51-6
FRONT COVER	51-8
GRILLE	51-10
EXTERIOR LIGHTING AND FRONT CORNER PANEL	51-14
FENDER	51-19
STEP	51-20
WHEEL WELL	51-21
WINDSHIELD AND CAB REAR WINDOW	51-22

STRUCTURE AND OPERATION

1. Wiper and Washer System

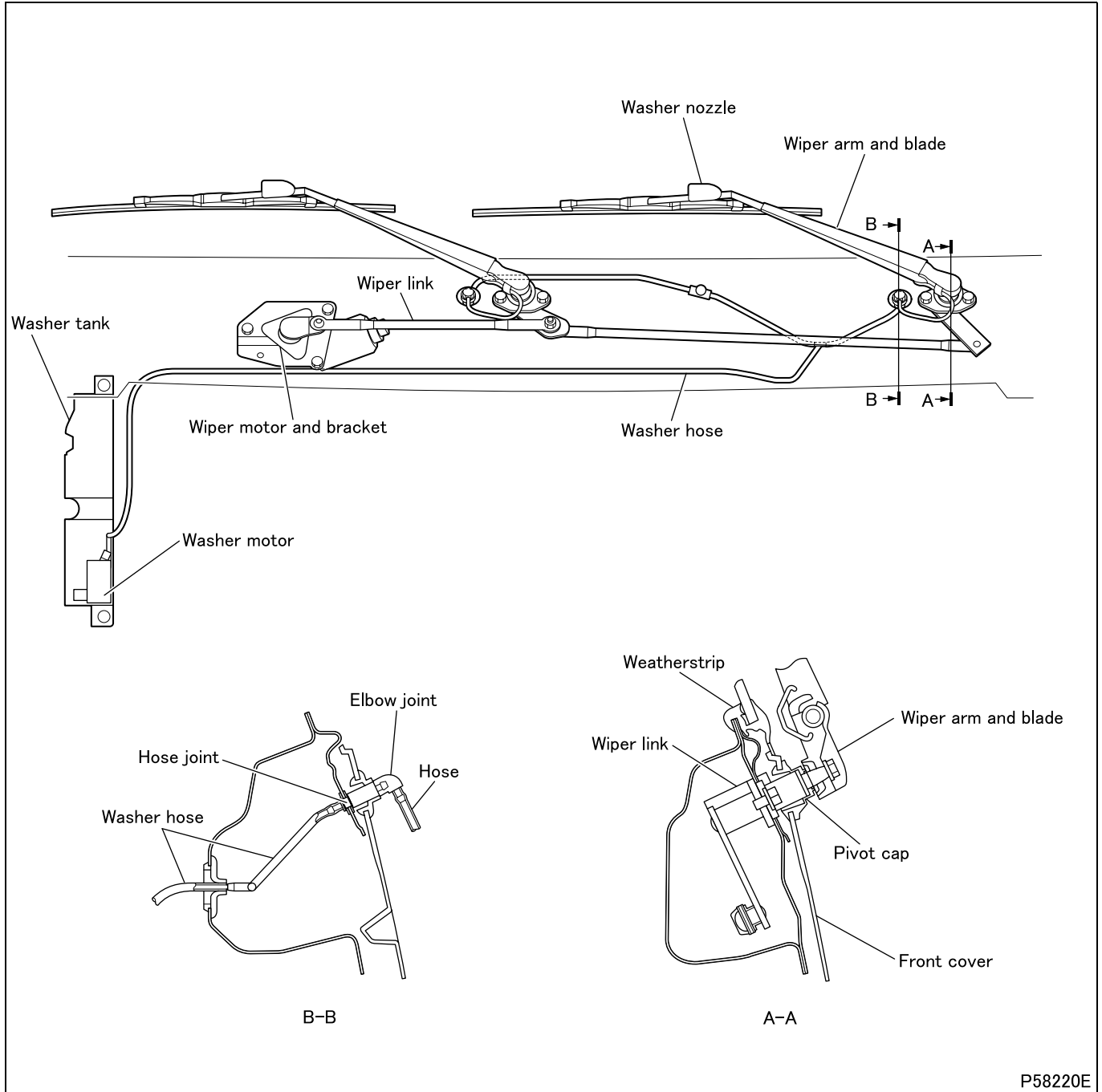

Wiper and washer

	Symptoms										Reference Gr
	Wiper fails to operate	Wiper fails to stop	Wiper fails to operate intermittently	Wiper blade stops at improper position	Wiper does not wipe well	Wiper emits noise during operation	Washer motor fails to operate	Washer injects insufficient amount of fluid	Washer fails to inject washer fluid	Wiper fails to operate in unison with washer	
Possible causes											
Wiper motor faulty	○	○		○		○					Gr54
Washer motor faulty						○	○	○			
Wiper and washer switch faulty	○	○	○			○			○		
MUTIC (control unit) faulty			○						○		
Wiper relay faulty	○					○					
Fuse/high current fuse blown	○					○					
Connector improperly connected, harness open-circuited, grounding improper	○		○			○		○	○		
Wiper motor crank arm out of position				○							
Wiper link and wiper arm improperly connected					○						
Wipe blade defective					○	○					
Wiper arm defective					○						
Washer hose twisted							○	○			
Washer hose improperly connected							○	○			
Washer nozzle clogged							○	○			
Washer fluid insufficient								○			

MIRROR

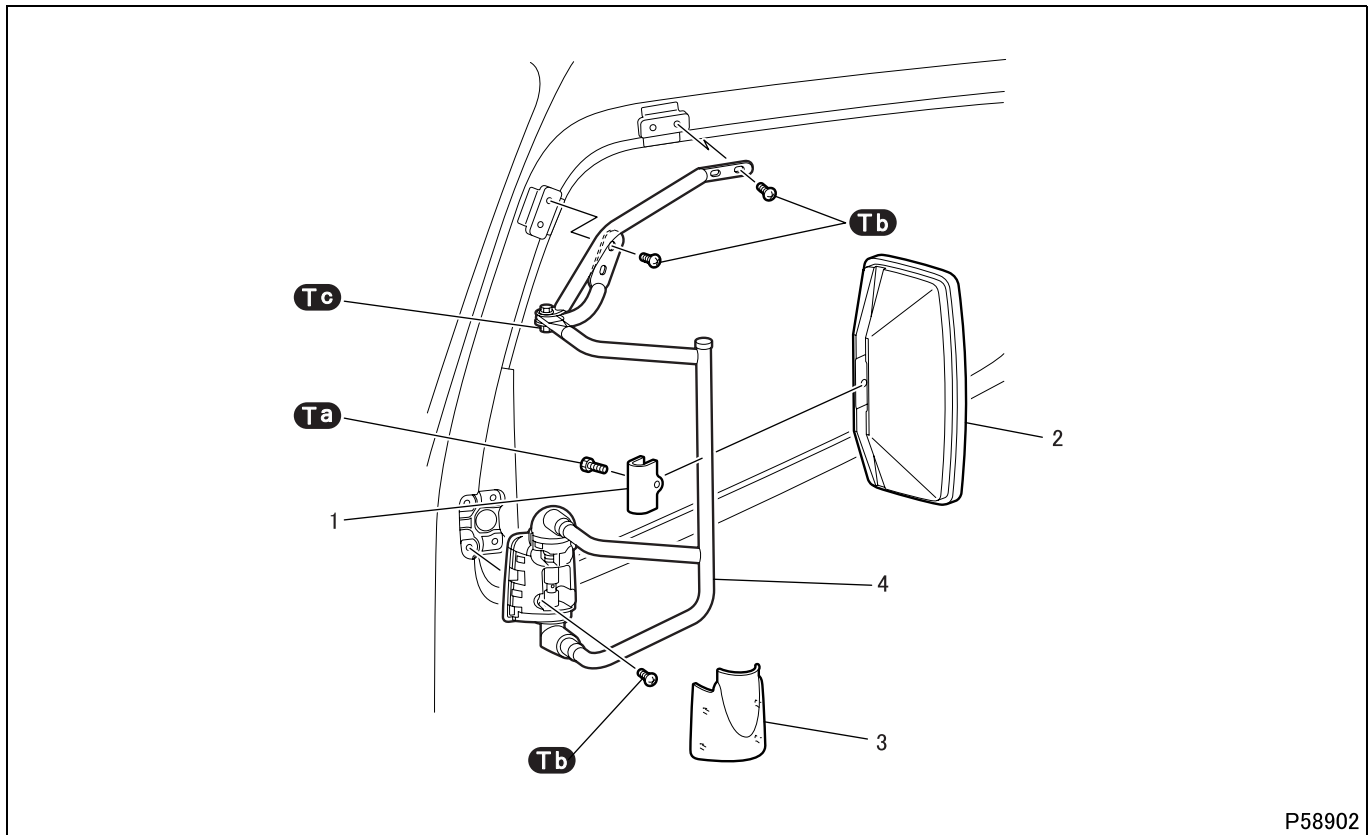

P58902

● Disassembly sequence

- | | |
|----------|---------------|
| 1 Clamp | 3 Cover |
| 2 Mirror | 4 Mirror stay |

● Assembly sequence

Follow the disassembly sequence in reverse.

Tightening torque (Unit: N·m {ft.lbs, kgf·m})

Mark	Parts to be tightened	Tightening torque	Remarks
Ta	Bolt (mirror mounting)	6.5 to 7.2 {4.8 to 5.3, 0.66 to 0.73}	—
Tb	Screw (mirror stay mounting)	9 to 14 {6.6 to 10, 0.9 to 1.4}	—
Tc	Nut (mirror stay fastening)	19 to 28 {14 to 21, 1.9 to 2.9}	—

◆ Removal procedure ◆

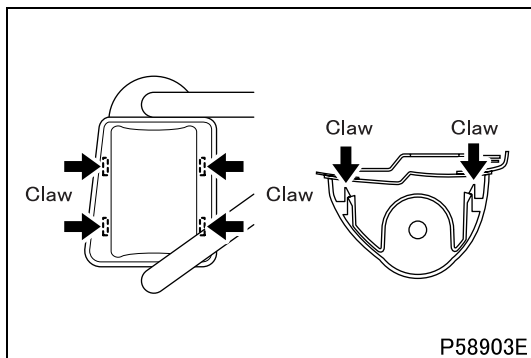

■ Removal: Cover

P58903E

◆ Installation procedure ◆

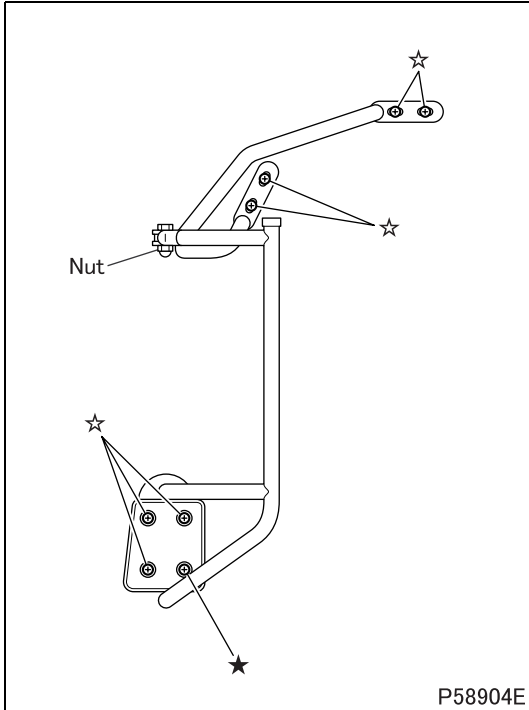

■ Installation: Mirror stay

- Install the one screw marked ☆ and adjust the position of the mirror stay.
- Install all the remaining seven screws marked ☆ to secure the mirror stay.
- Fasten the mirror stay nut to the specified torque.

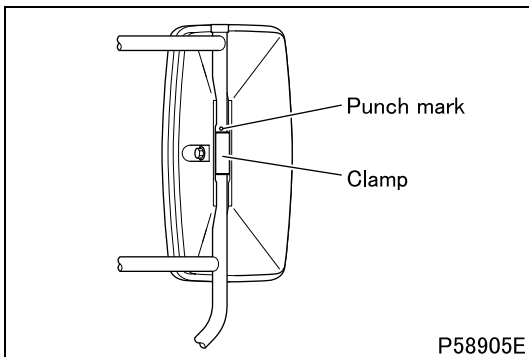

■ Installation: Mirror

- Adjust the height of the mirror by aligning the punch mark on the mirror stay with the clamp edge as shown in the illustration.

WIPER AND WASHER

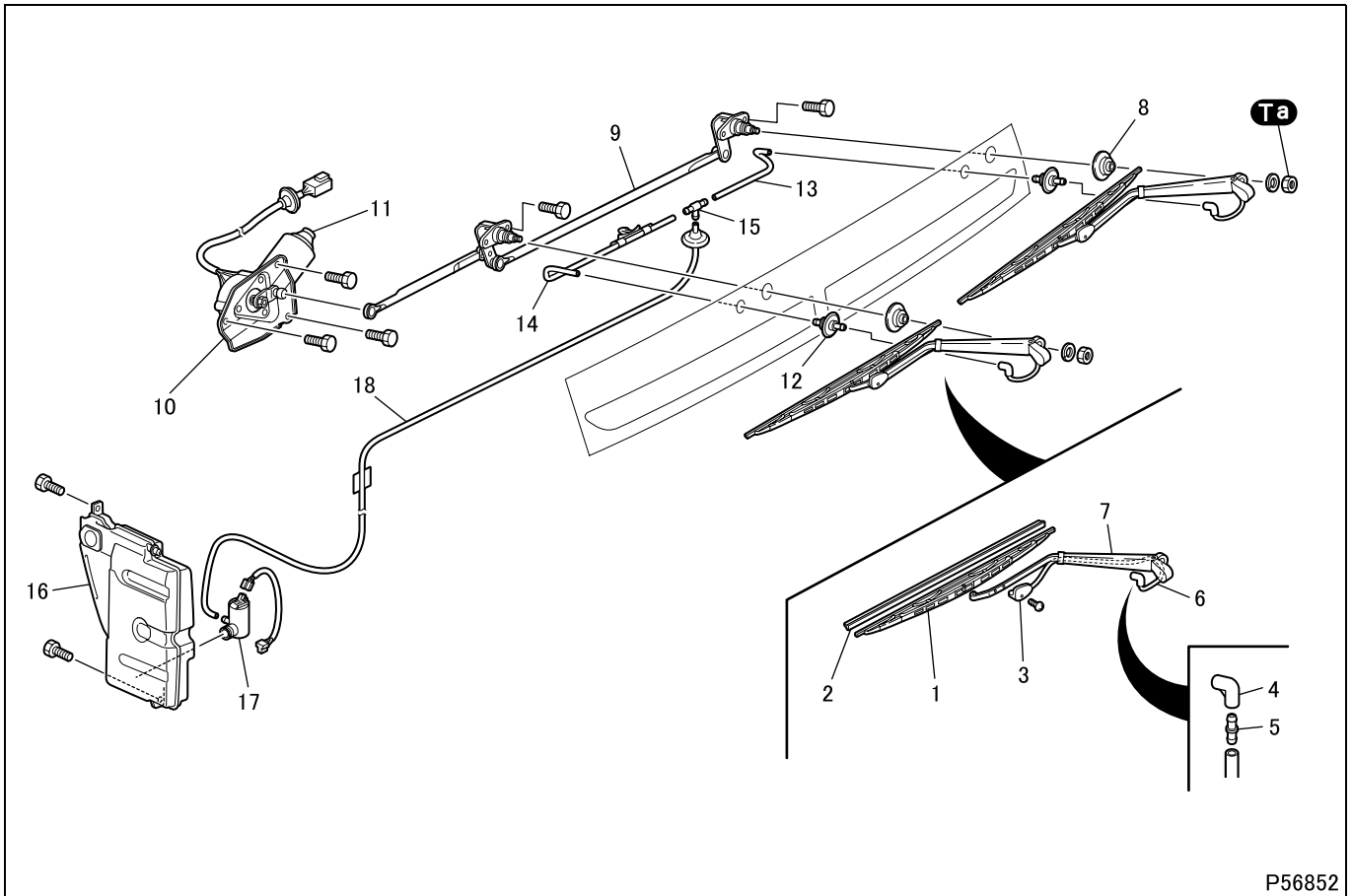

P56852

● Disassembly sequence

- | | |
|-----------------|------------------------|
| 1 Wiper blade | 10 Wiper motor bracket |
| 2 Blade rubber | 11 Wiper motor |
| 3 Washer nozzle | 12 Joint |
| 4 Elbow joint | 13 Washer hose |
| 5 Joint | 14 Washer hose |
| 6 Hose | 15 Joint |
| 7 Wiper arm | 16 Washer tank |
| 8 Pivot cap | 17 Washer motor |
| 9 Wiper link | 18 Washer hose |

NOTE

- Before disconnecting the connector to remove the wiper motor, pull out cab side harness enough, otherwise it will fall in the cab side and cannot be taken out without removing the instrument panel.

● Assembly sequence

Follow the disassembly sequence in reverse.

Service standards

Location	Maintenance item	Standard value	Limit	Remedy
7	Wiper arm force to press blade against windshield	$6.2 \pm 0.5 \text{ N}$ { $1.4 \pm 0.11 \text{ lbs,}$ $0.63 \pm 0.05 \text{ kgf}$ }	–	Replace

Tightening torque (Unit: N·m {ft.lbs, kgf·m})

Mark	Parts to be tightened	Tightening torque	Remarks
Ta	Nut (wiper arm and blade attaching)	11 to 16 {8.1 to 12, 1.1 to 1.6}	–

◆ Inspection procedure ◆

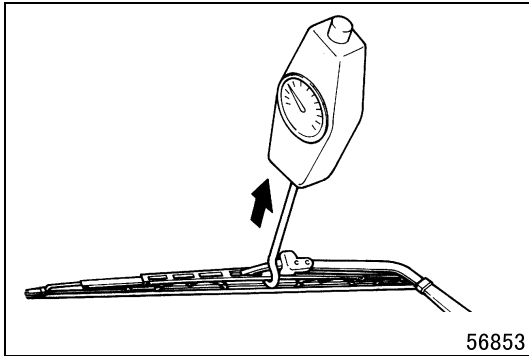

■ Inspection: Wiper arm

- Measure the wiper arm force to press the blade against the windshield.
- If the measurement deviates from the standard value, replace the wiper arm.

◆ Installation procedure ◆

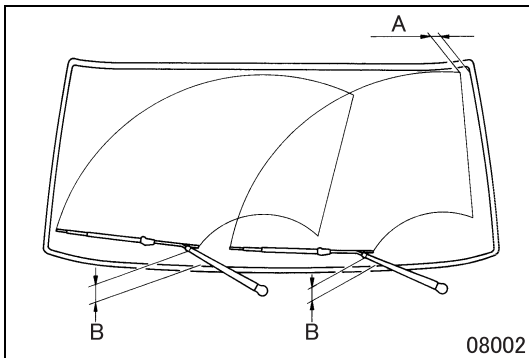

■ Installation: Wiper arm and blade

- Install the wiper arm and blade so that the blades come to the illustrated points as much as **A** and **B** apart from the edge of weatherstrip.
A: 50 mm {1.97 in.}
B: 59 ± 5 mm {2.3 ± 0.20 in.}

FRONT COVER

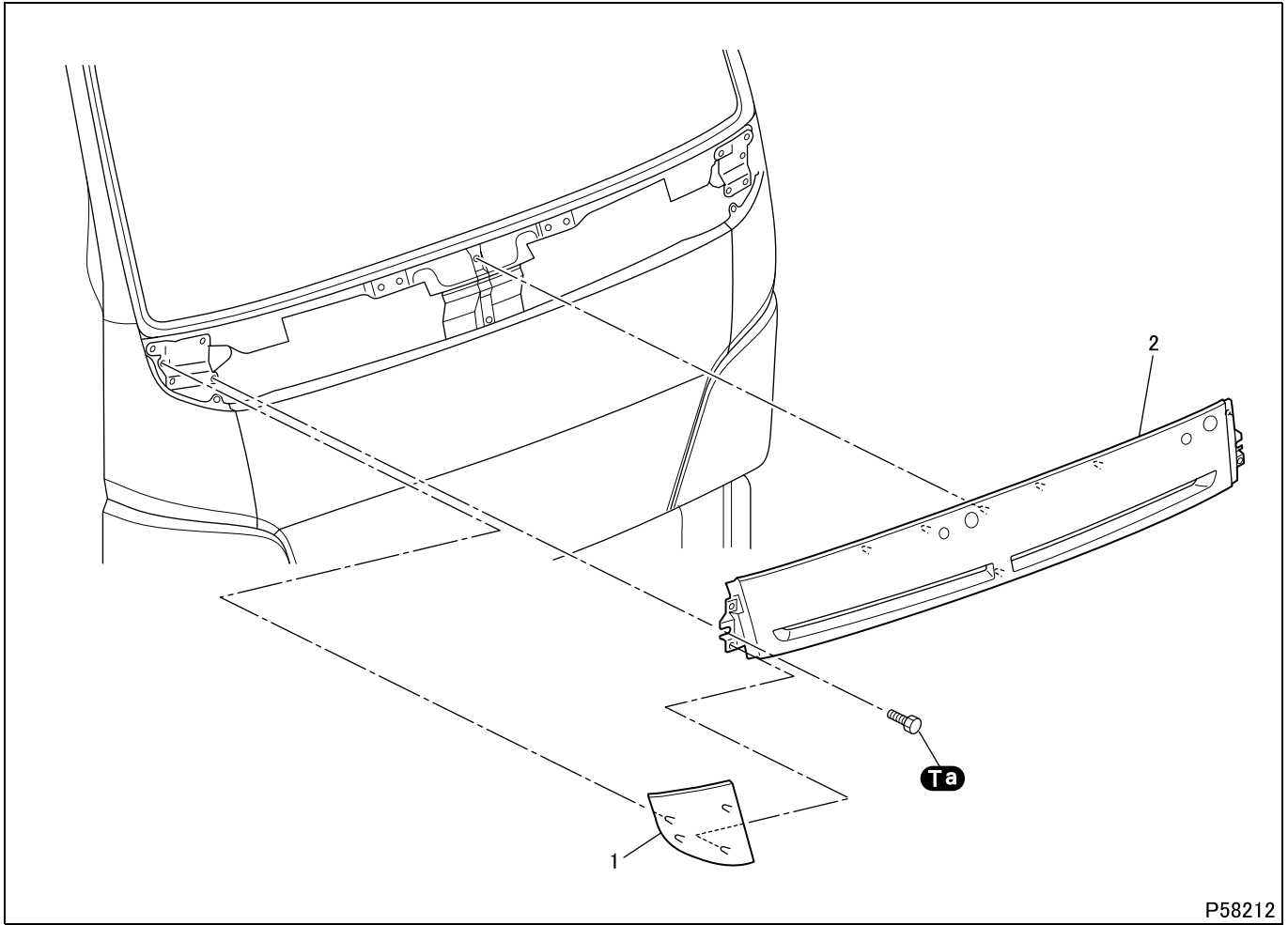

● Disassembly sequence

- 1 Front side cover
- 2 Front cover

● Assembly sequence

Follow the disassembly sequence in reverse.

Tightening torque (Unit: N·m {ft.lbs, kgf·m})

Mark	Parts to be tightened	Tightening torque	Remarks
Ta	Bolt (front cover attaching)	9 to 14 {6.6 to 10, 0.9 to 1.4}	—

◆ Removal procedure ◆

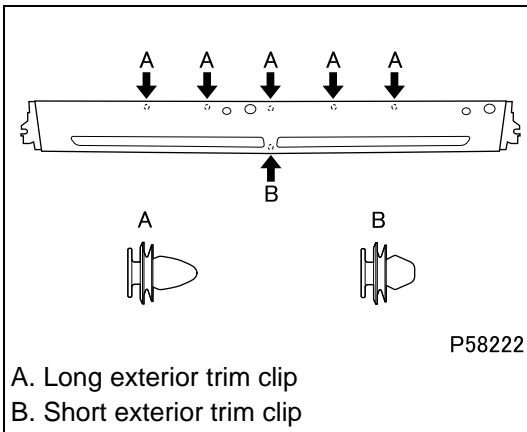
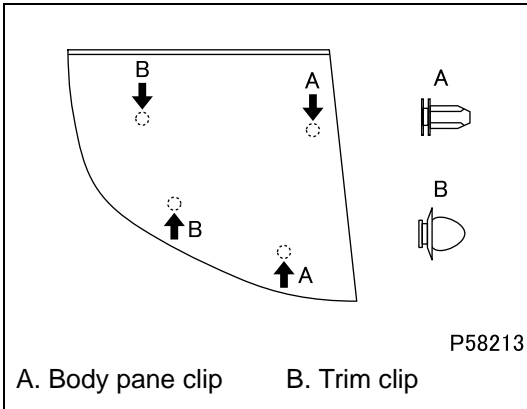

◆ Removal procedure ◆

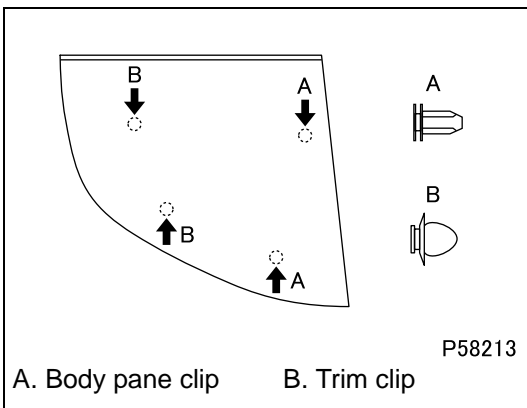
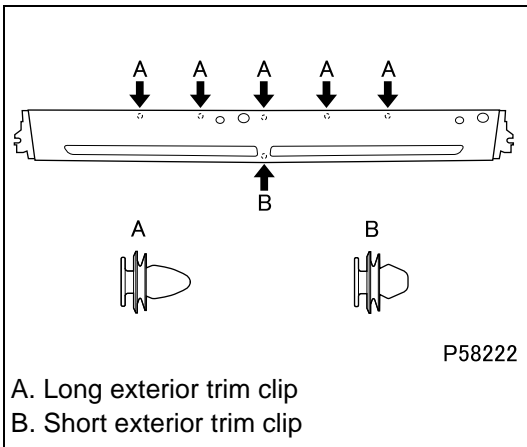

■ Removal: Front side cover

- 1 Remove the two body panel clips on the inboard edge of the front side cover.
- 2 Remove the two trim clips on the outboard edge of the front side cover.

■ Removal: Front cover

- 1 Remove the two front cover mounting capscrews, one on each end of the front cover.
- 2 Remove the five long exterior trim clips on the upper edge of the front cover.
- 3 Remove the short exterior trim clip on the lower edge of the front cover.

■ Installation: Front cover

- 1 Install the five long exterior trim clips on the upper edge of the front cover.
- 2 Install the short exterior trim clip on the lower edge of the front cover.
- 3 Install the two front cover mounting capscrews and tighten them 9 to 14 N·m (7 to 10 lbf·ft).

■ Installation: Front side cover

- 1 Install the two body panel clips on the inboard edge of the front side cover.
- 2 Install the two trim clips on the outboard edge of the front side cover.

GRILLE

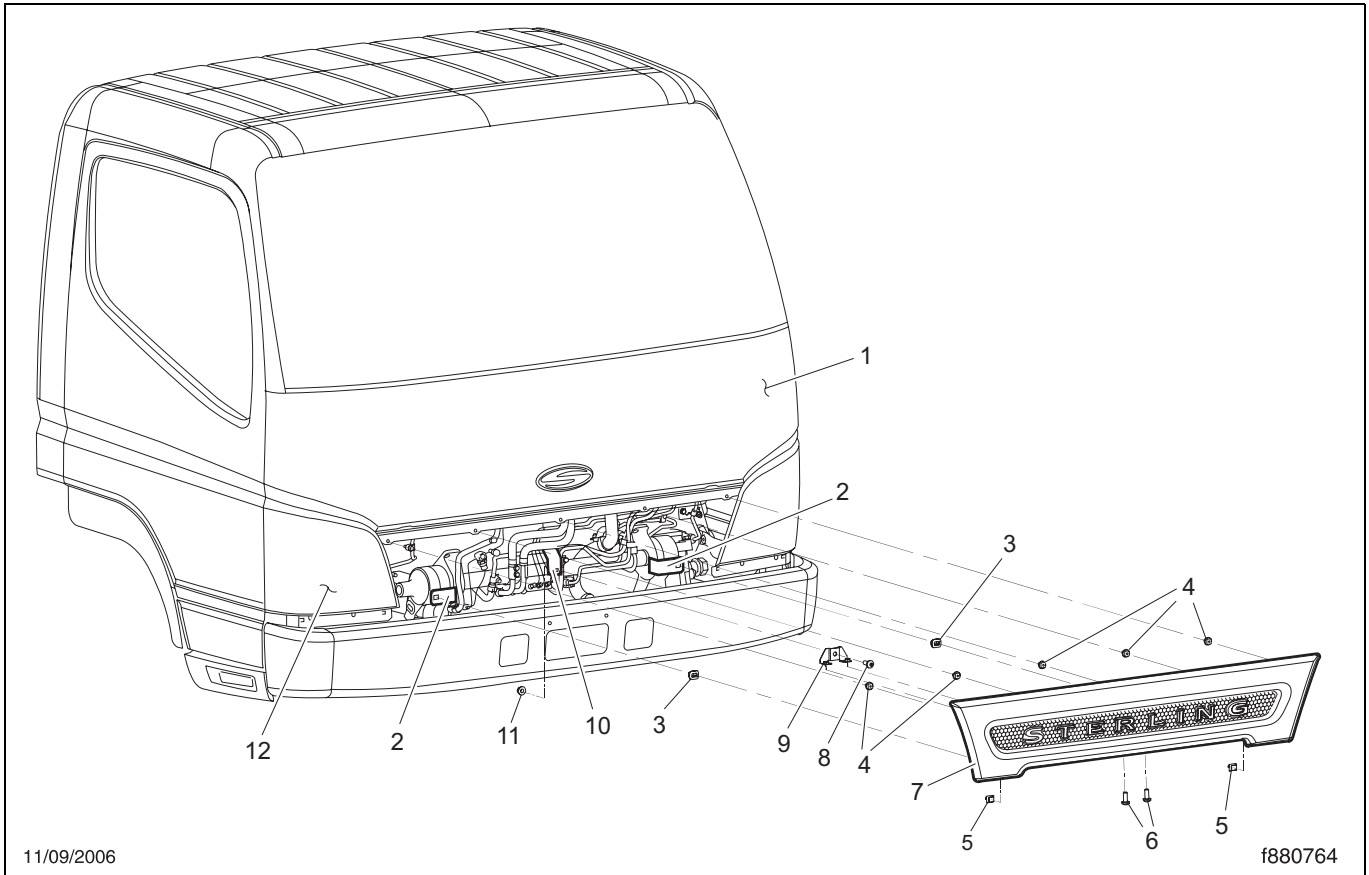

● Grille and front corner panel components

- | | |
|---------------------------------------|---|
| 1 Cab | 7 Grille |
| 2 Grille side bracket | 8 Hanger bracket mounting screw (M8 pan-head) |
| 3 Pin clip retainer (grommet) | 9 Grille hanger bracket |
| 4 Bird-cage clip | 10 Grille center bracket |
| 5 Pin clip | 11 Flange nut |
| 6 Grille mounting screw (M8 pan-head) | 12 Exterior lighting and front corner panel |

Tightening torque (Unit: N·m {ft.lbs})

Mark	Parts to be tightened	Tightening torque	Remarks
6	Grille mounting screw	18 (13)	M8 Pan-head
9	Flange nut		—

◆ Removal procedure ◆

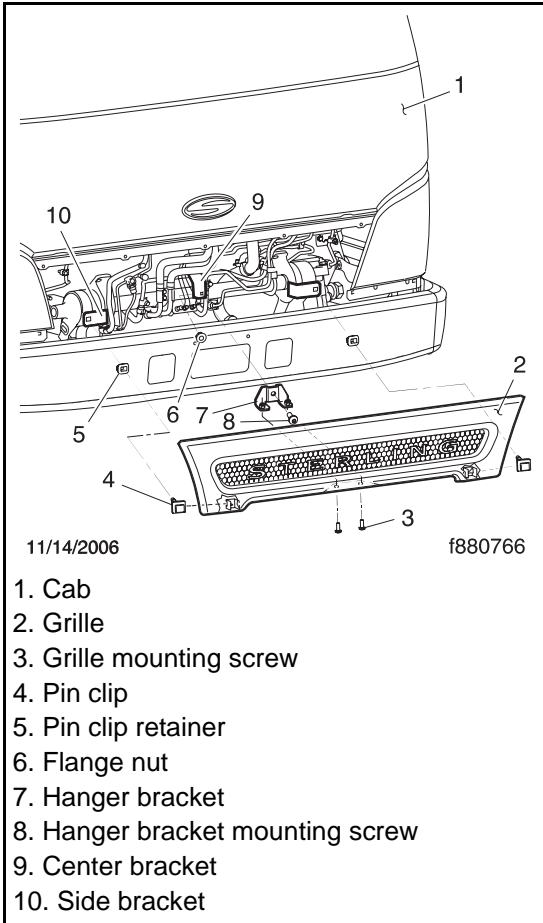

■ Removal: Grille fasteners

- 1 Remove the two M8 grille mounting screws that attach the lower flange of the grille to the grille hanger bracket.

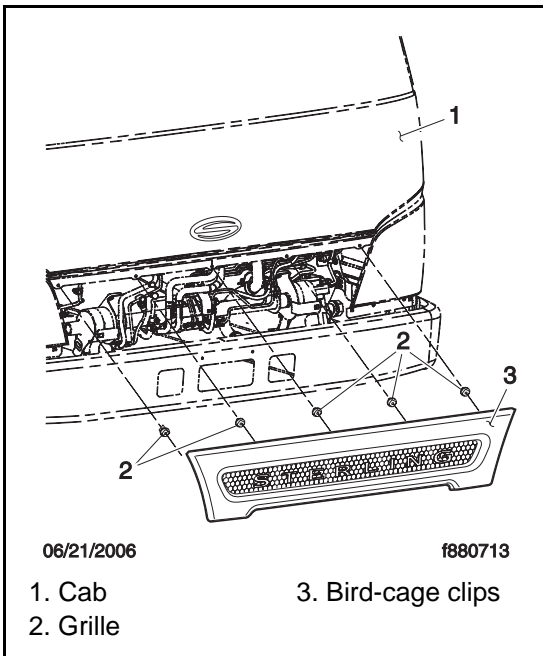

■ Removal: Grille

- 1 Release the five bird-cage clips at the top of the grille and the two plastic pin clips from the pin clip receptacles at the bottom of the grille by gently pulling outward on the grille.
- 2 Remove the grille from the cab.
- 3 If it is also necessary to remove the grille hanger bracket, remove the M8 hanger bracket mounting screw and flange nut that attach the hanger bracket to the center bracket.

GRILLE

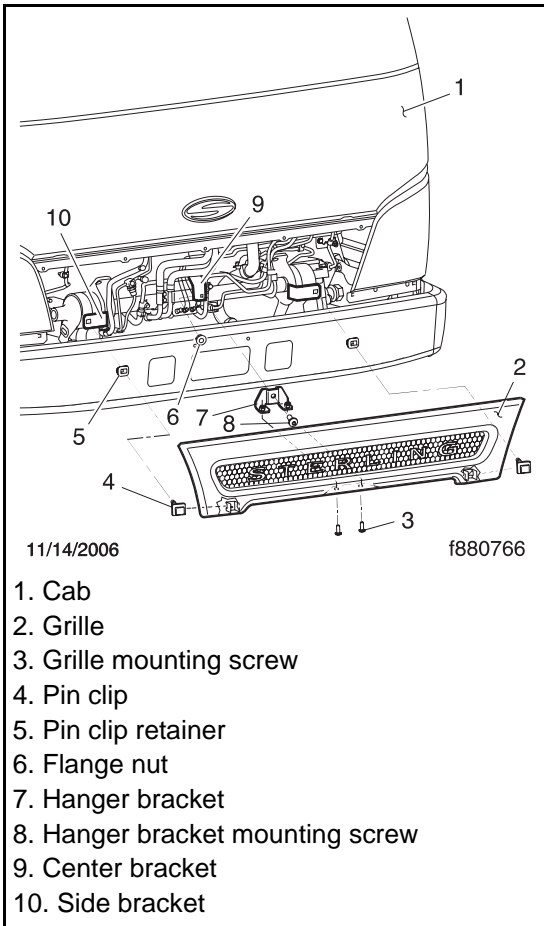

1. Cab
2. Grille
3. Grille mounting screw
4. Pin clip
5. Pin clip retainer
6. Flange nut
7. Hanger bracket
8. Hanger bracket mounting screw
9. Center bracket
10. Side bracket

■ Installation: Grille fasteners

- 1 If the grille hanger bracket was removed, install the M8 hanger bracket mounting screw and flange nut that attach the hanger bracket to the center bracket. Tighten the nut 18 N·m (13 lbf·ft).
- 2 Position the lower flange of the grille on the grille hanger bracket.

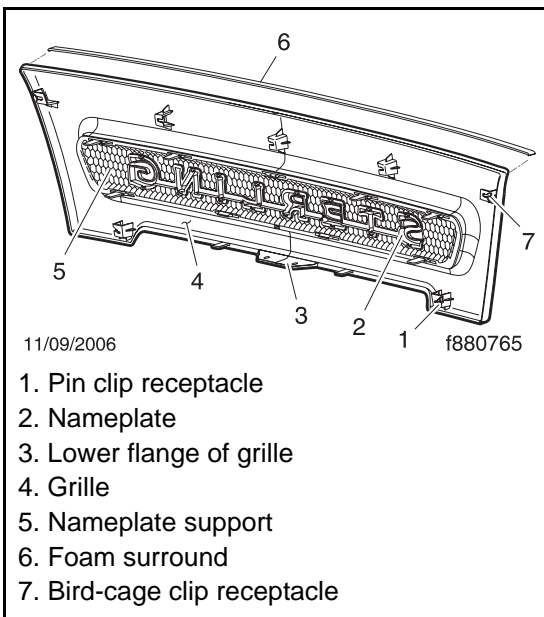

1. Pin clip receptacle
2. Nameplate
3. Lower flange of grille
4. Grille
5. Nameplate support
6. Foam surround
7. Bird-cage clip receptacle

■ Installation: Grille

- 1 Check the foam surround at the top of the grille and remove any portions hanging down.
- 2 Install the five bird-cage clips at the top of the grille. Install the two plastic pin clips into the receptacles at the base of the grille.
- 3 Push in on the grille and make sure that it is flush with the front cab panel and all fasteners are snug.
- 4 Install the two M8 machine screws into the weld nuts on the grille hanger bracket and tighten them 18 N·m (13 lbf·ft).

M E M O

EXTERIOR LIGHTING AND FRONT CORNER PANEL

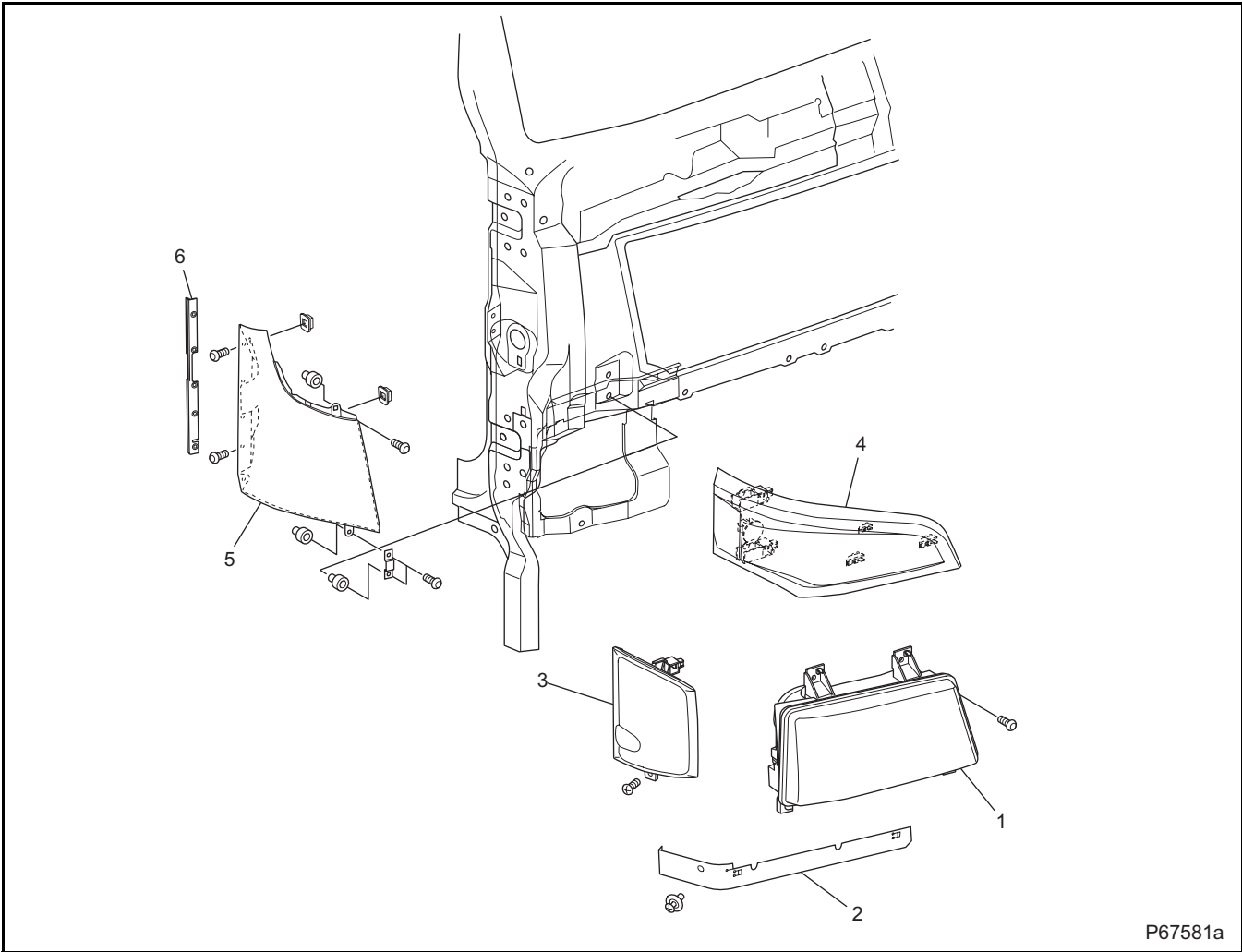

P67581a

Headlight, turn signal lens, and reflector

- 1 Headlight
- 2 Headlight bezel
- 3 Reflector
- 4 Front and side turn signal lens
- 5 front corner panel
- 6 Door opening seal

CAUTION

- Do not attempt to forcibly remove the reflector, front and side turn signal lens, and headlight. The mounting fasteners could be damaged.

◆ Removal procedure ◆

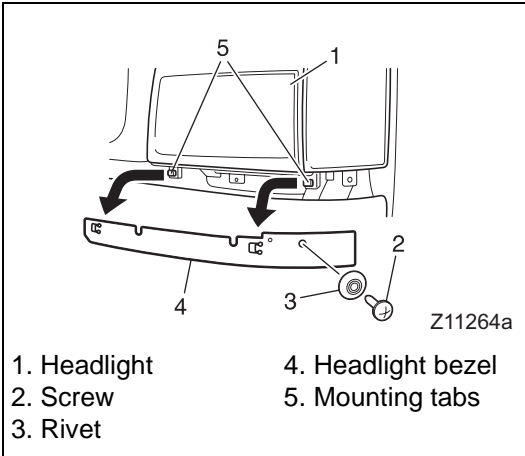

■ Removal: Headlight bezel

- 1 Remove the screw and rivet. Slide the headlight bezel side-ways to release it.
- 2 Move the headlight bezel from underneath the headlight toward the centerline of the vehicle to release it from the mounting tabs.

CAUTION ⚠

- When removing the headlight bezel, do not use excessive force. The mounting tabs could break.

NOTE

The keeper screws are designed to remain in the vehicle. They are not supposed to be removed.

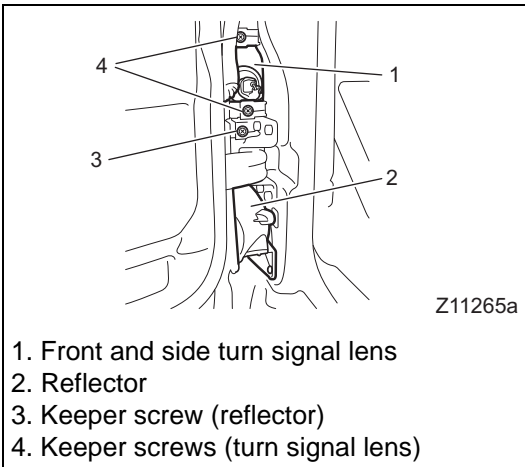

■ Removal: Front and side turn signal lens

- 1 Open the door. Loosen the two keeper screws behind the front and side turn signal lens until they spin freely.
- 2 Pull out the keeper screws until they are fully extended.
- 3 Close the door. Pull the turn signal lens away from the vehicle as shown in the illustration.
- 4 When the turn signal lens is free, remove the connector.

CAUTION ⚠

- When removing the front and side turn signal lens, do not pull it forward (toward the front of the vehicle). This could break the mounting tabs.
- Do not open the door with the front and side turn signal lens moved outward (but not completely removed). The door could hit the lens and damage it.

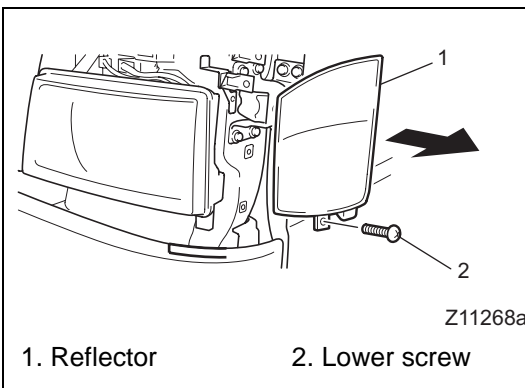

■ Removal: Reflector

- 1 Open the door. Loosen the keeper screw behind the reflector until it spins freely.
- 2 Pull out the keeper screw until it is fully extended.
- 3 Remove the lower screw (at the bottom of the reflector) and pull the reflector away from the vehicle, as shown in the illustration.

EXTERIOR LIGHTING AND FRONT CORNER PANEL

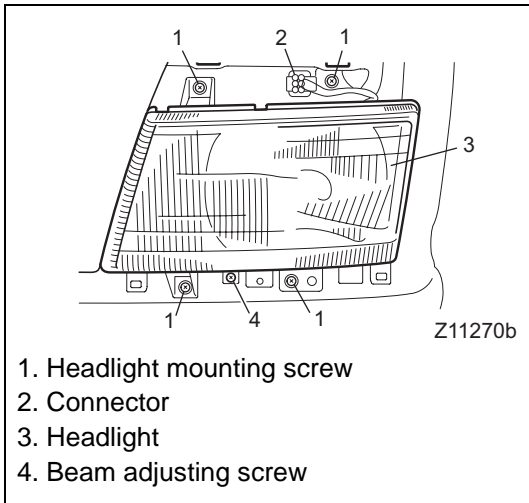

1. Headlight mounting screw
2. Connector
3. Headlight
4. Beam adjusting screw

■ Removal: Headlight

CAUTION ⚠

- Do not turn the beam adjusting screw. This would change the beam setting and could cause an injury accident.

- 1 Remove the headlight mounting screws and connector.
- 2 Raise the headlight slightly to remove the tabs from the slots. Then pull it out towards you.

CAUTION ⚠

- When setting down the removed headlight, place it on a soft cloth to avoid scratching the lens.

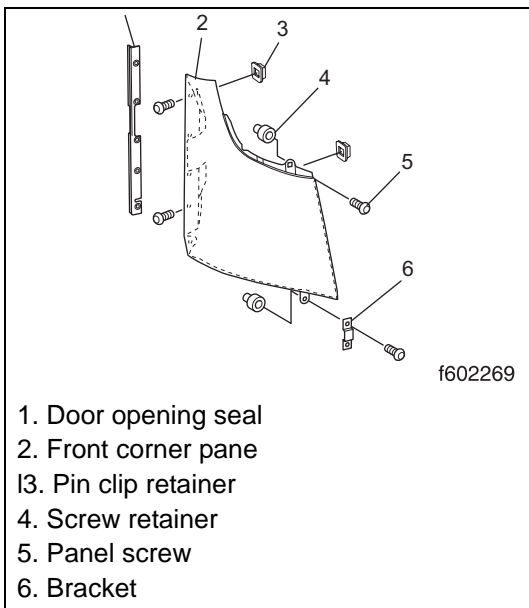

1. Door opening seal
2. Front corner pane
3. Pin clip retainer
4. Screw retainer
5. Panel screw
6. Bracket

■ Removal: Front corner panel

- 1 Open the door. Remove the two screws securing the front corner panel from behind.
- 2 Close the door. Remove the three screws securing the front corner panel from the front.
- 3 Remove the front corner panel.

NOTE

Do not remove the door opening seal unless absolutely necessary.

◆ Installation procedure ◆

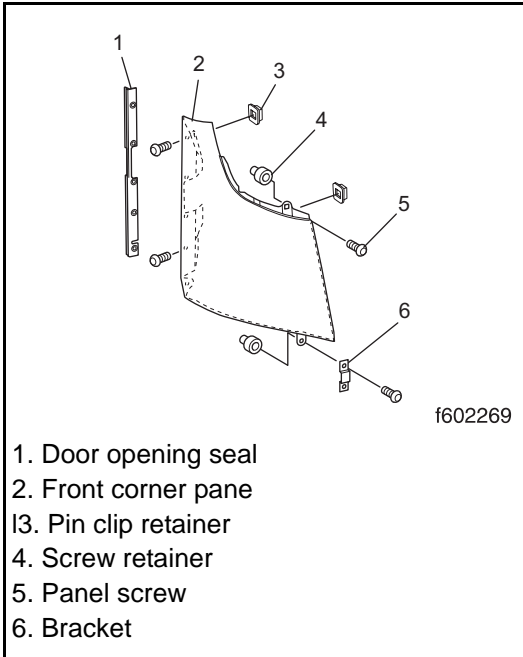

1. Door opening seal
2. Front corner pane
3. Pin clip retainer
4. Screw retainer
5. Panel screw
6. Bracket

■ Installation: Front corner panel

- 1 Position the front corner panel on the cab.
- 2 Install the screws, as removed.

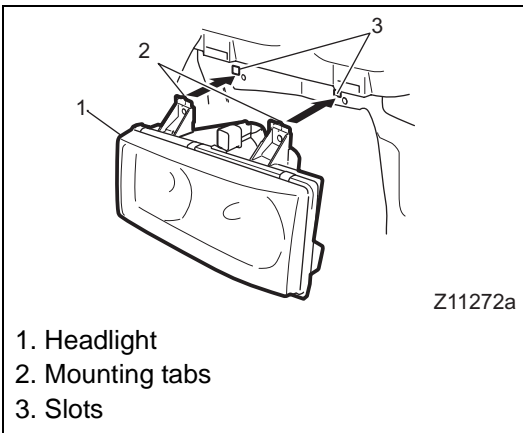

1. Headlight
2. Mounting tabs
3. Slots

■ Installation: Headlamp

- 1 Insert the tabs on the headlight into the slots, and position the headlight properly.
- 2 Install the headlight bolts and connector, as removed.

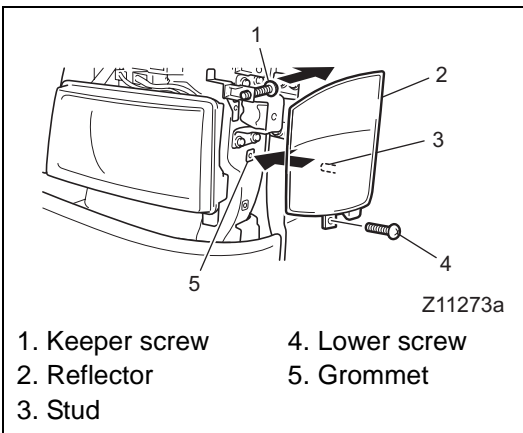

1. Keeper screw
2. Reflector
3. Stud
4. Lower screw
5. Grommet

■ Installation: Reflector

- 1 Pull out the reflector keeper screw until it is fully extended.
- 2 Insert the stud on the reflector into the grommet.

CAUTION ⚠

- Do not overtighten the lower screw. This could damage the mounting.

- 3 Open the door. Tighten the lower screw until firm.

EXTERIOR LIGHTING AND FRONT CORNER PANEL

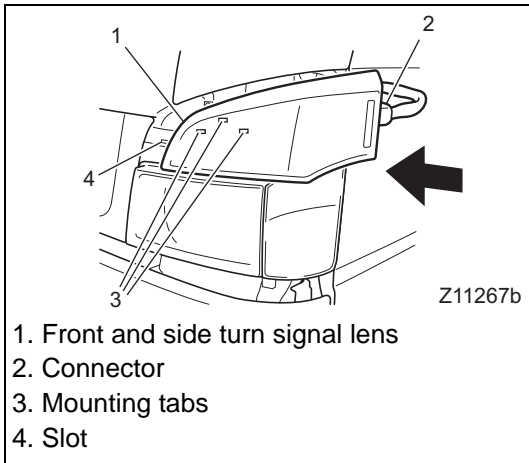

■ Installation: Front and side turn signal lens

- 1 Install the connector on the front and side turn signal lens.
- 2 Pull out the two turn signal keeper screws until they are fully extended.
- 3 Align each mounting tab with its slot.
- 4 Press the turn signal lens inward, toward the centerline of the vehicle.

CAUTION

- Press the front and side turn signal lens fully in toward the centerline of the vehicle. If the lens was not pressed fully into place and you opened the door, the door could hit the lens and damage it.
- Do not overtighten the keeper screws. This could damage the mounting.

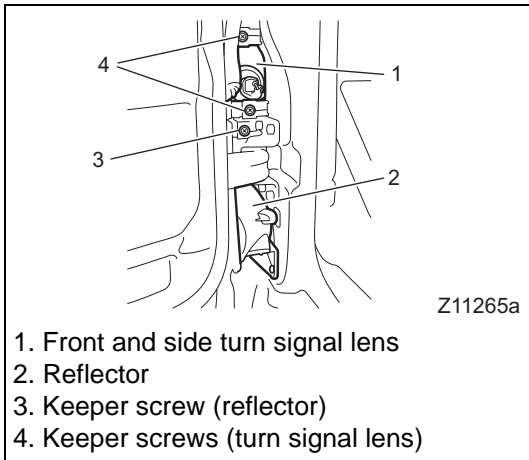

- 5 Open the door, and secure the turn signal lamp by tightening screws from behind.

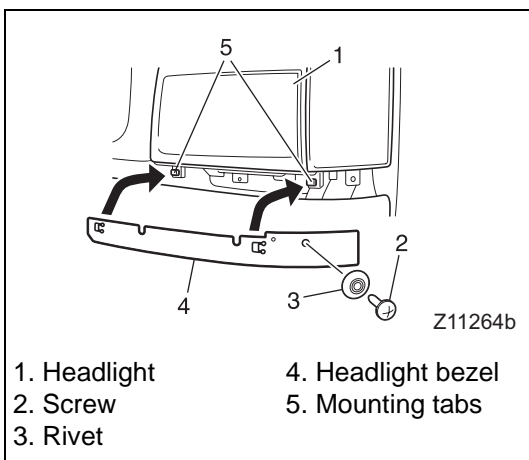

■ Installation: Headlight bezel

- 1 Fit the headlight bezel under the headlight and onto the tabs by moving it toward the outside of the vehicle.
- 2 Install the rivet and then press in the screw.

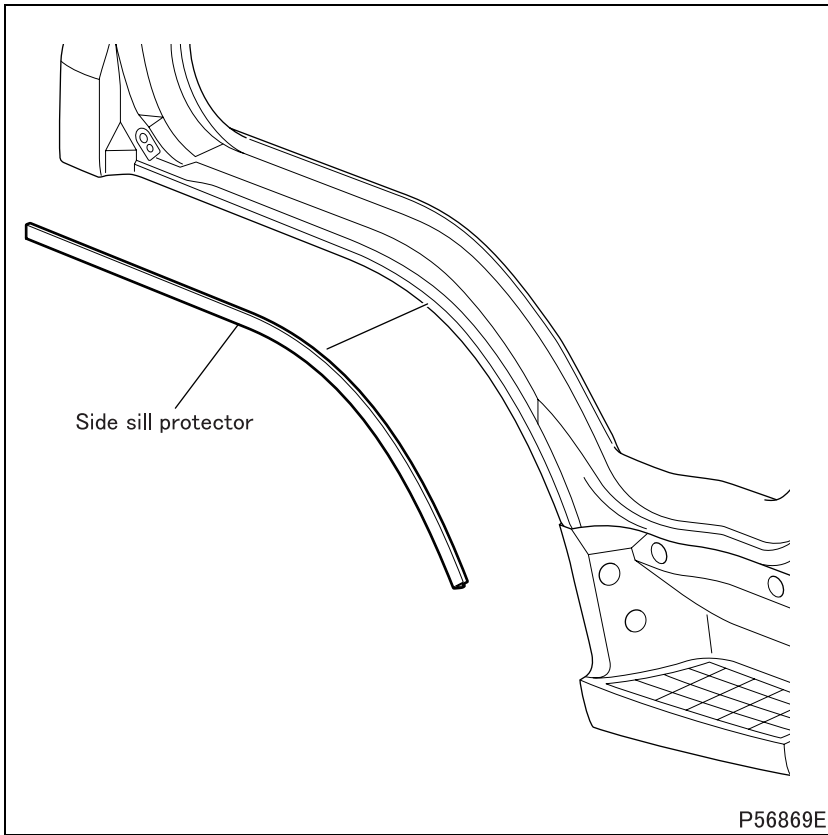

NOTE

- For details on removal and installation of the fender, refer to Gr43.
- Attach the side sill protector using double-coated adhesive tape.

STEP

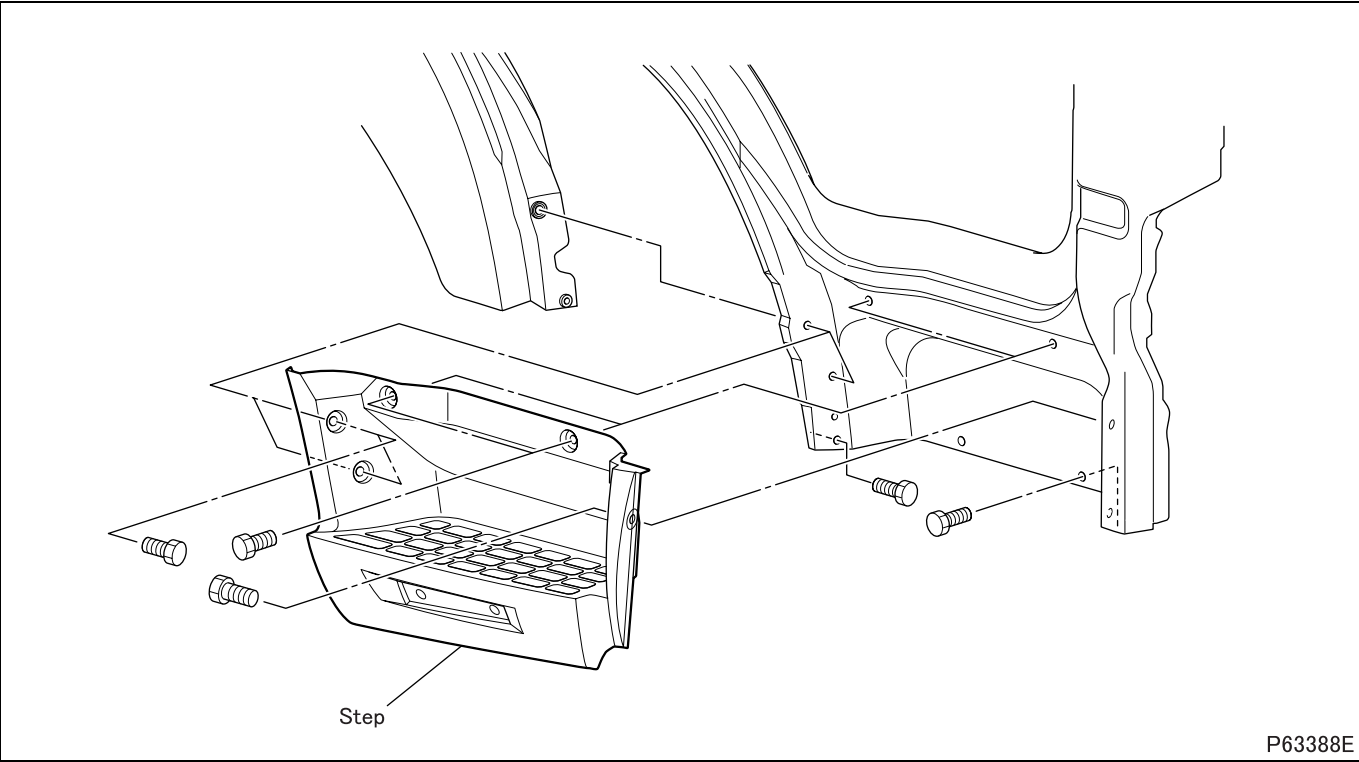

P63388E

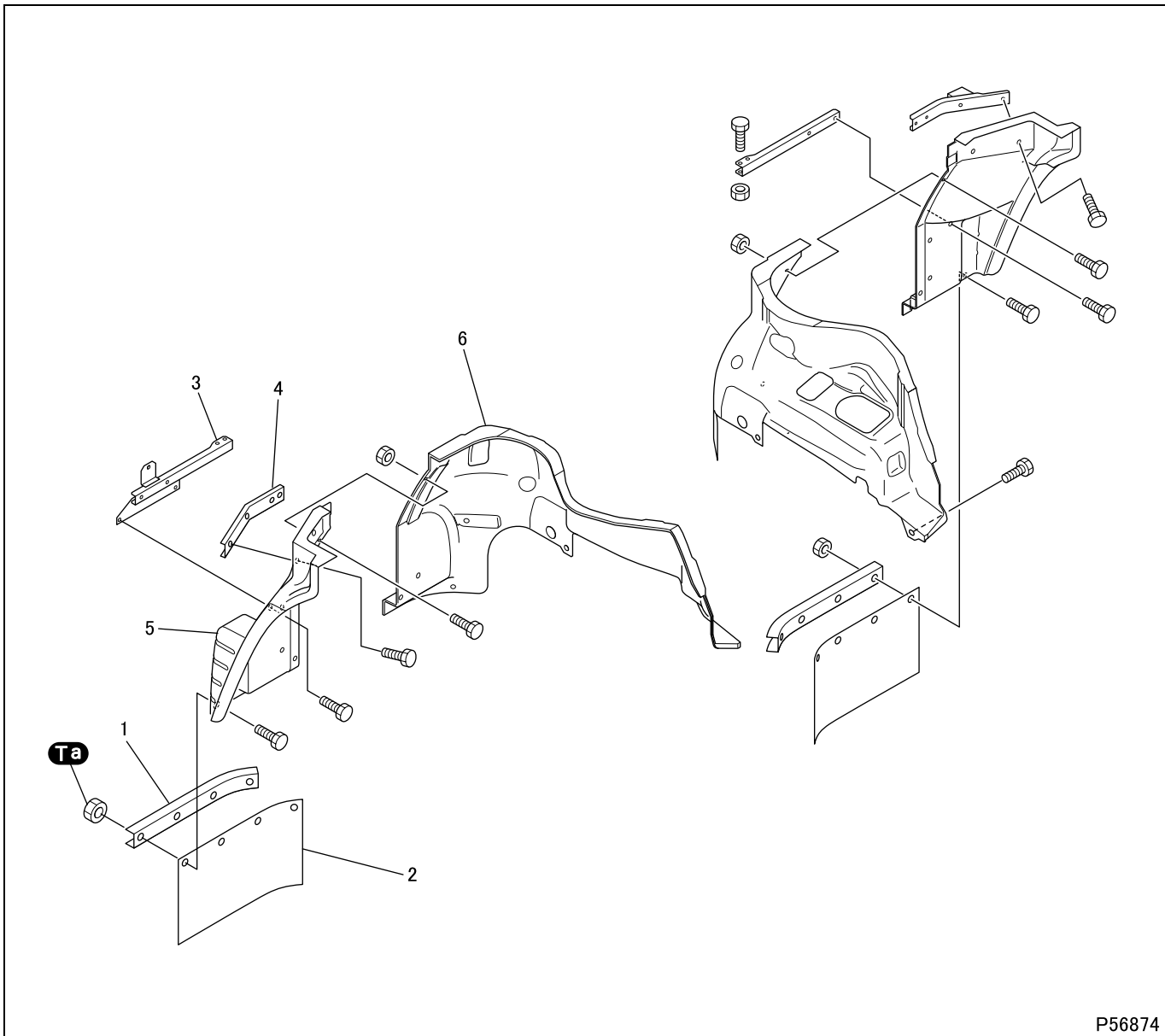

● Removal sequence

- | | |
|---------------------------|---------------------------|
| 1 Apron support | 4 Mud guard upper support |
| 2 Mud guard apron | 5 Mud under guard |
| 3 Mud guard lower support | 6 Lower shield panel |

● Installation sequence

Follow the removal sequence in reverse.

Tightening torque (Unit: N·m {ft.lbs, kgf·m})

Mark	Parts to be tightened	Tightening torque	Remarks
Ta	Nut (attaching apron support to mud guard apron)	3.9 to 5.9 {2.9 to 4.4, 0.4 to 0.6}	–

WINDSHIELD AND CAB REAR WINDOW

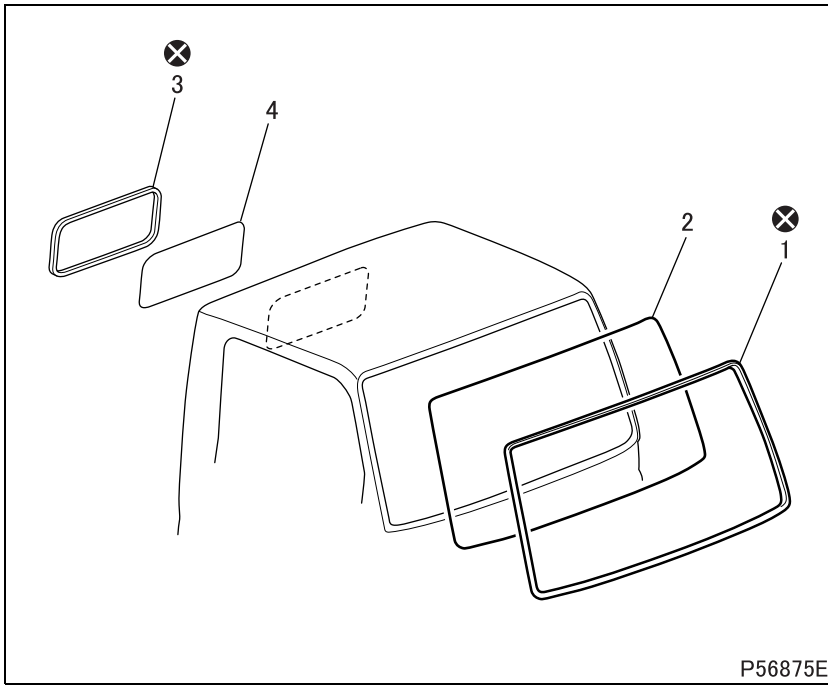

● Removal sequence

- 1 Windshield weatherstrip
- 2 Windshield glass
- 3 Rear window weatherstrip
- 4 Rear window glass

⊗: Non-reusable parts

● Installation sequence

Follow the removal sequence in reverse.

◆ Removal procedure ◆

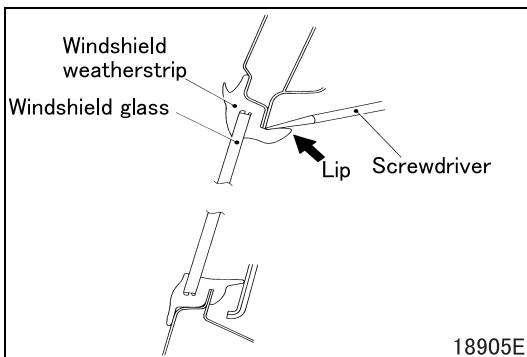

■ Removal: Windshield weatherstrip and windshield glass

- While prying up the lip of the weatherstrip with the tip of a screwdriver, push the windshield glass out from inside the cab.

● Installation procedure

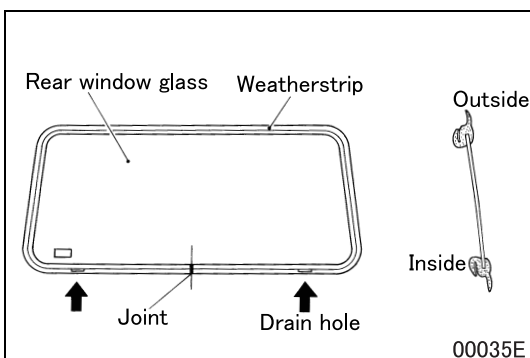

■ Installation: Rear window weatherstrip and rear window glass

- Fit the rear window weatherstrip round the rear window glass so that the joint of weatherstrip comes at the bottom center of the glass.
- Except for the point mentioned above, install the rear window glass in the same manner as the windshield glass.

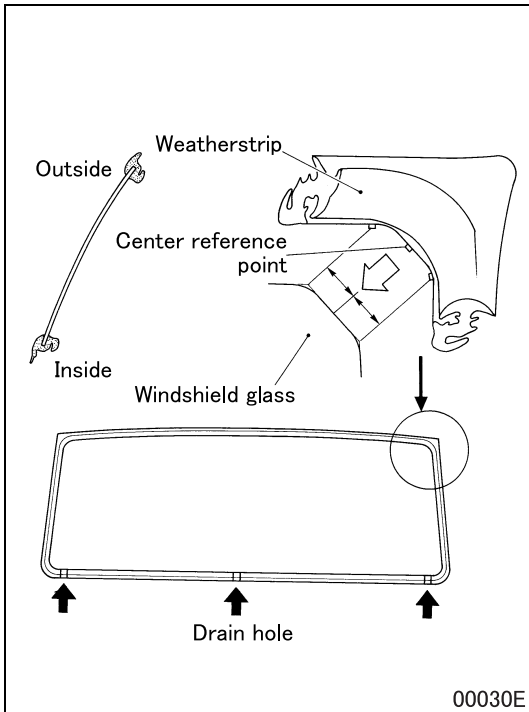

■ Installation: Windshield weatherstrip and windshield glass

- Install the weatherstrip with its center reference point aligned with the center of the cut at each corner of the glass.

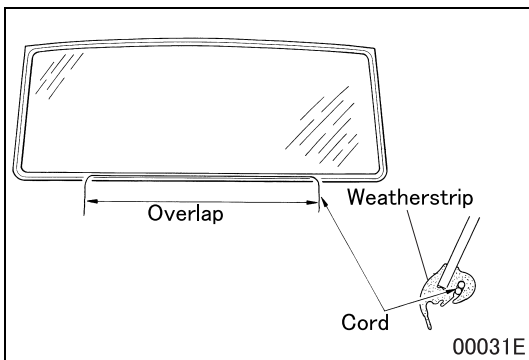

- Put a piece of strong cord in the cab flange fitting groove in the weatherstrip with its end portions overlapped.

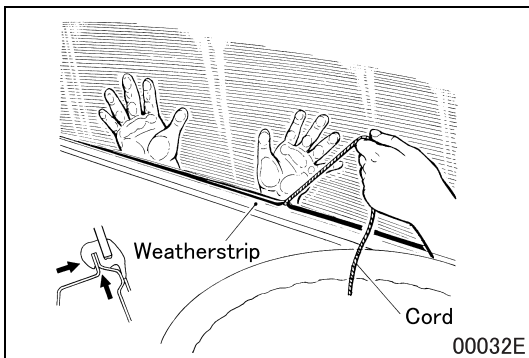

- With the glass strongly pushed from outside, pull out the cord by its ends from inside the cab to gradually fit the flange of the cab in the inner groove of the weatherstrip.

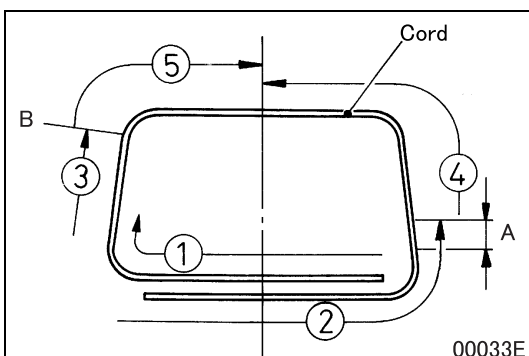

- Pull the cord in the numerical order of steps as shown. At the same time, while tapping with a rubber-headed mallet from outside the cab, settle the windshield glass in place in the weatherstrip.

A: Approx. 100 mm {3.9 in.} from the beginning of straight portion

B: Up to the end of straight portion

WINDSHIELD AND CAB REAR WINDOW

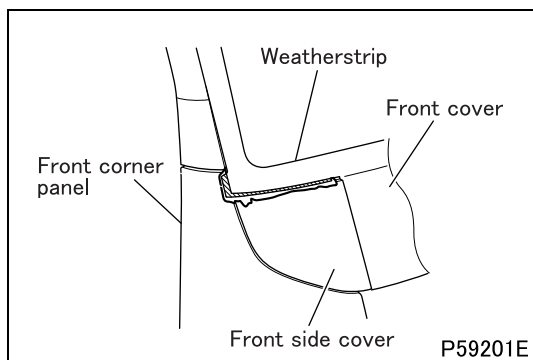

- To ensure watertightness, put the hatched part of the weatherstrip inside between the cab and the front cover, front side cover and front corner panel.